

ARCHOS™ MOBILE VIDEO RECORDER Gmini™ 500 SERIES



Video Player / Music Player & Recorder / Photo Wallet & Viewer / USB 2.0 Hard Drive



ARCHOS™ on the go

English Language User Manual

User Manual for ARCHOS™ Gmini™ 500 series

Version 1.1

Please visit our website to download the most recent manual and software for this product

Dear Customer,

ARCHOS™ thanks you for your choice of this exciting Gmini™ 500 product. The Gmini™ 500 is designed to be the companion to your home entertainment system. You can connect the Gmini™ 500 to your TV system to play back photos or videos as well as connect it to your PC to transfer over your favorite photos, videos, and music onto it. By connecting to a computer, you get the advantage of being able to download legal music and video content from the Internet. Since it is a PlaysForSure™ device, you have a wide choice of music and video content available on the Internet. For more information about the PlaysForSure™ program, see www.playsforsure.com.

This manual will explain, in detail, the functionality of your device. We have packed this product with many functions and capabilities. The better you know how to use it, the more enjoyment you will get from it. Remember, with the Gmini™ 500, you can...

- Play MPEG-4 SP & WMV video files* on the built-in screen, a television or video projector
- Listen to MP3, WMA, or WAV music files* or PlaysForSure™ downloaded music files
- Synchronize your Windows® Media Player music and video library to your Gmini™ 500
- View JPEG and BMP digital photos and create slide shows
- Copy Pictures directly from your digital camera via the built in host USB port
- Store .DOC, .PDF, or any type of data file – it's a portable hard drive too!

We wish you many years of enjoyment from your Gmini™ 500 product. Please do register your product at our website www.archos.com to ensure that you get have access to our help line and to be informed of technical support and free software updates for your product.

Wishing you the best Video, Music, and Photo experience,

The ARCHOS™ TEAM

**For full information on compatible file formats, see the technical specifications.*

Please take the time to read though this manual. There are many things that this device can do that you may not be aware of.

Table of contents

1	INTRO – Buttons and Connections	7
2	INTRO – First Time Usage	10
2.1	Charging the battery	10
2.2	Turning on the Gmini™ 500	10
2.3	Shutting off the Gmini™ 500 and Battery saving features	10
2.4	Changing the Interface Language	11
2.5	Foreign Character Sets	11
2.6	Caring for the Gmini™ 500	11
2.7	Hardware Reset	12
3	VIDEO – Playing Video Files	13
3.1	Video Playback Action Icons	14
3.2	Resume Function	15
4	VIDEO – Playing Video Files from the Internet	16
4.1	Protected Internet Video content	16
4.1	Non Protected Internet Video Content	16
5	VIDEO – Creating MPEG-4 Video Files with your Computer	18
5.1	Installing the PC Software	19
6	MUSIC – Playing Music Files	23
6.1	Button Control	24
6.2	Play Screen Icons	24
6.3	Browsing through your Music Library	26
6.4	Playing Through your Stereo System	27
6.5	Setting a Bookmark	27
6.6	The Resume Function	28
7	MUSIC – Putting Music onto your Gmini™ 500	29

7.1	Synchronizing Music from Windows Media® Player (WMP) to the Gmini™ 500	29
7.2	Comparison of Windows Media Player 10 to Windows Media Player 9	30
7.3	Transferring your CD collection to the Gmini™ 500	31
7.4	Installing Windows Media® Player 9 (WMP9)	31
7.5	Installing Windows Media® Player 10 (WMP10)	31
8	MUSIC – Playlists	32
8.1	Playing a Playlist	32
8.2	Creating a Playlist	32
8.3	Saving a Playlist	33
8.4	Adding songs to a Playlist while listening to Music	34
9	MUSIC – Recording Music	35
9.1	Cable connections for audio recording	35
9.2	Recording Procedure	36
9.3	Where is the Recording Saved?	38
9.4	Audio Editing	38
10	MUSIC – Using iTunes™ with your Gmini™ 500	40
11	PHOTO – Viewing Photos	41
11.1	Viewing Photos	41
11.2	Viewing a slideshow	42
11.3	Transferring photos to your Gmini™ 500	43
12	BROWSER – Using the Browser	45
12.1	Navigating the Directory Structure	46
12.2	File and Folder Operations	47
12.3	Using the Virtual Keyboard	50
13	Connecting/Disconnecting* the Gmini™ 500 to/from your PC	51
13.1	USB Connection Type ('Hard Drive' or 'Windows Device')	51
13.2	Connecting the Gmini™ 500	51
13.3	Disconnecting the Gmini™ 500 from your Computer	53
14	Connecting Devices to the USB Host Port	55

15	SETTINGS	56
15.1	Sound Settings	56
15.2	Play Mode Settings	57
15.3	Clock Settings	58
15.5	Appearance settings	60
15.6	Power Settings	60
15.7	System Settings	61
16	Updating the Gmini™ 500 Firmware Operating System (OS)	63
17	Replacing the battery	65
17.1	"Thin" version	65
17.2	Standard version	66
18	Technical Support	67
19	Troubleshooting	70
19.1	USB Connection issues	70
19.2	Charging and Power issues	71
19.3	Gmini™ 500 locks up (freezes operation) or Stops	71
19.4	File issues, corrupted data, formatting, and partitioning	71
20	Technical Specifications	74
21	Legal	76
22	Index	80

1 INTRO – Buttons and Connections



7

8

- a On indicator
- b Hard drive activity indicator (read/write)
- c Battery charger indicator (blinks when battery is charged)

- d Loud speaker

- e Move UP (also increases volume during media playback)
- f Move DOWN (also decreases volume during media playback)
- g Move LEFT (also plays previous song or fast reverse through song or video)
- h Move RIGHT (also plays next song or fast forward through song or video)
- i Accelerate UP – go up the list of items at high speed
- j Accelerate Down – go down the list of items at high speed

- k Play/Enter/On **o** – Hold for 3 seconds to switch on the device
- l Stop/Escape/Off **x** - Hold for 3 seconds to switch off the device

- m UP action button (move up on the list of action icons; in the Settings menus: move UP)
- n SELECT action button (select the highlighted action icon)
- o DOWN action button (move down on the list of action icons; in the Settings menus: move DOWN)

- a LCD/TV button – Hold down to switch between the LCD and an external TV display
- b USB Host port – to connect compatible USB devices
- c Microphone
- d USB 2.0 High speed device port (USB 1.1 compatible) to connect to your computer
- e Power Connector (Use only the supplied Archos power charger/adaptor)
- f Multi-connect jack* – for headphones, TV docking pod, FM Remote and AV in/out connections



* Optional accessories such as TV docking pod and FM Remote are available for purchase from the ARCHOS™ web site - www.archos.com.

2 INTRO – First Time Usage

2.1 Charging the battery

- Use only the included ARCHOS™ charger/adaptor.
- You can charge the internal battery of the Gmini™ 500 by plugging the included adapter/charger directly into the device, or you can charge it by plugging the adapter/charger into the optional TV docking pod and connecting your Gmini™ 500 to the Pod.
- Before using for the first time, charge the battery completely. The charge indicator (CHG) light will start to blink when the battery is charged.

2.2 Turning on the Gmini™ 500

- **Hold the PLAY/ON button **o** for 3 seconds.** The green “On” indicator light will turn on. Be patient, it will take a few seconds for the operating system to boot up.
- If the unit shuts off after holding the ON button for several seconds, plug in the ARCHOS™ adapter/charger to make sure the battery gets charged.

2.3 Shutting off the Gmini™ 500 and Battery saving features

To shut off the unit, press and hold the STOP/ESC/OFF button **x** for 3 seconds.

In the Power menu [**Display setup screen Power: Battery Operation**] there is a **Power Off** parameter. Thus, if your Gmini™ 500 is idle for a couple of minutes, it will shut itself off. This setting can be changed from one to nine minutes or to **never**.

In the Power menu [**Display setup screen Power: Battery Operation**] there is a **Backlight Off** parameter to save battery power (the lighting of the screen consumes a lot of the battery power). That is, if the Gmini™ 500 is not being used, the screen will shut off in order to save battery life. To turn the screen back on, just click once on any button. See the section **Power** in the **Settings** chapter for a complete explanation.



2.4 Changing the Interface Language

The Gmini™ 500 interface can be set to English (default), French, Spanish, German, or Russian.

- Using the UP action button, highlight the **Settings** icon (showing a wrench) and then click the center SELECT action button.
- Highlight the Display icon and click the PLAY/ENTER button.
- Highlight the **Language** parameter using the UP/DOWN buttons.
- Click the RIGHT or LEFT button to choose the desired language.
- The language displayed will change immediately.
- Click on the STOP/ESC button to return to the Setup page and again to return to the main menu screen.

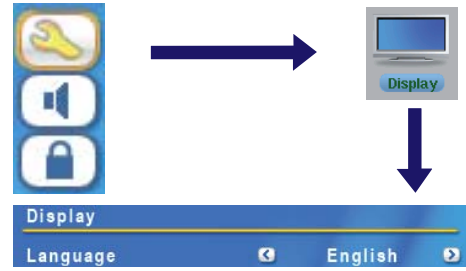

2.5 Foreign Character Sets

You have the option of displaying file names, folder names, and music tags in various character sets (ex: Korean, Japanese, Simplified Chinese, etc.). You can find the language files *CodePage_name.4FZ* in the font folder under **/Data/Asian Fonts** on the Gmini™ 500 hard drive or on the ARCHOS™ website under the heading Software. If, for example, you would like to have the Korean language display, then you would copy the file *CP949.4FZ* into the folder **/system** on the Gmini™ 500 and shut down and restart the Gmini™ 500. File names, folder names, and music tags written using the Microsoft® codepage for the language will now be displayed in that character set. Only one .4FZ can be used at a time, thus you should only put one .4FZ file into the **/system** folder. When an .4FZ language file is used, the interface language will be set to English.

2.6 Caring for the Gmini™ 500

The ARCHOS™ Video Gmini™ 500 is an electronic product that needs to be treated with more care than typical consumer electronic products.

- Do not subject it to shock.
- Do not subject it to heat. Keep it well ventilated.
- Keep the Gmini™ 500 away from water and excessively humid areas.

11

- Keep the Gmini™ 500 away from high electromagnetic fields.
- Keep any connected cords to the Gmini™ 500 neatly arranged. This light product could fall if a cord is accidentally pulled by a child.
- Do not open up the Gmini™ 500. There are no user serviceable parts inside. Opening will void your warranty.

2.7 Hardware Reset

In the event that your Gmini™ 500 freezes operation (due to electrostatic phenomena for example), you can reset the Gmini™ 500 by holding down on the STOP/ESC button **x** for 15 seconds. In normal operation, the STOP/ESC button **x** will shut down the Gmini™ 500 after being held down for 3 seconds.

3 VIDEO – Playing Video Files



Click on the **Video** icon in the main menu, highlight the desired video file, and then click on PLAY/GO . The thumbnail images on the right side will show you a frame from the highlighted video file (center) as well as a frame from the file above and the file below the highlighted one. By clicking on the Video icon in the main menu, you will enter into a 'video only' mode. Other playable file types, for example music files, that may be in this folder are only listed if you enter the folder via the Browser.

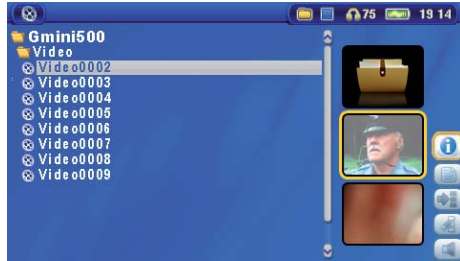

To watch your videos on a television, you must hold down the LCD/TV button for two seconds. The Gmini™ 500 screen will go black and the video will be sent out to your connected television. Switch your television to auxiliary video input (often found just below channel 1 – sometimes called L1 or L2). If you don't see a clear color image, you may have to set your Gmini™ 500 to your local television standard (NTSC-North America or PAL-Europe) in **Display (Setup action icon > Display Icon**.

Button controls while playing a video file

Vol +	Increase volume
Vol -	Decrease volume
Rew.	Fast Forward
FF	Fast forward
HSR	High speed reverse
HSA	High speed advance
O	Play/Pause
X	Stop

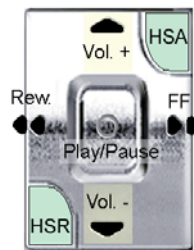

13

Video Browser Action Icons



Hide the Thumbnails



Reset thumbnails. The thumbnail images on the right side of the screen will be reset to their original default setting.

3.1 Video Playback Action Icons

While a video file is playing, click on the **Select** action button. The action icons on the right of the screen allow you to make video adjustments to your personal taste.

Play & Sound Settings



Use this setting if you would like to have the video files play one after the other, or just play one and stop. You can also adjust the sound settings and the amount of time the On Screen Display (OSD) information remains on the screen when you start a video file.

Built-in Speaker



Turn on or off the built-in loud speaker.

Slow Motion



Put the video into slow-motion view. You can cycle through the values Normal, $\frac{1}{2}$, $\frac{1}{4}$, and $\frac{1}{8}$ speed. The sound is muted when in slow motion. While in slow mode and paused, you can step image per image with the RIGHT button.

Set Screen Format



Video files come in various aspect ratios. That is, they can be TV sized (almost a square image), or in cinema size (much longer than high). To change the screen to your personal tastes, the following screen format options are available.

Auto Format	Default mode. Adjusts the video size to best adapt to the built-in screen or television.
Maximized Image	Enlarge the image to fill the screen (LCD or TV). Sides may get slightly cut in this mode.
Full Picture Format	The entire picture will always be seen on the television and the built-in screen. No cutting.

Set a Book mark



If you are watching a video and would like to place a bookmark in it in order to continue from this point at another time, you can use the Bookmark function. Highlight the icon and click on the **Select** action button. This will set a bookmark in the video file at the current position. You can only set one bookmark per file. When you look at the file in your browser, it will have a yellow check mark on its icon indicating that this file has a bookmark set within it. You can have a maximum of 16 files book-marked. Setting more bookmarks will then start to erase the oldest bookmarks. The next time you play this video file, you will be presented with three options:

Resume	Start playing from the book-marked position.
Ignore	Keep the bookmark but start playing from the very beginning.
Clear	Clear the bookmark from this file and start playing from the very beginning.

Save as Thumbnail



Save the current image on the screen as the video file's thumbnail in the Video browser view.

On Screen Display (OSD) off



Select this icon to shut off the On Screen Display (the status bar, action icons, and other overlaid informational graphics).

3.2 Resume Function

When you turn on your Gmini™ 500 you may notice that the icon which is highlighted on the main screen is not the **Video** icon but rather the **Resume** icon. This icon is highlighted when the Gmini™ 500 can resume the last played audio or video file.



15

4 VIDEO – Playing Video Files from the Internet

When using Windows Media® Player 10, you will have the advantage of being able to download protected video content from the Internet. When you see the PlaysForSure™ symbol on a web site for Windows® Portable Media Center (PMC)*, then these protected downloads will be playable on your Gmini™ 500.

4.1 Protected Internet Video content

If you check the PlaysForSure™ website (www.playsforsure.com) you will find web retailers who offer rental, subscription, or purchasable video content. Remember, web sites must carry the PlaysForSure™ symbol in order for their videos to play on the Gmini™ 500.

4.1 Non Protected Internet Video Content

The Gmini™ 500 plays .AVI files of MPEG-4 format. It can play such video files at a maximum size of 720 x 576 pixels (25 frames/second). It can also play .WMV files (WMV9 SP) up to a maximum size of 352 x 288**. The Gmini™ 500 will not directly play files of type .mov, .mpg, or .mpeg.

The number of encoding and compression schemes currently used to create video files is very extensive and seems to change on a weekly basis. There are so many standards and formats that it is very possible that the video file you download from the Internet will not play right away on your device. Due to certain "variations", even when video files are formatted in "MPEG-4" they may not play right away.

* MPEG-4: ISO standard by Moving Picture Experts Group ; AVI: audio/video file container by Microsoft . MPEG-4 SP with B-frames AVI up to 704x480@30f/s NTSC or 720x576@25f/s PAL.

** Microsoft WMV9 SP up to 352x288@30f/s and 800 kb/s ; supports WM DRM.

If you have some video files that do not play directly on your Gmini™ 500, they will have to be converted first. Windows Media® Player 10 (Available only for Windows XP) will convert your video file automatically when you sync the file that is on your PC to the Gmini™ 500. It will display a little message 'converting'.

You can also use the software **MPEG-4 Translator** included on the Gmini™ 500 hard drive to re-encode your video files into the proper MPEG-4 SP format that the Gmini™ 500 can play. See the chapter **Video – creating MPEG-4 video files with your computer** for more details.

5 VIDEO – Creating MPEG-4 Video Files with your Computer

How to create an MPEG-4 video file

Video files that come from your digital camcorder, sent to you via e-mail, or which are freely available on the Internet are encoded in many different ways. If not already in the proper MPEG-4 Simple Profile or WMV9 Simple Profile format, a transformation operation must be done in order that these video files can be played by the Gmini™ 500. This transformation process is called re-encoding.

There are basically two ways to do this: 1) Use the Synchronize button in Windows Media® Player 10 or 2) Use the PC tools which are available on the Gmini™ 500's hard drive. The first method is very simple and merely requires that you synchronize a video file in your Media Player library to your Gmini™ 500. You do not have much control in this converting process though and Windows Media® Player determines which video types it will and will not re-encode. The second method, though it requires some learning, will allow you to have much more control over the final quality of the re-encoded (converted) video file. It is described below. There are other tools available on the Internet, some free and some for sale, that can also convert your video files into the appropriate MPEG-4 SP video file format for the Gmini™ 500. See the web site www.mpegmobile.com for a list of a few of them.

PC Tools

The Gmini™ 500 is delivered with two Windows® based programs that allow you to create MPEG-4 Simple Profile .AVI video files. They are the MPEG-4 Translator and Virtual Dub™. The MPEG-4 Translator will call the Virtual Dub program and give it the correct parameters to encode your video from its original format, .avi or .mpeg (mpeg 1), and then encode it into an MPEG-4 SP .AVI file. The file will be scaled in order to be played back properly.

5.1 Installing the PC Software

If your video file is not an MPEG-4 Simple Profile .avi file of the proper size, you will need to re-encode it using the following utilities. For the Gmini™ 500, you will need to create an AVI file that is MPEG-4 Simple Profile with a resolution up to 720 x 576 (depending on frame rate) and a sound track that is stereo MP3 or WAV. In actuality, in all cases, a resolution beyond 640x480 does not add any advantage.

MPEG-4 codec (Compression/Decompression)

In order for MPEG4-Translator to compress the video in a file of the format MPEG-4 SP that the Gmini™ 500 can read, it requires an MPEG-4 codec to be installed on your computer. If you do not have the appropriate codec installed, MPEG-4 Translator will tell you on start up which codec it requires. You will be able to download it for free from the Internet.

Virtual Dub™

A utility for transcoding one video file into another. This is a general purpose transfer and cleanup utility which has many options allowing for even the most difficult video translations. It will prompt you to save it to C:\Program Files\VirtualDub. You should use this default directory location. Otherwise you will have to instruct the MPEG-4 Translator program where to find it. For more information on Virtual Dub™ see the website - <http://www.virtualdub.org>.

MPEG-4 Translator

This program, developed by Archos, is a "Front-end" for the Virtual Dub program. It has a simple interface which you use and it then tells Virtual Dub how to process the video file. It sets all the parameters for Virtual Dub specifically to create a video file in the right size and format to be read by the Gmini™ 500. When you run it for the first time, the MPEG-4 Translator will need to locate the Virtual Dub program. If you did not install Virtual Dub in the default location, you will have to show the program where Virtual Dub is. If you forget, Windows® will give you an error when you try to launch it.

19

20

MP3 Sound Codec

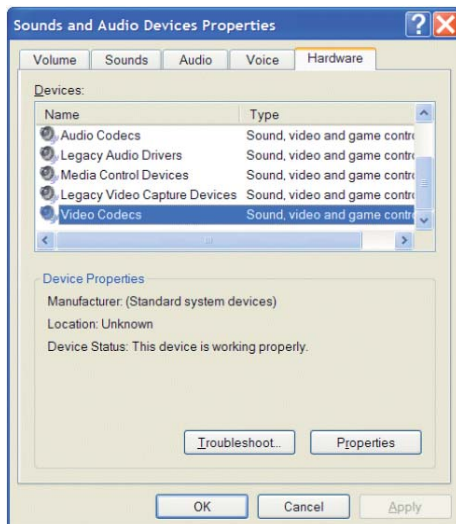

If MPEG-4 Translator detects a suitable MP3 codec on your PC, it will use it, and your video file sound track will be MP3. Otherwise, it will use the standard IMA ADPCM codec. There are MP3 encoders (usually packaged together as an encoder and decoder) available on the Web for you to download. If you choose to use the *LAME* codec, make sure that you have a version built with the ACM front-end. You can find other MP3 codecs on the web by using the search terms *ACM*, *MP3* and *CODEC* in your favorite web search engine. Once this MP3 codec is installed into your system, MPEG-4 Translator will be able to create final video files with MP3 sound, even if the source video file does not have an MP3 sound track.

If you are unsure what codecs (audio and/or video) have been installed on your computer, you can see the list by going to the following location.

For Windows XP, click on **Start > Settings > Control Panel > Sounds and Audio Devices Properties > Hardware**, choose Audio Codecs, then click on Properties. You will find a list here of all the audio codecs that are installed on your computer. Decoding of MPEG 2 video files is currently not supported by MPEG-4 Translator. These are usually .mpg or .mpeg format files, not the required AVI file. There are other tools found on the Internet (FlaskMPEG, Rippack, etc.) that may be downloaded in order to help you with these file types. A good starting place is the website www.mpegmobile.com.

5.2 Using MPEG-4 Translator

Here you see the image of the main MPEG-4 Translator program. When you first run the program, if the required codec has not been installed yet, you will be notified. You should download the codec and install it on your computer. If the Virtual Dub™ program has not been installed, you will also be notified, and you should install it. If you have placed the Virtual Dub™ program in a folder other than the installer default folder, it will ask you to locate the file.

20

Select Source & Destination Files

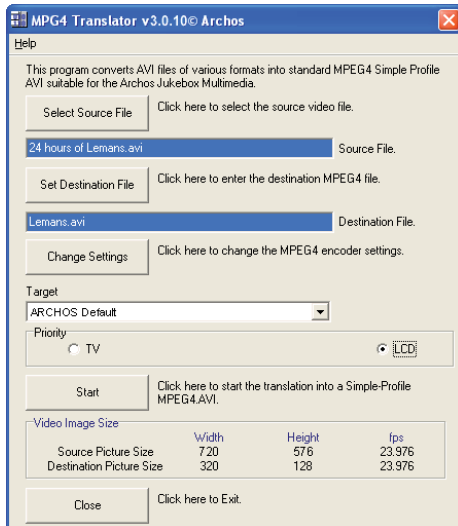

In this example, a source file **24 hours of Lemans.avi** has been selected as the source video. You can see on the bottom of the window its original characteristics (width 720, height 576, frame rate 24). Next, you must then tell the program where to place (Set Destination file) the newly recoded version of the file (don't worry, it will not erase the original). You should give it a new descriptive name. Make sure you add the .avi extension.

Change Settings



Next, you can change the parameters (Change Settings) of the encoder to adjust the level of quality of the final image. Like MP3 music, the higher the bit rate setting is made, the higher the quality of the music, or video in this case, that you will get. However, this will also take up more space on your hard drive. A setting of 900 kbps will give you a nice looking image for viewing on a television. For near DVD quality, you can set it up to 1200 kbps.

21

Target & Priority

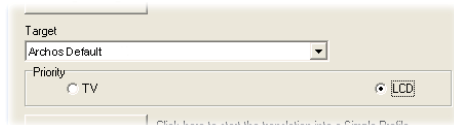

If the Gmini™ 500 device is not listed, select "ARCHOS Default". You will see a Priority box appear. This control is to allow you to select which feature of the video to be guarded. If for example you are re-encoding a video file that is 800x600 in resolution and 30 frames per second, this is beyond the maximum resolution that the Gmini™ 500 can play. Thus, the MPEG-4 Translator program will have to decrease the resolution. Choosing **LCD** optimizes the final video format for viewing on the built in LCD screen. Choosing the **TV** option will optimize the movie to keep the highest possible frame rate. You can see what the size and frame rate will be by looking at the **Video Image Size : Destination** parameters. When choosing **TV**, it is understood that the output will be optimized for a television, and not the built-in screen.

Start

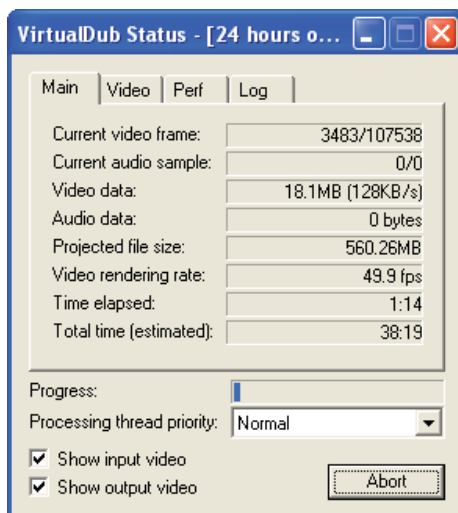

Click on Start and the program will call Virtual Dub™ to start processing the video. Depending on the power and speed of your computer, this could take real time (a 60 minute long video re-encoded in about 60 minutes) or much longer. As shown to the left, you will see the progress as it processes the video file. If the Start button is grayed out, it would be for one of two reasons. 1) The source file is not a true AVI file. Even if the file name ends with .avi, the internal file data determines if it is truly an AVI file. 2) The Virtual Dub program was not located when MPEG-4 Translator was started up. Close the program, restart it, and make sure you locate the Virtual Dub program.

6 MUSIC – Playing Music Files



When you click on the music icon in the main screen, you will be sent directly to the ARCLibrary. From here you can choose to either browse your music by the file system (Browse hard drive) or by music characteristics (Album, Artist, title, Genre, Year). Use the LEFT, RIGHT, UP, and DOWN buttons to locate one of the factory installed music samples and then click on PLAY. If you hear nothing at first, make sure you have adjusted the volume control on the headphone cord.



Display during music playback

1. Current Directory
2. Play Mode: One Directory
3. Status: Playing
4. Battery level
5. Volume (maximum:99)
6. Song title* or file name
7. Artist* or parent folder
8. Album* or current folder
9. Next track to be played
10. Relative location in the track
11. Elapsed, remaining, and total song time
12. Time of Day
13. Album picture*
14. File format and rec info
15. Volume level meters

*If the file contains these tag data



23

24

6.1 Button Control

- | | |
|--------|---|
| Vol + | Increase the Volume |
| HSA | High speed advance |
| FF | Click once: Play the next song in the folder or playlist.
Hold: Fast forward through the song. |
| Rew | Click once: Play the previous song in the folder or playlist (during first 10 seconds of song) otherwise go to the beginning of the song.
Hold: Fast reverse through the song. |
| HSR | High speed reverse |
| Vol. - | Decrease the Volume |
| o | Play/pause/resume |
| X | Stop Song |

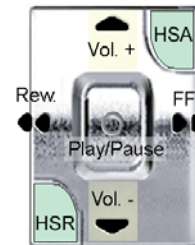

To lock the Gmini™ 500 buttons, select the **Lock** action icon on the main screen and press the Select button.



The Gmini™ 500 will display the "locked" icon in the top left corner of the screen. Press the Select button again to unlock the buttons. You can still use the UP and DOWN buttons to change the volume.



6.2 Play Screen Icons









Status

- Stopped
- Blinks while Playing a track
- Current track is paused
- Recording a track

Play Order

-  (no icon) Play once
-  Repeat playing
-  Shuffle (Random) track selection

Play Mode

-  Gmini™ 500 is currently playing from a Playlist
-  **Folder:** Play all tracks in the current directory
-  **All:** Play all tracks on Gmini™ 500
-  **Single:** Play a single track then stop
-  **Queue:** User can queue the next track to be played *
-  **Scan:** Plays first 10 – 90 seconds of each track*

* See the PlayMode section in the Settings chapter of this manual for details.

6.3 Browsing through your Music Library



The ARCLibrary is your Gmini™ 500's music library. It is a system for indexing your music by album, artist, song title, etc. When you synchronize music files from your PC using Windows Media® Player to the Gmini™ 500, the ARCLibrary will get updated to include the new songs you have added. As shown in this screen capture, you can select your music by Artist, Album, Song Title, Genre, or Year.

All music files that you purchase have internal 'tags' which identify the artist, the album, and the song title. If your music files do not have internal tags (ex: WAV file format or untagged WMA or MP3 files) then the ARCLibrary will put them under the category (**Unknown**). Audio files created with the Gmini™ 500 from analog sources are indexed as Artist = (ARCHOS) and Album = (**Audio Recordings**).

You can reach the PlayMode settings screen from the **Setup** action icon > **PlayMode**. The play mode determines how your music is played (just the current folder of music, all music, one file, etc.). See **Playmode** in the section **Settings** for a description of how each one works.



6.4 Playing Through your Stereo System

To play your music through your stereo system, you can connect your AV cable as shown.



Playing through a Stereo system with an AV Cable

6.5 Setting a Bookmark

If you are listening to a song, or perhaps a long recording, and would like to place a bookmark in it in order to pick up from this point at another time, you can use the Bookmark function. Simply select the **Set Bookmark** action icon. This will set a bookmark in the audio file at the current position. You can only set one bookmark per file.



When you look at the file in your browser, it will have a yellow check mark on its icon indicating that this file has a bookmark set within it. You can have a maximum of 16 files bookmarked. Setting more bookmarks will then start to erase the oldest bookmarks. The next time you play an audio file which contains a bookmark, you will be presented with three options:

- Resume:** Start playing from the bookmarked position.
- Ignore:** Keep the bookmark but start playing from the very beginning.
- Clear:** Clear the bookmark from this file and start playing from the very beginning.

27

6.6 The Resume Function



When you turn on your Gmini™ 500 you may notice that the icon which is highlighted on the main screen is not the Browser but rather the Resume icon. This icon is highlighted when the Gmini™ 500 can resume the last played audio or video file.

7 MUSIC – Putting Music onto your Gmini™ 500



Your Archos™ product is a certified PlaysForSure™ digital device which means that wherever you find music for sale on the Internet with this symbol, you can be certain that it will 'Play for sure' on your Gmini™ 500*.

The Gmini™ 500 is designed to work seamlessly with Windows Media® Player (WMP) versions 9 and 10. The Windows Media® Player software is used to download digital media content from the Internet to your computer and organize it. You will also use it to synchronize (copy) the contents of your Windows Media® Player media library to your Archos™ device. See the comparison chart below for an explanation of the different features available when running Windows Media Player 9 and 10 or check out the web site www.playsforsure.com.

*Subscription services require you to be running Windows Media® Player 10.

7.1 Synchronizing Music from Windows Media® Player (WMP) to the Gmini™ 500



The Synchronize button in Windows Media® Player (WMP) is a one way 'sync' button. That is, it will add music, video, and photo files to your Gmini™ 500 so that you have the same digital media on your Gmini™ 500 as you have in your Windows Media® Player media library. Of course, you can choose to sync only certain songs, videos, or photos, or sync your entire library. On WMP10, you can click the button

Set up Sync in the **Sync** tab and then check the box labeled **Synchronize Device Automatically**. This is the auto-sync advantage of WMP10. If this box is checked, then each time you connect your Gmini™ 500 to your PC, Windows Media® Player will automatically start up and check to see if there are any new music, videos, or photos in your media library, and if so, will then copy them to your Gmini™ 500. You also have the possibility to decide what types of media automatically sync when you connect your Gmini™ 500. For example, you may only want music files to be synchronized. On the other hand, with Windows Media® Player 9, you have to tell it what you want to sync, WMP9 cannot synchronize automatically when you connect your Gmini™ 500 to your computer.



Note for WMP10 users: Files added to your Gmini™ 500 from another computer or files which are recorded from an analog source cannot be added to the Windows Media® Player Library when you connect your Gmini™ 500 to the computer. Songs which have been added, will however, be listed in the device's ARCLibrary.

7.2 Comparison of Windows Media Player 10 to Windows Media Player 9

Windows® Media Player 10 is only available for Windows® XP (service Pack 1) and newer operating systems. It is worth your while to upgrade to Windows® XP (home or professional) and to Windows® Media Player 10. The list below shows the advantages.

Functionality

Auto-synchronize the WMP library to ARCHOS™ Gmini™ 500 on connecting to PC

Can synchronize subscription music ('to go' services) to your Gmini™ 500

Carefree USB disconnection (no special green arrow unmount procedure)

Will convert video files** to play on your Gmini™ 500 if not in correct format

Supports protected Internet video downloads

PlaysForSure™ audio content



WMP9

no*

no

no

no

no

yes (download)



WMP10

yes

yes

yes

yes

yes

yes



* Must use WMP9 manual sync function to copy purchased music to the Gmini™ 500.

**Microsoft reserves the right to limit which video file formats it will convert with WMP10

7.3 Transferring your CD collection to the Gmini™ 500



The process of transferring music from a CD into music files for your Gmini™ 500 is known as 'ripping'. It is actually a re-encoding process, taking the CDA (CD Audio) format and converting it to WMA or MP3 format which the Gmini™ 500 can read. There are many music ripping programs on the market, but ARCHOS™ recommends that you use Windows Media® Player to do it. In fact, when you place a music CD in your computer, Windows® will ask you if you would like to rip it. Depending on the power of your computer, to rip a 60 minute CD, it will take anywhere from 10 minutes to 60 minutes. Once this is done, the album will become part of your music library. Connect your Gmini™ 500 to your computer with the supplied USB cable. Now, you go to the Sync tab and tell Windows Media® Player to synchronize that album to your Gmini™ 500. It will then transfer that album to your Gmini™ 500.

Note: Some music CDs have a special copy protection system that will not allow Windows Media® Player to make music files from them.

7.4 Installing Windows Media® Player 9 (WMP9)

If you have Windows® ME or Windows® 2000, you should use Windows Media® Player 9. You can visit the Microsoft® Website to download the very latest version, or install the version found on the Gmini™ 500 itself in the folder /Data/PC Installation.

7.5 Installing Windows Media® Player 10 (WMP10)

You must be running Windows® XP (Service Pack 1 or higher) in order to install Windows Media® Player 10. Please visit the Microsoft® Website www.playsforsure.com to download and install the very latest version.

8 MUSIC – Playlists

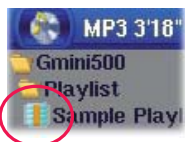

A Playlist is a list of songs that the Gmini™ 500 will automatically play one after the other. The Gmini™ 500 can load one Playlist at a time into its internal memory. You can create new Playlists, add or delete songs from a Playlist, or Save a Playlist to be used another time. There is no limit to the number of Playlists you can save on the Gmini™ 500 hard drive. Playlists are indicated by a special list icon (circled icon to the left).

8.1 Playing a Playlist



To play a Playlist, you simply scroll to the Playlist, such as 'Sample Playlist' shown to the left, and click on PLAY . The list of songs will be loaded into the internal memory of the Gmini™ 500 and then be displayed in a separate panel.

Click on PLAY and the songs will be played in the order shown. To shuffle the music entries in a random order, you can click on the **Manage Playlist** action icon, then choose **Shuffle**. If you delete a Playlist from your Gmini™ 500, you are only deleting the list and not the music itself.

8.2 Creating a Playlist

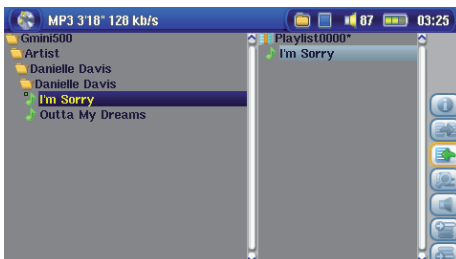

To create a Playlist, select the **Open Playlist panel** action icon while you are in the Music browser. A second panel will open on the right side to display the Playlist contents. You can now start adding songs to the current Playlist. In the left panel, locate the songs you would like to add to your Playlist. Once the song is highlighted, click on the RIGHT or ENTER button or select the **Add to Playlist** action icon to add it to the Playlist. The song will be added to the Playlist and a small mark next to the music icon will be made to indicate that it is in the Playlist. Continue searching and adding songs in this manner until you are satisfied. You can select the **Add** or **Insert** action buttons

when highlighting a folder, artist, or album. All the contents of the folder, artist, or album will be added (that is, appended) or inserted before the selected song in the current Playlist.

You can jump back and forth between the browser and the Playlist by selecting the **Focus** buttons. A Playlist can have a maximum of 5000 songs. We recommend that you save your Playlists.



8.3 Saving a Playlist



It is recommended that each time you create a Playlist, you save it to a separate folder called **Playlists**. These lists take very little space on your hard drive and if well named, give you easy access to your favorite songs. Go to the Playlist by selecting **Music** from the main menu and then select the **Open Playlist panel** action icon. You will then see the list of songs in the current Playlist. Use the action button to focus on the right panel, then select the **Manage Playlists** action icon, and select **Save**. **ATTENTION:** Make sure that your left panel is the **Playlists** folder because the open panel on the left is the location the Gmini™ 500 will be saving your Playlist to.

Save	Saves the current playlist to Playlists or the folder open in the left panel. The * after the Playlist name indicates that this playlist has not been saved.
Close	Clears the Playlist and closes the Playlist panel.
Rename	Renames the current playlist.
Clear	Clears the contents of the current playlist.
Shuffle	Randomly shuffles the order of the songs in the current playlist.

The following Playlist action icons are also available

Icon: Remove Track	Will delete the highlighted song from the Playlist. It will not delete the actual song itself from your hard drive, just from the current Playlist.
Icon: Move track	Allows you to change the place in the list of the highlighted song. Click on Move and then click on UP or DOWN to move the song up or down the list. Click OK when finished.

Important: Once you save a Playlist it is important that you do not move or rename the actual music files since the Playlist searches in the original file location. If you need to move your music files to a different folder, you'll have to recreate your Playlist.

8.4 Adding songs to a Playlist while listening to Music

This can only be done if you have entered your **Music** folder via the Music icon and not by the general browser. To add the song you are listening to or any other song to the current Playlist, do the following:

- While playing a song, choose the action icon **Playlist Editor**. A new window will open with two panels, the hard drive contents on the left, and the Playlist on the right.
- Select the **Focus** on the left panel action icon to go to the hard drive browser panel.
- Select the song or folder of songs to add, then click PLAY or the action icon **Add to Playlist**.
- Click ESC to return to the playing screen. Remember to save your changes before closing the Playlist.

9 MUSIC – Recording Music

With the Gmini™ 500 series, you do not need a computer to create digital music files. It is capable of recording from any standard analog line source (ex: HiFi system, Boombox, CD Player, etc) into a standard Windows® .WAV format, either PCM (uncompressed) or ADPCM (compressed).

9.1 Cable connections for audio recording

Plug the AV cable into the **AV In** side of the adapter, and then plug the adapter into the Gmini™ 500.

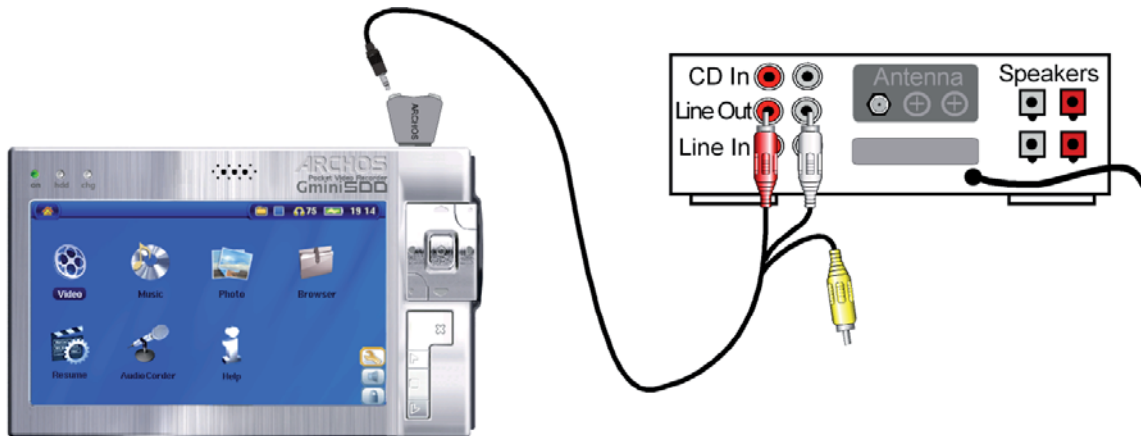

35

36

9.2 Recording Procedure

Before the actual audio recording begins, there is a pre-recording screen which will allow you to adjust your recording settings.

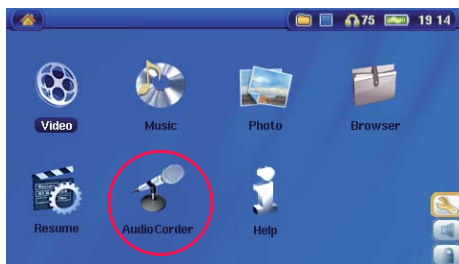

1. On the main screen, select **AudioCorder** then click on ENTER.

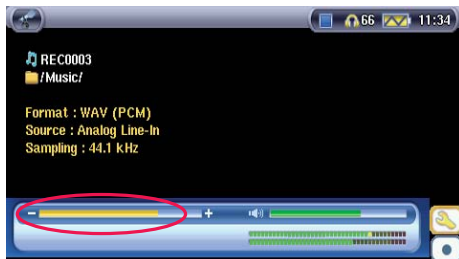

2. In the pre-recording screen, adjust the recording level* by clicking on the LEFT and RIGHT buttons. Click on the record action icon (or Enter button) to start recording. Attention, the first time recording you should adjust your **Settings**.

* You should try some test recordings before deciding on which recording level gives the best sound quality. Don't be tricked by the volume of the headphones which can be adjusted independently with the UP and DOWN buttons.

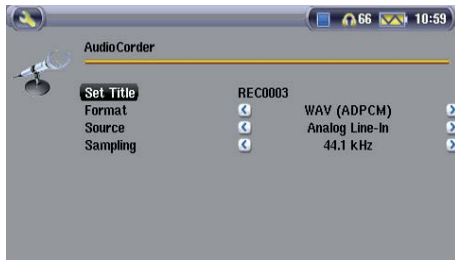

3. Click on the **Settings** action icon to reveal the recording parameters screen as shown.



4. Once you have clicked on the **Record** action icon (or Enter button), you can pause the recording by clicking the Pause action icon (or Enter button) and then stop the recording by clicking on the STOP button.

You can record from any line-level audio source to the Gmini™ 500. Be careful that the source audio is supplying a line level and not an amplified signal (turning down the volume on the player will work if you are using the headphone out signal of your audio device). A signal that is amplified too much will make for a terribly distorted recording.

Microphone

The built-in microphone is located on the top of the Gmini™ 500. Make sure that you have selected **Microphone** as the input source in the pre-recording Settings screen. The microphone level is preset.

37

Incremental Recording



While recording, you will notice the incremental recording action icon. This allows you to create incremental recordings. This means that the current recording stops and a new recording instantly begins. The next recording has an additional number appended to its name. Thus if you create multiple incremental recordings, you might, for example, have file names of REC0000_01, REC0000_02, etc.

This is good for recording old cassettes and old vinyl records. You can click on this icon during the blank space between each song. That way, each song of the vinyl disk or audio cassette will be one single music file.

9.3 Where is the Recording Saved?

The default location for audio recordings is the folder called **Music**. This can be changed though. For example, you click on the Music icon in the main menu and then you choose **Browse Hard Drive**. Notice that there is the **Launch Audiocorder** action icon. Each time you use this button to start the Audiocorder application instead of the AudioCorder button on the main menu, you set the recording default location to the current folder. For example, let's say you have a folder called */Music/Vinyls/Soul*. If you go to this folder and then make a recording using the action icon, you will set the default record location to this folder. Now, all your recordings you make with the Audiocorder icon will be saved in the folder */Music/Vinyls/Soul*.

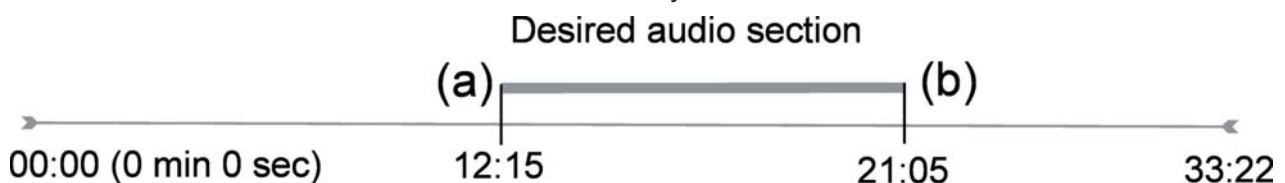

9.4 Audio Editing

Audio files (only recordings that were made from the AudioCorder icon) can be modified by deleting the sections you do not wish included. If you would like to edit an audio recording, you have the possibility to cut the file down to the specific part you want to keep. In the example below, you have recorded a lecture of 33 minutes and 22 seconds in length. You would like to cut out and save just one particular important section from 12 minutes and 15 seconds to 21 minutes and 5 seconds. The diagram below illustrates the situation.

To keep just this section (cropping it), you will:

- Locate this file via **Browse hard drive** in the Music application.
- From the action icons, select the **File Management** action icon and then select **Edit**.
- In the edit mode, set the **Cut In point** (12:15 in our example). This will remove the part of the file BEFORE the desired segment.
- Now set a **Cut Out point** (21:05 in our example. Please note: As you have cut part of the file, this position will actually be earlier in the file now).
- Validate and Save the edit. The file will be saved with the word "edit" appended to the file name in the same folder as the original.
- If you do not want to save your modifications, click the STOP/ESC button and select OK.

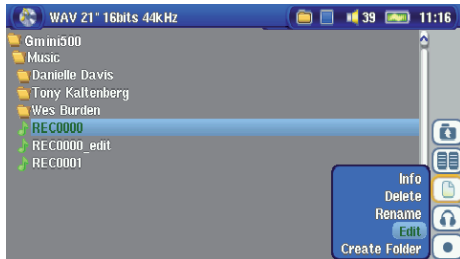

Highlight the file to edit and select the **File Management** action icon. Choose **Edit**. Only files which have been created with the Gmini™ 500 recording function will show **Edit** in the file menu. Files created from CDs or downloaded cannot be edited. Once you enter the edit mode, the audio file will play in a continuous loop so that you will be able to hear the changes to the edit as you make them.



Use the fast-reverse and fast-forward buttons (LEFT/RIGHT buttons) to locate the points you want the new file to start and end. These are the **Cut In** and **Cut Out** points. Once you have set these points, you can save the edit. In this example, a new file **REC0001_Edit** will be made. Your original file is left untouched. You will notice that your Cut In and Cut Out times are marked just below the file name.

39

10 MUSIC – Using iTunes™ with your Gmini™ 500

The easiest way to transfer music files between a Macintosh® computer and your Gmini™ 500 is to use the Macintosh Finder™ to drag and drop the files to and from your Macintosh®. However, for Macintosh® users who do want to use the Gmini™ 500 with iTunes®, ARCHOS™ has developed a special i-Tunes® plug-in. You will find it in the folder **/Data/i-Tunes Plug-in** on the Gmini™ 500 hard drive or at the ARCHOS™ website. In this folder you will find a plug-in for Mac OS 9.x and another folder for Mac OS 10.x. You will also find a JPEG image illustrating where you need to copy the plug-in to. Once this is done, iTunes™ will recognize the Gmini™ 500 as a 'Device'.

Attention

Your Gmini™ 500 needs to be set to "Hard drive" mode (see the section **System Settings** in the **Settings** chapter or the chapter **Connecting/Disconnecting the Gmini™ 500 to/from your PC** on how to do this.)

Please keep in mind the following:

- 1) Music purchased at Apple's on-line music store are copy protected with a proprietary encryption system. The ARCHOS™ device will not be able to play this purchased music or files in ACC format which you might have created. It will happily play MP3 format files without problem.
- 2) When you create your Playlists with iTunes® (you can only create Playlists from songs that have been copied to your Gmini™ 500), your Macintosh® will save these Playlists to the root directory of your Gmini™ 500. It will not save them to the Gmini™ 500 Playlists directory. It would be best to use the Gmini™ 500 itself to make Playlists and then save these Playlists in your Playlists folder. (See section **Creating a Playlist** in chapter **Music –Playlists**)
- 3) When you drag and drop MP3 files from your iTunes® library to your Gmini™ 500, the i-Tunes® program will look at the ID3 tag information of the MP3 file, and create a folder on the root of your Gmini™ 500 using the name of the Artist as the folder name. Then it will take the Album name ID3 tag, and create a subfolder with that album as its name. Finally, it will take the MP3 song itself and place it into that album subfolder. Thus, although it is a clean structure of artists and albums, i-Tunes® does not follow the Gmini™ 500 convention of placing the music into the **Music** folder first.

11 PHOTO – Viewing Photos



The Gmini™ 500 series support the viewing of JPEG (.jpg) and Bitmap (.bmp) image formats. Progressive JPEG images or certain camera formats such as NEF or RAW are not supported. The Gmini™ 500 will resize the image to fit on the built-in screen or on a television screen if you choose the television output. When you are in the Photo mode, it means that only files of type JPEG or BMP will be visible in the directory. Other file types will not be visible. The three images on the right are thumbnail sized pictures of the highlighted file (center) and the picture just before and just after the highlighted file. Select the Photo icon, then click Enter **o** in order to go to the Photo directory.

11.1 Viewing Photos



When you click Enter **o** on a highlighted image file, the Gmini™ 500 will display the image in full screen mode. Displayed as a full screen image, you can rotate it, magnify it, or set it as the Gmini™ 500 screen background with the **Save as Wallpaper** function in the **File Management** action icon.



1 x 1 image



2 x 2 images
(Zoom out 1x)



3 x 3 images
(Zoom out 2x)

41

42



Rotate picture 90° left

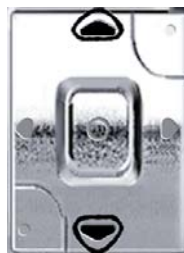

View previous/next photo



Rotate picture 90° right

- Move up the action icon menu to select a picture option.
- Select the **Zoom in/out** action icon to change the number of photos in the carousel view.

Magnifying Photos

Once the picture is displayed in full screen, selecting the Zoom in action icon will magnify the image up to two levels. Each successive click will magnify the picture one more level. You can use your direction buttons to move the picture around in order to see the desired magnified area. The small + signs on the bottom left of the screen indicate the level of magnification, either + or ++. Click on STOP/ESC to go back to an unmagnified view.

11.2 Viewing a slideshow

By clicking on the action icon **Play a Slideshow**, the Gmini™ 500 will present each picture in the current folder for a set amount of time and then go on to the next picture. You can set the amount of time that each picture stays on the screen under the action icon **Photo Browser Settings > Picture Pause**. This parameter is the number of seconds each picture displays on the screen.

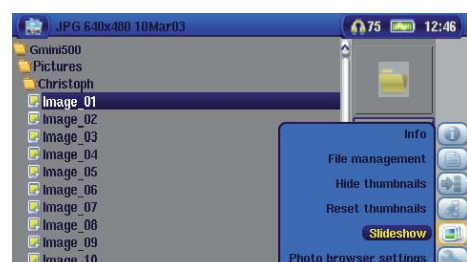

42

11.3 Transferring photos to your Gmini™ 500

The Gmini™ 500 is equipped with a USB host port. This port, along with the USB Host adapter cable will allow you to connect USB Mass Storage Class (MSC) devices to your Gmini™ 500 and transfer files from that device to your Gmini™ 500. Many cameras produced today are MSC type devices. Thus you can often plug your camera directly into the Gmini™ 500's USB Host port and copy your photos with the ARCHOS™ browser. If you do not have an MSC type camera, you can use a USB card reader and plug this into Gmini™ 500's USB host port (via the USB host adapter cable). Finally if neither of these solutions is available to you, you can always copy the photos to your computer and then copy them from your computer to the connected Gmini™ 500 (via USB 2).

3 methods to copy photos to your Gmini™ 500

- 1) Connect your Mass Storage Class camera to USB Host port (via USB host adapter cable).
- 2) Use a stand alone USB card reader with the USB host adapter cable.
- 3) Copy photos to your computer and then copy (or Sync with Windows Media® Player 10) to the Gmini™ 500 (via USB 2).



Method 1

Once you plug an MSC type device into the USB host port (via the host adapter cable), the browser's left panel will show the contents of your external USB device, and the right panel will show the contents of your Gmini™ 500's hard drive. Navigate to the panel which contains your photos (in this example */DCIM/113CANON*). Move to the right panel (action) and navigate to the folder you would like to save your photos to (you can create a new folder if you need to by selecting the corresponding action icon). See the screen images on the next page.

43



Photos from camera are shown on the left, and your Gmini™ 500 hard drive on the right. By using the **Select right pane** action icon, move to the right pane and choose the destination folder.



Now return to the left pane and choose the **Copy all files** action icon. Your files will be copied to your Gmini™, into the folder in the right pane. You can now unplug the camera from the Gmini™ 500.

12 BROWSER – Using the Browser



The browser is used to navigate the file system on the Gmini™ 500. The file system is FAT32, the same type of file system that is found on Windows® based computers. That is, it is a hierarchical system which includes folders and subfolders. Because you will be putting hundreds of files on your Gmini™ 500, it is **STRONGLY ADVISED** that you keep a neat and orderly file structure. Otherwise, you will be spending time searching for files and not listening or watching them. ARCHOS™ recommends that you keep the factory created folders: Data, Music, Playlists, Video, and Pictures.



The folders **Music**, **Pictures**, and **Video** are special folders in that the icons on the main screen lead to these folders and then places you directly in that folder. If these folders are deleted or renamed, you will be taken to the root level (highest level) of the directory hierarchy.

12.1 Navigating the Directory Structure

To navigate the directory structure you will use:



ENTER: Open the highlighted folder (directory) or Play the highlighted file.

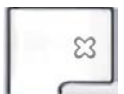

ESC/STOP **x**: Go back to the main menu.



Move the cursor up and down to the previous or next file or folder.



RIGHT: Open the currently highlighted folder.

LEFT: Go back up one level in the folder hierarchy. Example: Go from folder Gmini500/Music/Wes Burden/ to Gmini500/Music.



12.2 File and Folder Operations

Depending on where you are in the folder system, you will have the option to manipulate files and folders. From the main menu, click on Browser. Files that the Gmini™ 500 cannot play will be preceded by the unknown file type icon.

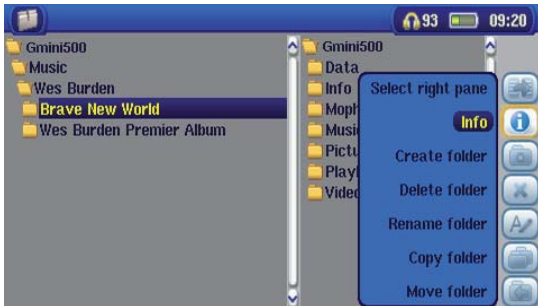

Folder Operations

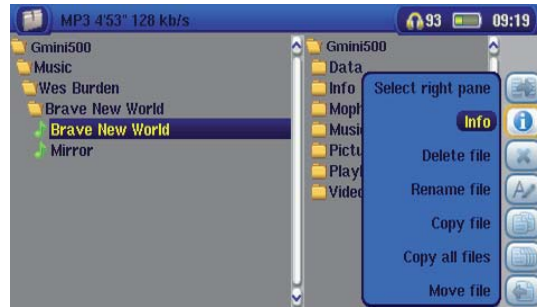

File Operations

Info	Show file information such as song length, video length, photo size, number of kilobytes used of hard drive space, date file was made, etc.
Create	Create a new folder inside the current folder.
Delete	Delete the file permanently from the Gmini™ 500. (Before it is deleted, the Gmini™ 500 will ask “Delete file: xxxxx ?”. Use the action buttons to reply Yes or No. For folder, it will delete the entire contents of the folder. It will ask “Delete folder: xxxxx and all files therein?” Use the action buttons to reply Yes or No.
Rename	Change the name of the file or folder to something new. You will be sent to the virtual keyboard (see section Virtual Keyboard in the Browser chapter) to enter the new file or folder name.
Create	Create a new folder in the current level of the directory. You will be sent to the virtual keyboard (see section Virtual Keyboard in the Browser chapter) to enter the new folder name.

47

Copy/Copy all files	Make a copy of the selected folder or file(s) and save it to the other pane.
Move	Move the selected folder or file to the other pane. The folder will be deleted from its current location.

Copying and Moving Files and Folders

By using the unique ARCHOS™ double browser system, you can copy or move files from one location in the file structure to another (1000 files per folder maximum). The double browser can be used in:

Photo View	The left panel is the connected USB device (ex: digital camera or hard drive) and the right panel the Gmini™ 500 hard drive contents.
Music View	The left browser is the Gmini™ 500 hard drive contents and right browser the music Playlist.
Browser View	Two panels to browse two different parts of the Gmini™ 500 hard drive.



In the Browser mode, you can jump between the two panels using the **Focus on the left/right panel** action icon. Where the cursor is highlighting a file or folder, that panel is the source for the copy. The destination folder will be the other panel. For example, we want to copy the file **Project info.doc** from the **Gmini™ 500/Data/Files from Work** folder to the **Gmini™ 500/Data/Completed projects** folder. We must start from the main screen Browser mode.



- 1) Locate and highlight the file to be copied. Using the action buttons, move to the right pane.

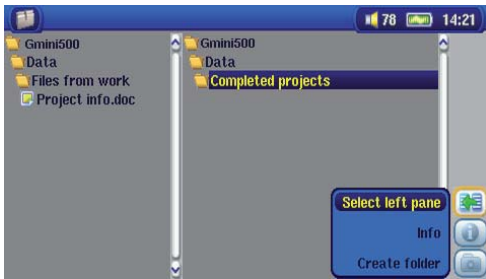

2) In the right pane, locate the destination folder. Then move back to the left pane.

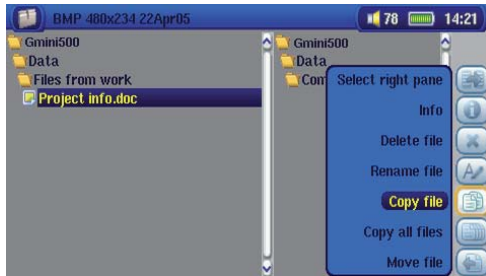

3) Highlight the file to be copied and select the **Copy file** action icon.

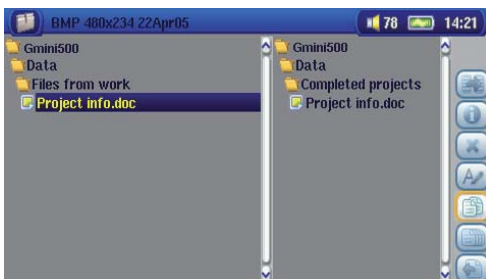

4) The selected file will now be copied into the destination folder.

Please note: You can only copy or move files from one folder to another and not within the same folder. If you select the same folder in both panes, these options are therefore not available.

49

12.3 Using the Virtual Keyboard

It is recommended that you create folders and rename files or folders from your computer when it is connected to the Gmini™ 500. The computer keyboard is much easier to use. However, at times when you are not near your computer and need to enter text directly with the Gmini™ 500 (ex: renaming a file or creating a new folder). For this, the virtual keyboard screen will appear.

The new text that you are typing

Cursor

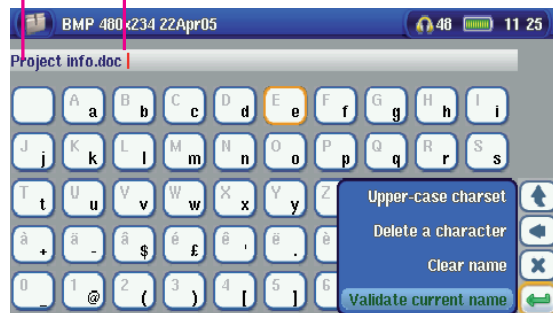

Press ENTER to enter the highlighted key/letter.

Change keyboard between upper case and lower case

Backspace button

Clear the entered text

Confirmation to use the entered text.

Hold down on the LEFT or RIGHT buttons to move the cursor within the entry line.

13 Connecting/Disconnecting* the Gmini™ 500 to/from your PC

13.1 USB Connection Type ('Hard Drive' or 'Windows Device')

Your device comes configured as a Windows® Device and will be immediately recognized by your computer if you are running Windows® XP (with Service Pack 1 minimum) and Windows Media® Player 10. If you have another version of Windows®, not sure what version of Windows® XP you have, or if you are using a Macintosh®, then you will need to change the USB (Universal Serial Bus) Port setting on the Gmini™ 500. You will do this by going to the **Settings** action icon and then to **System** and **USB Port** and change it to '**Hard Drive**'.

13.2 Connecting the Gmini™ 500

Connection order: See the sections below for your particular computer's operating system.

- 1) Connect the power adapter to the Gmini™ 500.
- 2) With your computer running, plug the USB cable into your computer.
- 3) With the Gmini™ 500 off, plug in the other end of the USB cable to the Gmini™ 500 USB Device port.
- 4) Turn on the Gmini™ 500. (If your computer asks to install a new driver for the new hardware, then you must unplug it and change the USB Port to Hard Drive.)

** Note that when the Gmini™ 500 is connected to a computer, it will use more energy than usual. Your battery power will be consumed at a higher rate than normal. It is normal that the Gmini™ 500 will get hot. If the Gmini™ 500 loses power while connected to your computer you could damage your directory structure and/or loose data. Thus, you should always use the AC adapter when connected to your computer. Be careful to understand the disconnection procedure also since disconnecting incorrectly can lead to data loss or computer/Gmini™ 500 freeze up. The Gmini™ 500 is not compatible with Windows® NT, Windows® 95, or Windows® 98. While connected to your computer, the Gmini™ 500 buttons are blocked and are no longer functional.*

Windows® XP

Please verify that you have Windows® XP and it is updated it to at least, Service Pack 1.** You must also have Windows Media® Player 10 (WMP10) installed on your computer. This way, you can take advantage of connecting it as a '**Windows Device**'. Connect it to your PC as enumerated above and you can then see the Gmini™ 500 in Windows® Explorer and WMP10. Without Windows® XP Service Pack 1 (a free update) or Windows Media Player® 10, you cannot use it as a Windows® recognized 'Device' and will have to follow the instructions for Windows® ME & 2000 below.

**** Right-click on 'My Computer' select 'Properties', and then look in the tab labeled 'General'. It should say "Service Pack 1" or higher.**

Windows® ME and 2000



Attention: Before connecting the Gmini™ 500 to your computer with the USB cable, go to the setup action icon and then to System and USB Port and change it to 'Hard Drive'.

When connected to your computer, the Gmini™ 500 will be recognized as an external Hard Drive and display automatically within a few seconds of being connected. You will see a new drive letter, such as E: in My Computer called Gmini™ 500. You can now use the hard drive called Gmini™ 500 like any other external hard drive. Simply access it using Windows® Explorer to drag and drop files to and from the Gmini™ 500's hard drive.

Macintosh™ OS X



If you have OS X, you must update to version 10.2.4 or newer. You must also change the Gmini™ 500's USB Port setting to '**Hard Drive**'. From the main menu, go to the **Settings** action icon and then to **System** and **USB Port** and change it to '**Hard Drive**'.

You will now simply plug the Gmini™ 500 into your Macintosh® as enumerated above, and within a few seconds, the Gmini™ 500 will be recognized as a mass storage device (Hard Drive) and mount on the desktop. You can now use the hard drive called Gmini™ 500 like any other external hard drive.

13.3 Disconnecting the Gmini™ 500 from your Computer

Windows Device Mode



If the Gmini™ 500 is connected to your computer as a Windows Device, verify that no data is being transferred between your Gmini™ 500 and your computer (the HDD light on your Gmini™ 500 is not flickering). You can now safely unplug the USB cable from your Gmini™ 500 and/or computer.

Hard Drive Mode



Gmini500

If the Gmini™ 500 is connected to your computer as a hard drive, **DO NOT SIMPLY PULL OUT THE USB CABLE AT ANY TIME!**

WARNING: You must properly remove (unmount) your Gmini™ 500 from the computer before disconnecting the USB cable to avoid loss of data or freezing the computer and/or the Gmini™ 500.

Hard Drive Mode & Windows®

To safely disconnect the Gmini™ 500 hard drive, click on the system tray remove icon (green arrow as shown below) and follow the instructions. Wait until you get a message saying that you can safely unplug the device before disconnecting the USB cable.

1. The safe remove icon is in the system tray next to the clock.



Windows® XP



Windows® 2000 & Windows® ME

2. Click on the icon to eject (unmount) the Gmini™ 500 from the computer and select the 'Safely remove' message.



53

3. There will be a message indicating that it is now safe to disconnect the Gmini™ 500. You can now safely unplug the USB cable from your Gmini™ 500 and/or computer.



Hard Drive Mode & Macintosh®



Drag the Gmini™ 500 hard drive icon towards the trash can, the trash can will become a big arrow as shown in the screen shot to the left. Drop the hard drive icon onto the arrow. The hard drive icon will disappear from the desktop. You can now safely unplug the USB cable from your Gmini™ 500 and/or computer.

14 Connecting Devices to the USB Host Port

Thanks to the USB Host port, you can connect USB Mass Storage Class (MSC) devices such as many digital cameras and external hard drives in order to transfer pictures or data to/from your Gmini™ 500. Check your manufacturer's information to find out whether your device is an MSC device. Non Mass Storage Class devices such as printers, Ethernet adapters, mice, keyboards, etc. are not supported.

To connect an MSC device, use the included short USB host adapter.



If your camera follows the Mass Storage Class (MSC) standard for USB connection, then your camera will show up in the file browser as the folder **/External USB**. In this folder you will see your photos or files. See the chapter on the **Browser** for instructions on how to copy files.

55

56

15 SETTINGS

From the main screen, select the **Settings** action icon to reveal the menu items for various settings.

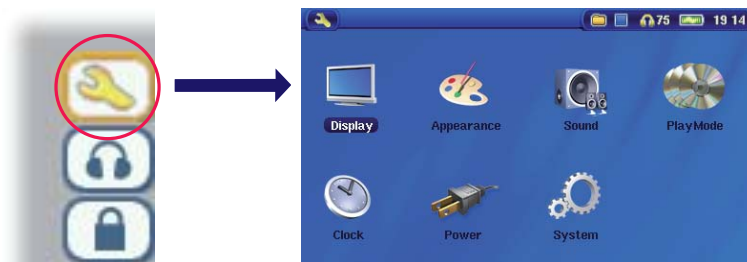

15.1 Sound Settings



If you would like to customize the sound quality, you can adjust the Bass, Treble, and other audio settings to suit your particular taste. Normally you will do this while listening to music so that you can hear the changes you make. Simply click on the **Audio Settings** action icon while listening to music.

- Once in the Settings screen, move over to the **Sound** icon and click again on ENTER **o**. Use LEFT and RIGHT buttons to change a parameter's value. You will hear these changes instantly.
- Use the UP and DOWN buttons to select different parameters.
- Click on STOP/ESC **x** when finished. You will return to the Setup screen.
- Click on STOP/ESC **x** again and you will return to the music playing screen.



56

The Sound Parameters

Parameter	Description
Volume	0 – 99
Bass	10 levels. Decreases or Increases the low frequencies.
Treble	10 levels. Decreases or Increases the high frequencies.
Balance	10 levels. Favors the right or left channel of the Stereo signal.
Bass Boost	10 levels. Increases the very low frequencies.
Reset button	Re-adjusts all settings to their default values.

15.2 Play Mode Settings



If you would like the Gmini™ 500 to play through an entire folder of songs, play songs at random (shuffle), or any of the other playing options, you can set these parameters in the PlayMode settings. Click on the **Settings** action icon from the main menu or while listening to music and then choose **PlayMode**.

Parameter	Description
-----------	-------------

Playmode options

Single	Play a single track then stop.
Folder	Play all tracks in the current directory or current album.
All	Play all tracks on the Gmini™ 500.
Queue	While the current song is playing, select the Show ARCLibrary action button, find the next song you want to play, then click PLAY. This is your queued song. You can only queue one song at a time. See the Playlist section to prepare multiple songs to play. Once the current track is finished playing, your queued track will be played. If you do not queue another track at this time, the Gmini™ 500 will play the next song in the directory.

57

Scan Each track in the directory is played for the duration selected for the parameter **Intro Duration**. This allows a quick sample of each song. If you want to play the whole song, click on the Play button during the "intro". The Gmini™ 500 will then revert to single directory mode and play the rest of the songs in the directory without scanning.

Repeat & Shuffle options

Normal	Plays your songs one after the other and then stops after the last song.
Repeat	Continuously plays through the current set of songs (Artist, Album, folder, or Playlist).
Shuffle	Randomly play through the current set of songs (Artist, Album, folder, or Playlist).

Intro duration From 10 to 90 seconds. This is the time for which each song will be played when selecting **Scan** for **Playmode** settings.

15.3 Clock Settings



The Gmini™ 500 has an internal real time clock. The time of day is shown on the top right of the screen in either 24 hour or 12 hour display mode. To set it, select the **Settings** action icon then select **Clock**.



Choose parameter



Choose value for highlighted parameter



When finished setting the parameters, move down to the **Set** button, then click on the ENTER **o** button. The clock time and date are now set. Click on the STOP/ESC **x** button to go back to the main settings menu.

15.4 Display Settings

These settings regulate the interface language and the presentation of the screen.



Setting

Description

Language	The Gmini™ 500 can be set to English (default), French, German, Spanish, or Russian.
Action icon notes	Displays the explanation or name of the action icons when moving up and down through the menu. If set to On, the first click on the SELECT action button will show the names of the icons. The second click will select the icon.
TV Standard	NTSC (USA), PAL (Europe). In order to view images or videos on an external television, select one option to send the video signal compatible with your country's television system. Countries other than European or American will use one of these two systems.
TV format	4:3 or 13:9 – the ratio at which images are displayed on your television set.
Video Output	Internal LCD or External TV. To display via the built-in LCD screen or to view the display via an external television. Holding the LCD/TV button for two seconds will also alternate between these two options. Be sure your television is selecting the correct external input.
LCD Brightness	0, 1, 2. The 3 brightness levels for the built-in LCD screen. Setting to a lower value will give you a longer battery autonomy.

When accessing the **Display settings** while playing a video you have an additional display option:

Video OSD	Time for which the video On Screen Display information will be shown when the video starts playing.
------------------	---

59

60

15.5 Appearance settings

Setting

Description

Wallpaper	On, Off. When set to On, the selected picture (next item) will be displayed as the Gmini™ 500 screen background.
Picture name	This option will display the names of the JPEG images in the Gmini™ 500's System folder that can be used for screen backgrounds (Wallpaper). You can add your own JPEG images to the System folder by dragging and dropping a JPEG file from your computer. You can also set the wallpaper within the Photo mode.
Font Outline	If your screen background is a dark color, it will be difficult to see the black text on the screen. Set Outlined font to On to have a more visible white outlined font.
Color scheme	Allows you to choose what color you would like to have for the status bar above and the screen buttons.
Cursor color	Changes the color of the cursor and its background.
Previous settings	Click this button to return to the settings last set.



15.6 Power Settings



These settings will help you to save battery power thus allowing a longer battery autonomy.

You can set the Gmini™ 500 to conserve power for both modes of operation (when it is powered from the battery, or when it is connected to the AC charger/adaptor (DC-Power operation)).



60

Parameter	Description
Power Off	1-9 minutes or Never. The number of minutes of user inactivity (no buttons pressed) before the Gmini™ 500 shuts off. During the playback of music or video files, this setting takes effect only after the files are finished playing.
Backlight Off	10-90 seconds or Never. The time of user inactivity (no buttons pressed) before the Gmini™ 500 turns off the screen to conserve power. During the playback of video files, this setting only takes effect once the file is finished playing.
Hard drive	10-90 seconds. The number of seconds from the time of the last file access before the Gmini™ 500 tells the internal hard drive to stop spinning. The longer this time is set, the more often the hard drive is turning and the quicker the response time when accessing files. However, as it is set longer, it will quickly consume your battery. Caution: This setting should only be changed by experienced users.
Standby	1-9 minutes or Never. The number of minutes of user inactivity (no buttons pressed) before the Gmini™ 500 goes into Standby mode. When powered by the AC charger/adaptor (or connected to a powered TV docking pod), the Gmini™ 500 will not completely shut off. It will go into Standby mode. This way, it can wake up to make a scheduled video recording.

A typical use of these settings is to set the power off, screen off, and hard drive to low values when used in battery mode. When the power adapter is plugged in, you do not need to conserve energy and thus keeping the Power on and the Backlight on makes using the Gmini™ 500 more agreeable. Increasing the hard drive value beyond the default may actually discharge the battery even when the Charger/adaptor is plugged in. Note also that your unit will run hotter when the backlight and hard drive are on for long periods of time.

15.7 System Settings



The System settings allow you control over the low level parameters of the Gmini™ 500.

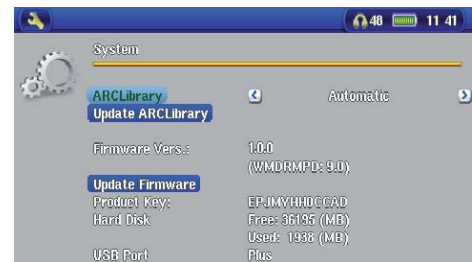

61

Parameter	Description
ARCLibrary	Off: From the Music icon, you will just browse music files in the folder Music . On: (Only in USB Port mode 'Hard drive') Browse music via its tag characteristics but the ARCLibrary must be updated manually. Automatic: ARCLibrary is automatically updated when the USB cable is disconnected from your device.
Update ARCLibrary	This button lets you update the ARCLibrary if you have set the parameter above to ON.
USB Port	Windows Device (default), Hard drive.
Windows Device	When set to , your Gmini™ 500 will use the MTP (Media Transport Protocol) whenever it is connected to a Windows XP (SP1 or higher) operating system with Windows Media® Player 10 installed. It will be seen as the Gmini™ 500 'Device' in Windows® Explorer. WARNING: This will not work for earlier Windows® operating systems or Macintosh® computers.
Hard drive	When set to Hard Drive , your Gmini™ 500 will act as an external hard drive (mass storage device) when connected to a computer. Use this mode for all non-Windows® XP operating systems.
Firmware Version	Displays the current version of the OS (Operating System) and DRM (Digital Rights Management) system.
Update Firmware	Used to update the Gmini™ 500 to a new version of the Operating System. See the chapter Updating the Gmini™ 500 Firmware Operating System .
Product Key	Each Gmini™ 500 device has a unique product key number.
Hard Drive	Displays the amount of free and used space on the Gmini™ 500's hard drive. Reported number of megabytes is binary based counting (1kb=1024 bytes). Thus each reported MB represents approximately 1.05 megabytes (decimal). Formatting also takes up space.

16 Updating the Gmini™ 500 Firmware Operating System (OS)

ARCHOS™ periodically updates the Operating System (OS) and makes it available for free download on the ARCHOS™ website (www.archos.com). Updates to the Operating System include new features, feature improvements, and bug fixes. You should check to make sure that you are running the most recent version of the OS. To check what version you have, click on the **Settings** action icon and then go to **System**. You will find the most recent version of the OS and its version number at the ARCHOS™ website (www.archos.com) under the download section.

Download the Update_Gmini™ 500.AOS file



When you click on the link to download the new OS file (the file name is Update_Gmini500.AOS), your browser may warn you that the contents of the download may harm your computer. This is because the Windows® system does not know what a .AOS file is. Be assured that ARCHOS™ has made every effort to ensure that the file does not contain viruses. Click on the option **Save** to download this file to a convenient place, such as **My Documents**, in order to later copy this file to your Gmini™ 500. If your Gmini™ 500 is connected to your PC, you can even save it directly to the Gmini™ 500.

Read the History.txt File

You will also find next to the firmware download, a text file which details the list of changes from the previous version of the OS.

Copy to the Gmini™ 500

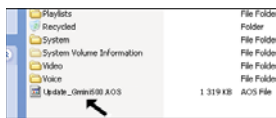

When updating your Operating System, you must keep the AC charger/adaptor plugged into the Gmini™ 500 so that it will not shut down due to low batteries while you are performing the update. Connect your Gmini™ 500 to your computer (refer to the relevant chapter if you are unsure about this), and then copy the Update_Gmini500.AOS file to the Gmini™ 500.

63

64

'Hard Drive' or 'Windows Device'?



Gmini500

If your Gmini™ 500 is seen as a hard drive, then you simply need to drag the Update_Gmini500.AOS file onto this icon, and Windows® will place the file into the top most directory (root) of the Gmini™ 500. It should not be placed inside any folder within your Gmini™ 500. Once this file is copied, safely disconnect (refer to the chapter on Connecting/Disconnecting) the Gmini™ 500 from the computer.



Gmini500

If your Gmini™ 500 is seen as a Windows® Device, then you will have to open the Gmini™ 500 Device in Windows® Explorer and drop the Update_Gmini500.AOS file into the Data folder (not the Media folder). If there is already an older version of the Update_Gmini500.AOS file on your Gmini™ 500, Windows® will ask if you want to overwrite the current file. Click on Yes. Disconnect the Gmini™ 500 from your computer.

Activate the Update

Update Firmware

Ensure that your Gmini™ 500 is still powered through the AC charger/adaptor.

Next, on the Gmini™, go to the **System** parameters from the **Settings** action icon and then move down to Update Firmware and click on it. The Gmini™ 500 will search for the .AOS file. Follow the on-screen instructions. When completed, the Gmini™ 500 will restart and you can go back to this screen to verify that you have updated the firmware to the new version.

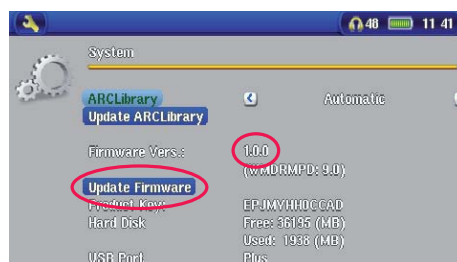

64

17 Replacing the battery

Your Gmini™ 500 has a removable battery. You may want to purchase a second battery for cases when you know that you will be unable to recharge your Gmini™ 500 before the supplied battery runs out. Refer to the chapter **Settings – Power Settings** for information about getting the most use from the battery.

Before removing the battery, disconnect the charger/adaptor and switch off the device.

17.1 “Thin” version

On the “Thin” version of the Gmini™ 500, the battery is located on the left half at the back of the device. To take out the battery, slide the button on the bottom of the Gmini™ 500 towards the right, then slide the battery towards the top and lift it out. To replace the battery, lower it straight into the compartment. Be sure to leave a gap between the bottom edge of the Gmini™ 500 and the battery (1). Slide the battery towards the bottom of the Gmini™ 500. This action should anchor the battery in the compartment (2).

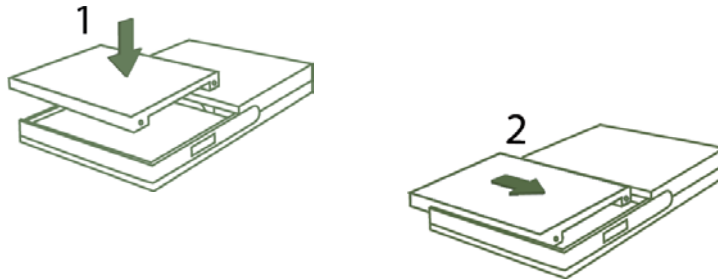

Caution: If the battery is incorrectly replaced or short-circuited, this could result in damage to the product and/or serious injuries to the user. Replace only with same or equivalent type of battery.

65

17.2 Standard version

Your Gmini™ 500 has a removable battery. You may want to purchase a second battery for cases when you know that you will be unable to recharge your Gmini™ 500 before the supplied battery runs out. Refer to the chapter **Settings – Power Settings** for information about getting the most use from the battery.

Before removing the battery, disconnect the charger/adaptor and switch off the device.

Two batteries are available for the Gmini™ 500. They are located on the back of the device and are exchanged in the same way. To take out the battery, move the sliding button on the left hand side of the device downwards. You can now lift the battery from the left edge. To replace a battery, hold it with the 2 plastic notches towards the right and slide it into the battery compartment (1). Then, lower the battery into its compartment (2). Finally, remember to move the slider latch towards the top of the Gmini™ 500 in order to secure the battery inside its compartment (3).

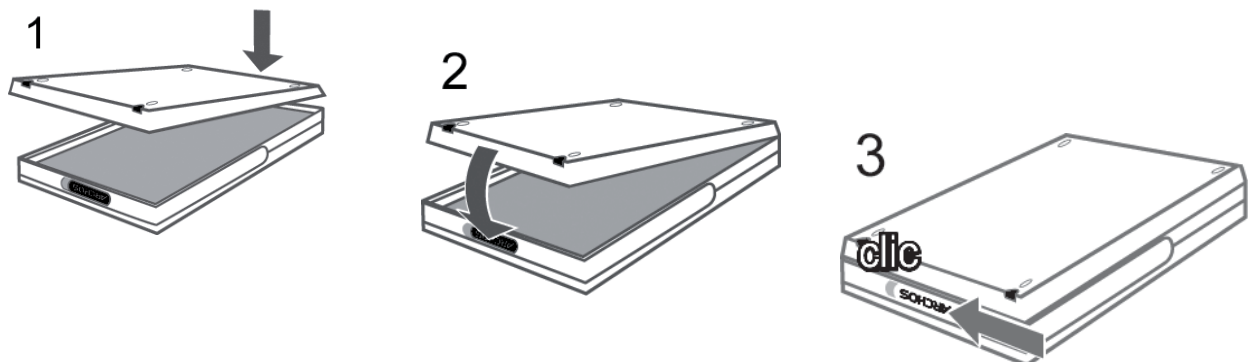

Caution: If the battery is incorrectly replaced or short-circuited, this could result in damage to the product and/or serious injuries to the user. Replace only with same or equivalent type of battery.

18 Technical Support

In case you should encounter any technical difficulties using your product, we suggest you go through these steps in order to resolve any issues as efficiently as possible:

- 1) Please read carefully through the appropriate sections of this manual. Some subject areas may be treated in two different chapters depending on how the device is being used.
- 2) Look at the Troubleshooting section at the back of this manual. In this section, we have included answers to some commonly asked questions.
- 3) Look at our Support section on the website (www.archos.com). Here, you will find Frequently Asked Questions (FAQ) for our different products, and there is a chance that somebody else has already asked your question.
- 4) If these steps did not help you resolve your technical difficulty, you can always contact us either via email or by calling the helpline. Telephone support will be provided in the language of the countries listed below. For other countries, please use e-mail technical support.

- For warranty and services purposes, keep your sales receipt for proof of purchase.
- If technical support (Telephone or E-mail) determines that your product needs to be returned, please contact the place of purchase to have your product repaired or replaced (depending on problem type). Customers who purchased directly from the ARCHOS™ website should fill out the RMA return request form on the website.

DO NOT USE phone or e-mail support for marketing and sales questions. These numbers are to aid those who have technical difficulties / malfunctions.

Telephone Support

Canada	949-609-1400	Nederland	020-50 40 510
Danmark	35 25 65 67	Norge	22 57 77 71
Deutschland	069-6698-4714	Schweitz/Suisse	442 004 111
España	09-1345-6224	Suomi	09 2311 3434
France	01 70 20 00 30	Svenska	08 579 290 80
Ireland	01-601-5700	UK	0207-949-0115
Italia	02-4827-1143	USA	877-300-879 (toll free)

Email Support

tech-support.us@archos.com

English (United States and Canada customers)

tech-support.eu@archos.com

English or French (Europe and the rest of the planet)

tech-support.de@archos.com

German (Germany)

WWW.ARCHOS.COM

Worldwide Offices	
<p>United States & Canada</p> <p>ARCHOS™ Technology 3, Goodyear - Unit A Irvine, CA 92618 USA</p> <p>Phone: 1 949-609-1483 Fax: 1 949-609-1414</p>	<p>Europe & Asia</p> <p>ARCHOS™ S.A. 12, rue Ampère 91430 Igny France</p> <p>Phone: +33 (0) 169 33 169 0 Fax: +33 (0) 169 33 169 9</p>
<p>United Kingdom</p> <p>ARCHOS™ (UK) Limited PO Box 1420 Southampton SO15 1WF United Kingdom</p> <p>Phone: +44 (0) 1264 366022 Fax: +44 (0) 1264 366626</p>	<p>Germany</p> <p>ARCHOS™ Deutschland GmbH Business Park Vierwinden Konrad-Zuse-Str. 22 41516 Grevenbroich Germany</p> <p>Tel: + 49 (0) 21 82 – 570 41-0 Fax: + 49 (0) 2182/57041-70</p>

69

70

19 Troubleshooting

19.1 USB Connection issues

Problem: I cannot get my Gmini™ 500 to be recognized by the computer or it asks for a driver.

Solutions:

- If you are running an operating system other than Windows® XP (Service Pack 1 minimum) with Windows Media® Player 10 or higher, the USB Port setting should be set to 'Hard Drive'. Go to **Settings > System > USB Port** and set it to '**Hard Drive**'. Only Windows® XP (Service Pack 1 or higher) with Windows Media® Player 10 or higher will allow for the USB Port '**Windows Device**' setting.
- Shut off and reboot the computer and the Gmini™ 500 and then try connecting again in the preferred order mentioned in the chapter **Connecting/Disconnecting the Gmini™ 500 to/from your PC**.
- If using a USB hub, try connecting without using the hub (some hubs are not powered and may not work with the Gmini™ 500).
- If using a USB port in the front of your computer, try a USB port in the back. Front USB ports are often from non-powered hubs.
- Do not connect to a USB port repeated through a keyboard.
- If using a laptop computer and a docking station, try connecting without the docking station.
- Macintosh® users must update to OS 10.2.4 or higher.
- (Hard Drive mode) If the Files Allocation Table (FAT) gets corrupted, the Gmini™ 500 may not show up in Windows XP for over one minute, and then it comes up as **local drive**. Use DOS Utility **ChkDsk** as shown below.
- (Hard Drive Mode) Windows® XP may recognize the Gmini™ 500 hard drive but yet not assign a drive letter to it. Right click on **My Computer** and select **Manage**. Then select **Storage**, then **Disk Management**. Within this window you may see the hard drive and be able to assign a drive letter by right-clicking on the hard drive, and selecting the option **Change drive letter and paths...**

Problem: (Hard Drive mode) What do I do if I try to disconnect via the green arrow but keep getting "The device 'Generic Volume' cannot be stopped now. Try stopping the device again later."

Answer: Shut off any program that might be accessing data on the Gmini™ 500, including Windows® Explorer. If this does not work, shut down all programs, wait 20 seconds, then try the green arrow one or two times again. If this does not work, you can shut off your Gmini™ 500 with the Stop/Esc button and then unplug it.

19.2 Charging and Power issues

You do not need to fully discharge the batteries before recharging them.

Problem: A full battery charge does not last as long as the specifications suggest.

Answer: The specifications are under the condition that the screen backlight goes off after 30 seconds (for music) and the user does not access the machine, it just sits and plays. If you get significantly less time from a full charge, call our technical support hot-line.

19.3 Gmini™ 500 locks up (freezes operation) or Stops

Problem: The Gmini™ 500 locks-up. None of the buttons work.

Solution: If the 'Lock buttons' is set, none of the buttons respond. Hold down the unlock action button for three seconds to turn off the 'Lock buttons' function. A freeze up could also be caused by electrostatic phenomena. That is, static electricity has temporarily knocked out the Gmini™ 500. Hold down on the STOP/OFF button for 15 seconds and the Gmini™ 500 will shut off. Restart it normally now.

19.4 File issues, corrupted data, formatting, and partitioning

Problem: I want to clean up my Gmini™ 500's hard drive, but Windows® will not let me use the standard hard drive cleaning tools.

Answer: This is because Windows® sees your Gmini™ 500 as a Windows Device and not a hard drive (USB Port is set to **Windows Device** in **Setup > System**). **Do not change back to hard drive** and run a defragmenter program. This will give unexpected results.

Problem: On the Gmini™ 500, I find new file names and folder names that I never created and/or they have strange gibberish names.

Answer: (Hard drive mode) Most likely, the Gmini™ 500's file allocation table (FAT) has been corrupted. This could have been due to the Gmini™ 500 shutting down (due to low battery power) while reading or writing to your computer via the USB connection. To fix a corrupted FAT problem, you should use the Error Checking utility or the Check Disk utility explained at the end of this section. Attention: Windows and Macintosh often write extra files to the hard drive such as **finder.def** or **System volume info**. These are normal and will not harm the Gmini™ 500.

Problem: Can I defragment the Gmini™ 500's hard drive?

Answer: (Windows Device Mode) The Gmini™ 500 maintains an optimized file system and does not need to be defragmented. Defragmenting will cause unexpected problems.

Problem: I want to reformat the Gmini™ 500's hard drive.

Answer: You can do this, but it will erase ALL of the data on your Gmini™ 500. Sometimes this may be necessary if your FAT (File Allocation Table) becomes so corrupted that nothing seems to fix your file problems. First, as explained below, you should run ScanDisk or the DOS chkdsk (Check Disk) program to try to fix your problem. If this doesn't fix your problem and you are sure you must reformat the Gmini™ 500 hard drive, then go to the screen **Settings > System** and press and hold the DOWN action button for three seconds. A button "Format HD" will appear. Use this button to format the Gmini™ 500's hard drive. Remember, doing this will erase all the data on the Gmini™ 500's hard drive!!!

Windows® ME Running Scan-Disk (Error Checking) – HARD DRIVE mode only

- Quit all running applications.
- Properly connect the Gmini™ 500 to your computer as explained in the chapter **Connecting/disconnecting the Gmini™ 500 to/from your PC**.
- Make sure external AC adapter is powering the Gmini™ 500.
- Right click on the Gmini™ 500 hard drive in Windows® Explorer and select Properties.
- Select the Tools option and run the Error checking program.
- Make sure you check the box to **automatically fix errors**.

- Be patient, this may take a while.

Windows® XP & 2000 Running Check Disk Utility (Chkdsk) – HARD DRIVE mode only

If you still have problems with the file system on your Gmini™ 500 you can try to fix it using the DOS utility, check disk (chkdsk). Do the following;

- Make sure external AC adapter is powering the Gmini™ 500.
- Quit all running applications.
- Properly connect the Gmini™ 500 to your computer as explained in chapter **Connecting/disconnecting the Gmini™ 500 to/from your PC**.
- Wait patiently (up to 5 minutes) for Windows XP to show the local drive as mounted.
- Open a DOS window. Programs > Accessories > Command Prompt.
- At the prompt, type **chkdsk e: /f**. Use e: or f: or whatever drive letter is representing your Gmini™ 500. The /f argument tells the program to automatically fix errors.
- Be patient, this may take a while.
- When finished, exit the DOS Window and properly disconnect the Gmini™ 500 from your computer.

20 Technical Specifications

ARCHOS™ Gmini™ 500

Storage Capacity	See packaging for internal hard drive size
Display	4" LCD 480x272 pixels, 262 000 colors and TV output ¹
Video playback	MPEG-4 SP with B-Frames ² with stereo sound. Near DVD quality up to 720x480 @ 30 f/s (NTSC), 720x576 @ 25 f/s (PAL), AVI file format. WMV9 Simple Profile up to 352x288 @ 30 f/s and 800Kbit/s.
Audio recording	From an analog source in stereo sound for WAV (PCM & ADPCM) format.
Audio Playback	Stereo MP3 decoding @ 30-320 kb/s CBR & VBR, WMA with protected files, WAV (PCM & ADPCM)
Photo viewer	JPEG (not progressive jpegs) and BMP formats
AV Connections	Earphones Audio & Video line out (TV output).
Television output	Video output in PAL (EU) or NTSC (US) standard
Computer Interface	USB 2.0 high-speed device, compatible USB 1.1, PC & Mac. USB Host port compatible Mass Storage Device ³ .
Playback Autonomy*	Up to 16 hours for music. Up to 4.15 hours for video on the built-in LCD.
Scalability	Free Operating System updates downloadable from ARCHOS™ website
Power source	Rechargeable Lithium-Ion battery External: AC charger/adapter. Use ONLY the specified Archos adapter/charger supplied with this product.
Physical Dimensions	Approx.: 7.6 x 12.4 x 1.8/2.4 cm - 3" x 4.9" x 0.7"/0.9" ; weight: 256/312 g (slim/standard version)
Temperature Range	5 °C to 35 °C running ; -20 °C to 45 °C storage



Minimum Requirements

Computer configuration:

PC with Windows® ME, or 2000, and USB 2.0 port.

Macintosh® G3 with MAC OS v10.2.4 or higher, Macintosh® G3 and USB 2.0 port.

For Playsforsure™ content:

PC with Windows® XP SP1 or higher operating system, Windows Media® Player 10 or higher, and USB 2.0 port.

**Depending on usage (stop/start/writing)*

(1) *External video output disabled for Marcovision®-protected contents.*

(2) *DivX: has not been certified by DivX, Inc., may not read all DivX® 4.0, 5.0 & 6.0 files; does not read Divx® 3.11 files. MPEG-4: ISO standard by Moving Picture Experts Group ; AVI: audio/video file container by Microsoft. MPEG-4 SP with B-frames AVI up to 720x480@30f/s NTSC or 720x576@25f/s PAL..*

(3) *Only cameras compatible with Mass Storage Class USB.*

All brands and product names are registered trademarks and the property of their respective owners. Specifications are subject to change without notice. Errors or omissions excepted. Images and illustrations may not always match contents. Copyright© 2005. ARCHOS. All rights reserved.

21 Legal

Warranty and Limited Liability

This product is sold with a limited warranty and specific remedies are available to the original purchaser in the event the product fails to conform to the limited warranty. Manufacturer's liability may be further limited in accordance with its sales contract.

In general, the manufacturer shall not be responsible for product damages caused by natural disasters, fire, static discharge, misuse, abuse, neglect, improper handling or installation, unauthorized repair, alteration or accident. In no event shall the manufacturer be liable for loss of data stored on disk media.

MANUFACTURER SHALL NOT BE LIABLE FOR ANY SPECIAL, INCIDENTAL OR CONSEQUENTIAL DAMAGES. EVEN IF INFORMED OF THE POSSIBILITY THEREOF IN ADVANCE.

ARCHOS™ licensor(s) makes no warranties, express or implied, including, without limitation, the implied warranties of merchantability and fitness for a particular purpose, regarding the licensed materials. ARCHOS's licensor(s) does not warrant, guarantee or make any representations regarding the use or the results of the use of the licensed materials in terms of its correctness, accuracy, reliability, correctness or otherwise. The entire risk as to the results and performance of the licensed materials is assumed by you. The exclusion of implied warranties is not permitted by some jurisdictions. The above exclusion may not apply to you.

In no event will ARCHOS's licensor(s), and their directors, officers, employees or agents (collectively ARCHOS' licensor) be liable to you for any consequential, incidental or indirect damages (including damages for loss of business profits, business interruption, loss of business information, and the like) arising out of the use of inability to use the licensed materials even if ARCHOS' licensor has been advised of the possibility of such damages. Because some jurisdiction do not allow the exclusion or limitation of liability for consequential or incidental damages, the above limitations may not apply to you.

Please see your sales contract for a complete statement of warranty rights, remedies and limitation of liability.

Furthermore, warranty does not apply to:

1. Damages or problems resulting from misuse, abuse, accident, alteration or incorrect electrical current or voltage.
2. Any product tampered-with or damaged warranty seal or serial number label.

3. Any product without a warranty or serial number label.
4. Batteries and any consumable items delivered with or in the equipment.

Warnings and Safety Instructions

CAUTION

To prevent risks of electric shock, this unit must only be opened by qualified service personnel.

Power off and disconnect the power supply cable before opening the unit.

WARNING

To prevent fire or shock hazard, do not expose the unit to rain or moisture.

Use of this product is for personal use only. Copying CDs or loading music, video, or picture files for sale or other business purposes is or may be a violation of copyright law. Copyrighted materials, works of art, and/or presentations may require authorization to be fully or partially recorded. Please be aware of all such applicable laws concerning the recording and use of such for your country and jurisdiction.

FCC Compliance Statement

FCC Compliance

This equipment has been tested and found to comply with limits for a Class B digital device, pursuant to Part 15 of the FCC Rules. These limits are designed to provide reasonable protection against harmful interference in a residential installation. This equipment generates, uses and can radiate radio frequency energy and, if not installed and used in accordance with instructions, may cause harmful interference to radio communications. However, there is no guarantee that interference will not occur in a particular installation. If this equipment does cause harmful interference to radio or television reception, which can be determined by turning the equipment off and on, the user is encouraged to try to correct the interference by one or more of the following measures:

- Reorient or relocate the receiving antenna.
- Increase the separation between the equipment and receiver.
- Connect the equipment into an outlet on a circuit different from that to which the receiver is connected.
- Consult the dealer or an experienced radio/TV technician for help.

CAUTION : Modifications not authorized by the manufacturer may void users authority to operate this device.

FCC Part 15 – Operation is subject to the following two conditions:

1. This device may not cause harmful interference;
2. This device must accept any interference received including interference that may cause undesired operation.

Electrostatic Discharge

Note: During electrostatic discharge, the product may be malfunctioning. Reset to return normal operation. The Gmini™ 500 reset is actuated by pressing and holding the STOP/ESC button for 15 seconds. The unit will power off. Restart normally.

Avoiding Hearing Damage

This product respects the current regulations for limiting the output volume of consumer audio devices to a safe level. By listening to your device with headphones or earbuds at high volumes, you run the risk of permanent damage to your ears. Even if you get used to listening at high volumes and it seems normal to you, you still risk the possibility of damaging your hearing. Reduce the volume of your device to a reasonable level to avoid permanent hearing damage. If you hear ringing in your ears, reduce the volume or shut off your device. This device has been tested with the ARCHOS™ supplied earphones. Other manufactures earphones may produces volume levels higher or lower than the ARCHOS™ delivered earphones.

Copyright Notice

Copyright ARCHOS™ © 2005 All rights reserved.

This document may not, in whole or part, be copied, photocopied, reproduced, translated or reduced to any electronic medium or machine-readable form without prior consent, in writing, from ARCHOS. All brands and products names are registered trademarks and the property of their respective owners. Specifications are subject to change without notification. Errors and omissions accepted. Images and illustrations may not always match contents. Copyright © ARCHOS. All rights reserved.

Disclaimer of warranty: to the extent allowed by applicable law, representations and warranties of non-infringement of copyrights or other intellectual property rights resulting from the use of the product under conditions other than as here above specified, are hereby excluded.

LCD Pixel Policy

The LCD screen on your ARCHOS™ Gmini™ 500 unit has been manufactured to rigorous standards to provide a high quality viewing experience. Nevertheless, your LCD screen may have slight imperfections. This is not particular to the ARCHOS™ screen, but to all devices which have LCD screens regardless of the original manufacturer of the LCD. Each product vendor guarantees that his screen will contain no more than a certain number of defective pixels. Each screen pixel contains three dot elements (Red, Blue, and Green). One or all of the dots in a given pixel may be stuck on or stuck off. A single dot stuck off is the least noticeable. All three dots of a pixel stuck on is the most noticeable. ARCHOS™ guarantees that its Gmini™ 500 screen will have no more than 2 defective pixel (regardless if these pixels have one or more defective dots). This means that during the period of guarantee for your country or jurisdiction, if the screen on your product has three or more defective pixels, ARCHOS™ will repair or replace your Gmini™ 500 product at its cost. Thus, two or less defective pixels is not grounds for replacement or repair of the product.

Environmental Considerations

Protection of the environment is an important concern to ARCHOS™. In order to put this concern into tangible actions, ARCHOS™ has consciously included a set of methods that favor a respect for the environment into the entire cycle of its products; from fabrication to consumer usage, to final disposal.

Batteries : If your product contains a detachable battery pack, you should only dispose of it in a designated collection point for used batteries.

The Product : The crossed-out garbage can symbol on your product signifies that it falls into the category of electric/electronic equipment. Products of this type contain substances that are potentially dangerous to the environment and to human health. Therefore, you should not dispose of the ARCHOS electronic device in a regular trash. As such, the current European directives ask that this device be collected:

- At places of distribution in the case of a purchase of a similar electronic product.
- At locally created disposal areas (waste disposal centers, sorted trash system, etc.)

By doing this, you are actively participating in the reuse and recycling of disposed electronic and electric equipment that could have potential effects on the environment and human health.



22 Index

*Please note: This index refers to both the abridged USER GUIDE and the complete PDF user manual (this document). References to this PDF user manual are marked *.*

Activating panel

MUSIC – Creating a Playlist	8.2*	
BROWSER – Using the Browser	12*	7

ARCLibrary

MUSIC – Playing Music Files	6*	6
MUSIC – Browsing through your Music Library	6.3*	
SETTINGS – System Settings	15.6*	10.2

ARCLibrary update

MUSIC – Browsing through your Music Library	6.3*	
SETTINGS – System Settings	15.2*	

Audio recording/editing

MUSIC – Recording Music – Audio Editing	9*,9.4*	
---	---------	--

Available disc space

SETTINGS – System Settings	15.6*	10.2
----------------------------	-------	------

Background image (Wallpaper)

SETTINGS – Appearance Settings	15.5*	
--------------------------------	-------	--

Battery autonomy and consumption

Connecting/Disconnecting the Gmini™ 500 to/from your PC	13*	8
SETTINGS – Power Settings	15.5*	
Battery replacement	17*	

Bookmarks

VIDEO – Playing Video Files – Set a bookmark	3.1*	
MUSIC – Setting a Bookmark	6.5*	

Buttons not working

MUSIC – Button Control	6.1*	4.1
------------------------	------	-----

Card readers

PHOTO – Transferring photos to your AV	11.3*	6.2
--	-------	-----

Codecs		
VIDEO – Installing the PC Software – MPEG-4 Codec (Compression/Decompression)	5.1*	
VIDEO – Installing the PC Software – MP3 Sound Codec	5.1*	
Compression		
VIDEO – Playing Video Files from the Internet	4*	
VIDEO – Creating MPEG-4 Video Files with your Computer	5*	
MUSIC – Putting Music onto your Gmini™ 500	7*	
Connecting 2 USB devices		
Connect Devices to the USB Host Port	14*	9
Date and time		
SETTINGS – Clock Settings	15.3*	10.1
Default location		
MUSIC – Where is the Recording Saved?	9.3*	
Delete Playlist		
MUSIC – Playing a Playlist	8.1*	
BROWSER – Using the Browser	12*	
Delete section from audio file		
MUSIC – Audio Editing	9.4*	
Delete song from Playlist		
MUSIC – Saving a Playlist	8.3*	
Deleting files		
BROWSER – File and Folder Operations	12.2*	
Display		
SETTINGS – Display settings	15.4*	
Equalizer		
SETTINGS – Sound Settings – Sound parameters	15.1*	
External speaker off/on		
VIDEO – Video Playback Action Icons – Built-in speakers	3.1*	
SETTINGS – Sound Settings – Sound parameters	15.1*	
File system		
BROWSER – Using the Browser	12*	7
Files: Locating a file		
MUSIC – Browsing through your Music Library	6.3*	
MUSIC – Where is the Recording Saved?	9.3*	
BROWSER - Navigating the directory structure	12.1*	7.1

Files: Moving or copying files		
MUSIC – Transferring CD collection to the AV	7.3*	
MUSIC – Using iTunes™ with your Gmini™ 500	10*	
PHOTO – Transferring photos to your Gmini™ 500	11.3*	6.2
BROWSER – Using the Browser	12*	
Connect Devices to the USB Host Port	14*	
Files: Music deleted from your device		
Synchronizing Music from Windows Media® Player to the Gmini™ 500	7.1*	5.1
Find a particular song (Scan)		
MUSIC – Play Screen Icons	6.2*	
SETTINGS – Play Mode Settings	15.2*	
Foreign character sets		
INTRO – First time usage – Foreign character sets	2.5*	
Frame rates for video files		
VIDEO – Non Protected Internet Video Content	4.1*	
Free disc space		
SETTINGS – System Settings	15.6*	10.2
Lock		
MUSIC – Button Control	6.1*	4.1
MPEG-4 Translator		
VIDEO – Creating MPEG-4 Video Files with your Computer	5*	
Music Browser		
MUSIC – Playing Music Files	6*	4
MUSIC – Browsing through your Music Library	6.3*	
Music deleted/missing from your device		
MUSIC – Synchronizing Music from Windows Media® Player (WMP) to the Gmini™ 500	7.1*	5.1
Music files sorted by categories		
MUSIC – Playing Music Files	6*	4
MUSIC – Browsing through your Music Library	6.3*	
Music lists (Playlists)		
MUSIC – Playing Music Files	6*	
MUSIC – Playlists	8*	
New music not showing in the ARCLibrary		
MUSIC – Browsing through your Music Library	6.3*	
SETTINGS – System Settings	15.6*	

New Playlist does not display		
SETTINGS – System Settings	15.6*	
NTSC		
SETTINGS – Display Settings	15.4*	
Operating system		
SETTINGS – System Settings	15.6*	10.2
Updating the Gmini™ 500 Firmware/OS	16*	11
Operating system Version		
SETTINGS – System Settings	15.6*	10.2
PAL		
SETTINGS – Display Settings	15.4*	
Play songs randomly (Shuffle)		
MUSIC – Play Screen Icons	6.2*	
MUSIC – Saving a Playlist	8.3*	
SETTINGS – Play Mode Settings	15.2*	
Playing only certain songs (Playlists)		
MUSIC – Playing Music Files	6*	
MUSIC – Playlists	8*	
Playing songs in a specific order		
MUSIC – Playing Music Files	6*	
MUSIC – Playlists	8*	
Playlists		
MUSIC – Playing Music Files	6*	
MUSIC – Playlists	8*	
PlaysForSure		
MUSIC – Putting Music onto your Gmini™ 500	7*	5
Protected files		
VIDEO – Playing Video Files from the Internet	4*	
MUSIC – Comparison of Windows Media Player 10 to Windows Media Player 9	7.2*	5.2
MUSIC – Using iTunes™ with your Gmini™ 500	10*	
Recording from a Vinyl or audio tape		
MUSIC – Recording Procedure – Incremental Recording	9.2*	
Removing files		
BROWSER – Using the Browser	12*	

Renaming files or folders		
BROWSER – Using the Browser	12*	
Repeat a song		
SETTINGS – Play Mode Settings	15.2*	
Restarting your device		
INTRO – Hardware Reset	2.7*	
Ripping a CD		
MUSIC – Transferring your CD collection to AV	7.3*	
Screen format		
VIDEO – Playing video files :Set Screen format	3.1*	
Show songs added to device		
SETTINGS – System Settings	15.2*	
Shuffle		
MUSIC – Play Screen Icons	6.2*	
MUSIC – Saving a Playlist	8.3*	
SETTINGS – Play Mode Settings	15.2*	
Slideshow		
PHOTO – Viewing photos – Viewing Slideshow	11.2*	
Slow motion		
VIDEO – Playing video files : Slow motion	3.1*	
Sound		
VIDEO – Creating MPEG-4 Video Files with your Computer	5*	
MUSIC – Playing Music Files	6*	
MUSIC – Playing Through your Stereo System	6.4*	
MUSIC – Recording Procedure	9.2*	
SETTINGS – Sound Settings – Sound parameters	15.1*	
Speakers		
VIDEO – Playing video files: Built-in speakers	3.1*	
MUSIC – Playing music files – Playing through your Stereo System	6.4*	
Tags		
MUSIC – Browsing through your Music Library	6.3*	
Text on screen during video playback (OSD)		
VIDEO – Video Playback Action Icons – On Screen Display (OSD) off	3.1*	
SETTINGS – Display Settings	15.4*	

Thumbnails		
VIDEO – Playing Video Files – Video Browser Action Icons	3*	
VIDEO – Playing video files: Save as Thumbnail	3.1*	
Time and date		
SETTINGS – Clock Settings	15.3*	10.1
Troubleshooting	19*	
Version of the Operating system/firmware		
SETTINGS – System Settings	15.6*	10.2
Video file size and frame rates		
VIDEO – Non Protected Internet Video Content	4.1*	
VIDEO – Using MPEG-4 Translator	5.2*	
Video files: supported formats		
VIDEO – Non Protected Internet Video Content	4.1*	
VIDEO – Creating MPEG-4 Video Files with your Computer	5*	
Video quality		
VIDEO – Creating MPEG-4 Video Files with your Computer	5*	
SETTINGS – Sound Settings – Sound parameters	15.1*	
Virtual Dub		
VIDEO – Creating MPEG-4 Video Files with your Computer – PC Tools	5*	
VIDEO – Installing PC Software – Virtual Dub™	5.1*	
VIDEO – Using MPEG-4 Translator	5.2*	
Virtual keyboard		
BROWSER – Using the Browser – Using the Virtual Keyboard	12.3*	
Windows Media Player		
MUSIC – Synchronizing Music from Windows Media® Player to the Gmini™ 500	7.1*	5.1
Zoom		
PHOTO – Viewing Photos – Magnifying Photos	11.1*	