

RICOH

Aficio

220/270

OPERATING INSTRUCTIONS COPY REFERENCE

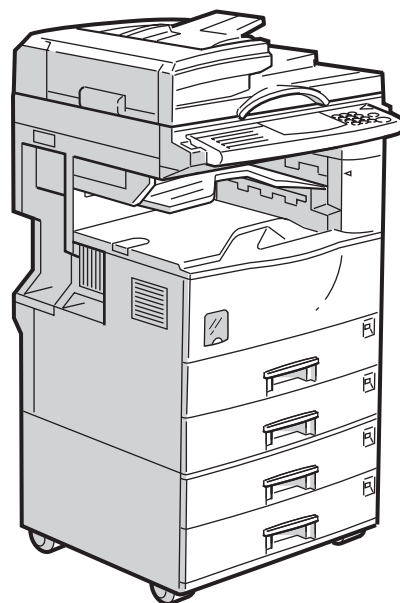

Read this manual carefully before you use this product and keep it handy for future reference.

For safety, please follow the instructions in this manual.



RICOH COMPANY, LTD.

15-5, 1 chome, Minami-Aoyama, Minato-ku, Tokyo
Telephone: Tokyo 3479-3111

Overseas Affiliates

U.S.A.

RICOH CORPORATION
5 Dedrick Place
West Caldwell, New Jersey 07006
Phone: +1-973-882-2000

The Netherlands

RICOH EUROPE B.V.
Groenelaan 3, 1186 AA, Amstelveen
Phone: +31-(0)20-5474111

United Kingdom

RICOH UK LTD.
Ricoh House,
1 Plane Tree Crescent, Feltham,
Middlesex, TW13 7HG
Phone: +44-(0)181-261-4000

Germany

RICOH DEUTSCHLAND GmbH
Mergenthalerallee 38-40,
65760 Eschborn
Phone: +49-(0)6196-9060

France

RICOH FRANCE S.A.
383, Avenue du Général de Gaulle
BP 307-92143 Clamart Cedex
Phone: +33-(0)1-40-94-38-38

Spain

RICOH ESPAÑA S.A.
Avda. Litoral Mar, 12-14,
08005 Barcelona
Phone: +34-(0)93-295-7600

Italy

RICOH ITALIA SpA
Via della Metallurgia 12,
37139 Verona
Phone: +39-(0)45-8181500

Hong Kong

RICOH HONG KONG LTD.
23/F., China Overseas Building,
139, Hennessy Road,
Wan Chai, Hong Kong
Phone: +852-2862-2888

Singapore

RICOH ASIA PACIFIC PTE.LTD.
260 Orchard Road,
#15-01/02 The Heeren,
Singapore 238855
Phone: +65-830-5888

Introduction

This manual contains detailed instructions on the operation and maintenance of this machine. To get maximum versatility from this machine all operators should carefully read and follow the instructions in this manual. Please keep this manual in a handy place near the machine.

Please read the Safety Information before using this machine. It contains important information related to USER SAFETY and PREVENTING EQUIPMENT PROBLEMS.



Notes:

Some illustrations may be slightly different from your machine.

Certain options may not be available in some countries. For details, please contact your local dealer.



Operator Safety:

This machine is considered a CDRH Class I laser device, safe for office/EDP use. The machine contains a 5-milliwatt, 760 – 800 nanometer wavelength, GaAlAs laser diode. Direct (or indirect reflected) eye contact with the laser beam may cause serious eye damage. Safety precautions and interlock mechanism have been designed to prevent any possible laser beam exposure to the operator.

Laser Safety:

The Center for Devices and Radiological Health (CDRH) prohibits the repair of laser-based optical unit in the field. The optical housing unit can only be repaired in a factory or at a location with the requisite equipment. The laser subsystem is replaceable in the field by a qualified Customer Engineer. The laser chassis is not repairable in the field. Customer engineers are therefore directed to return all chassis and laser subsystems to the factory or service depot when replacement or the optical subsystem is required.

Warning:

Use of controls or adjustment or performance of procedures other than those specified in this manual might result in hazardous radiation exposure.

Notes:

The model names of the machines do not appear in the following pages. Check the type of your machine before reading this manual. (For details, see ⇒ P.4 “Machine Types”.)

- Type 1: Aficio 220
- Type 2: Aficio 270

Certain types might not be available in some countries. For details, please contact your local dealer.

Two kinds of size notation are employed in this manual. With this machine refer to the inch version.

For good copy quality, Ricoh recommends that you use genuine Ricoh toner.

Ricoh shall not be responsible for any damage or expense that might result from the use of parts other than genuine Ricoh parts in your Ricoh office product.

Power Source:

120V, 60Hz, 12A or more

Please be sure to connect the power cord to a power source as above. For details about the power source, see ⇒ P.131 “Power Connection”.

USA (This information is for facsimile option users only.)

❖ FCC Requirements

1. This equipment complies with Part 68 of the FCC rules. On the cover of this equipment is a label that contains, among other information, the FCC registration number and ringer equivalence number (REN) for this equipment. If requested, this information must be provided to the telephone company.
2. This equipment uses the following USOC jack: RJ11C
3. The REN is used to determine the quantity of devices which may be connected to the telephone line. Excessive REN's on the telephone line may result in the devices not ringing in response to an incoming call. In most, but not all areas, the sum of the REN's should not exceed five (5.0). Contact the telephone company to determine the maximum REN for the calling area.
4. If this equipment causes harm to the telephone network, the telephone company will notify you in advance that temporary discontinuance of service may be required. If advance notice is not practical, the telephone company will notify the customer as soon as possible. Also, you will be advised of your right to file a complaint with the FCC if you believe it is necessary.
5. The telephone company may make changes in its facilities, equipment, operations, or procedures that could affect the operation of the equipment. If this happens, the telephone company will provide advance notice in order for you to make necessary modifications in order to maintain uninterrupted service.
6. In the event of operation problems (document jam, copy jam, communication error indication), refer to the solving problems section in this manual.
7. If you cannot correct the problem, please contact the RICOH CORP. CUSTOMER SUPPORT DEPT. at 1-800-FASTFIX for repair and warranty information. If it is causing harm to the telephone network, the telephone company may request you to disconnect the equipment from the network until the problem is resolved.
8. This equipment cannot be used on telephone company-provided coin service. Connection to Party Line Service is subject to state tariffs.

❖ WHEN PROGRAMMING EMERGENCY NUMBERS AND/OR MAKING TEST CALLS TO EMERGENCY NUMBERS:

1. Remain on the line and briefly explain to the dispatcher the reason for the call before hanging up.
2. Perform such activities in the off-peak hours, such as early morning hours or late evenings.

CANADA (This information is for facsimile option users only.)

The Industry Canada label identifies certified equipment. This certification means that the equipment meets telecommunications network protective, operational, and safety requirements as prescribed in the appropriate Terminal Equipment Technical Requirements document(s). The department does not guarantee the equipment will operate to the user's satisfaction.

Before installing this equipment, users should ensure that it is permissible to be connected to the facilities of the local telecommunications company. The equipment must also be installed using an acceptable method of connection. The customer should be aware that compliance with the above conditions may not prevent degradation of service in some situations.

Repairs to certified equipment should be coordinated by a representative designated by the supplier. Any repairs or alterations made by the user to this equipment, or equipment malfunctions, may give the telecommunications company cause to request the user disconnect the equipment.

Users should ensure for their own protection that the electrical ground connections of the power utility, telephone lines, and internal metallic water pipe system, if present, are connected together. This precaution may be particularly important in rural areas.

Caution: Users should not attempt to make such connections themselves, but should contact the appropriate electric inspection authority, or electrician, as appropriate.

The Ringer Equivalence Number (REN) assigned to each terminal device provides an indication of the maximum number of terminals allowed to be connected to a telephone interface. The termination on an interface may consist of any combination of devices subject only to the requirement that the sum of the Ringer Equivalence Numbers of all the devices does not exceed 5.

In accordance with IEC 60417, this machine uses the following symbols for the main power switch:

- I** means POWER ON.
- ⏻** means STAND BY.

Safety Information

When using your machine, the following safety precautions should be always followed.

Safety During Operation

In this manual, the following important symbols are used:

 **WARNING:**
Ignoring this warning could cause serious injury or even death.

 **CAUTION:**
Ignoring this caution could cause injury or damage to property.

⚠ WARNING:

- ***Connect the power cord directly into a wall outlet and never use an extension cord.***
- ***Disconnect the power plug (by pulling the plug, not the cable) if the power cable or plug becomes frayed or otherwise damaged.***
- ***To avoid hazardous electric shock or laser radiation exposure, do not remove any covers or screws other than those specified in this manual.***
- ***Turn off the power and disconnect the power plug (by pulling the plug, not the cable) if any of the following conditions exists:***
 - ***You spill something into the equipment.***
 - ***You suspect that your equipment needs service or repair.***
 - ***Your equipment's cover has been damaged.***
- ***Do not incinerate spilled toner or used toner. Toner dust might ignite when exposed to an open flame.***
- ***Disposal can take place at our authorized dealer or at appropriate collection sites.***
- ***Dispose of the used toner bottle in accordance with the local regulation.***

⚠ CAUTION:

- *Protect the equipment from dampness or wet weather, such as rain, snow, and so on.*
- *Unplug the power cord from the wall outlet before you move the equipment. While moving the equipment, you should take care that the power cord will not be damaged under the equipment.*
- *When you disconnect the power plug from the wall outlet, always pull the plug (not the cable).*
- *Do not allow paper clips, staples, or other small metallic objects to fall inside the equipment.*
- *Keep toner (used or unused) and toner bottle out of the reach of children.*
- *For environmental reasons, do not dispose of the equipment or expended supply's wastes at household waste collection point. Disposal can take place at our authorized dealer or at appropriate collection sites.*
- *The inside of the machine could be very hot. Do not touch the parts with a label indicating the "hot surface". Otherwise it could cause a personal burn.*
- *Our products are engineered to meet high standards of quality and functionality, and we recommend that you only use the expendable supplies available at an authorized dealer.*

How to Read this Manual

Symbols

In this manual, the following symbols are used:

WARNING:

This symbol indicates a potentially hazardous situation that might result in death or serious injury when you misuse the machine without following the instructions under this symbol. Be sure to read the instructions, all of which are described in the Safety Information section.

CAUTION:

This symbol indicates a potentially hazardous situation that might result in minor or moderate injury or property damage that does not involve personal injury when you misuse the machine without following the instructions under this symbol. Be sure to read the instructions, all of which are described in the Safety Information section.

* The statements above are notes for your safety.

Important

If this instruction is not followed, paper might be misfed, originals might be damaged, or data might be lost. Be sure to read this.

Preparation

This symbol indicates the prior knowledge or preparations required before operating.

Note

This symbol indicates precautions for operation, or actions to take after misoperation.

Limitation

This symbol indicates numerical limits, functions that cannot be used together, or conditions in which a particular function cannot be used.

Reference

This symbol indicates a reference.

[]

Keys that appear on the machine's panel display.

【 】

Keys built into the machine's operation panel.

TABLE OF CONTENTS

What You Can do with this Machine (Copy Mode)	2
Machine Types	4
Guide to Components	5
Options	7
Operation Panel	8
Panel Display	11
Displays and Key Operations.....	11

1. Basics





Starting the Machine	13
Turning on the Power.....	13
Turning off the Power.....	14
Changing Modes	15
Originals	16
Sizes and Weights of Recommended Originals.....	16
Sizes Difficult to Detect.....	17
Original Sizes and Scanning Area/Missing Image Area.....	18
Copy Paper	19
Recommended Paper Sizes and Types.....	19
Non-recommended Paper.....	22
Paper Storage.....	22
Toner	23
Handling Toner.....	23
Toner Storage.....	23
Photo Conductor Unit (PCU)	24
Handling Photo Conductor Unit.....	24
Photo Conductor Unit Storage.....	24
Replacing Photo Conductor Unit.....	24

2. Copying

Basic Procedure	25
Setting Originals	27
Setting Originals on the Exposure Glass.....	27
Setting Originals in the Document Feeder.....	27
Setting Non-Mstandard Sized Originals in the Document Feeder.....	29
Basic Functions	30
Adjusting Copy Image Density.....	30
Selecting Your Original Type.....	31
Selecting Copy Paper.....	31
Auto Reduce/Enlarge—Having the Machine Choose the Reproduction Ratios... ..	33

Sort/Stack/Staple	35
Sort—Sorting into Sets (123, 123, 123)	35
Stack—Delivering Copies in Page Batches (111, 222, 333)	37
Staple	38
Copying from the Bypass Tray	41
Program—Storing Your Copy Settings in Memory	45
Storing a Program	45
Deleting a Program	46
Recalling a Program.....	46
Other Functions	47
Energy Saver Mode—Saving Energy	47
Interrupt—Temporarily Stopping One Job to Copy Something Else	47
User Codes	48
Auto Start—Entering Copy Job Settings During the Warm-up Period	48
Original Tone.....	49
How to Set the Papers with Letterhead.....	49
Preset Reduce/Enlarge—Reducing and Enlarging Using Preset Ratios...	50
Zoom—Reducing and Enlarging in 1% Steps	52
Directional Size Magnification (inch)—Stretching and Squeezing the Image into the Copy Area	53
Directional Magnification (%)—Stretching and Squeezing the Image in 1% Steps	55
Center/Border Erase—Erasing the Center and the Border	56
Combine—Combining Originals into One Copy	58
Series Copies—Making One-sided Copies from Various Originals ...	62
Book —Making One-sided Copies from Two Facing Page of a Bound Original (Book).....	62
2-Sided —Making One-sided Copies from Two-sided Originals	63
Duplex—Making Two-Sided Copies	64
1 Sided —Making Two-sided Copies from One-sided Originals	64
2 Sided —Making Two-sided Copies from Two-sided Originals	66
Book —Making Two-Sided Copies from Facing Pages of a Bound Original (Book).....	67
Cover—Adding or Inserting Sheets	68
Front Cover—Copying or Adding a Front Cover	68
Both Covers—Copying or Adding Front and Back Covers	69
OHP Slip Sheet—Copying or Inserting Slip Sheets	70
Positive/Negative—Copying in Complementary Colors	71
Repeat Image—Repeating an Image over the Entire Copy	72
Merging Images (Overlay)—Merging Two Different Originals	73
Preset Stamp—Printing Preset Messages on Your Copies	75
Page Numbering—Printing Page Numbers	78
Combination Chart	80

3. What to do If Something Goes Wrong

If Your Machine does not Operate as You Want.....	83
Message.....	83
Display	84
If You Cannot Make Clear Copies	85
If You Cannot Make Copies as You Want.....	86
Adjust Image	86
Combine	87
Stamp.....	87
Duplex.....	88
 Loading Paper.....	89
Loading Paper in the Large Capacity Tray.....	90
 Changing the Toner Bottle	91
Replacing Photo Conductor Unit (PCU)	93
 Clearing Misfeeds.....	98
Changing the Paper Size	103
Changing the Paper Size in Tray 1 or the Optional Paper Table	103
Changing the Paper Size in Tray 2	105
 Adding Staples	107
 Removing Jammed Staples.....	109

4. User Tools (Copy Features)

Accessing the User Tools (Copy Features)	111
Exiting the User Tools	112
User Tools Menu (Copier Features).....	114
Settings You Can Change with the User Tools	116
1. General Features ¹ / ₄	116
1. General Features ² / ₄	117
1. General Features ³ / ₄	118
1. General Features ⁴ / ₄	119
2. Adjust Image ¹ / ₃	121
2. Adjust Image ² / ₃	122
3. Input/Output ¹ / ₂	124
3. Input/Output ² / ₂	125
4 Stamp Setting ¹ / ₃	125
4 Stamp Setting ² / ₃	126
4 Stamp Setting ³ / ₃	127

5. Remarks

Do's and Don'ts	129
Where to Put Your Machine.....	130
Machine Environment	130
Power Connection.....	131
Access to Machine	131
Maintaining Your Machine	132
Cleaning the Exposure Glass.....	132
Cleaning the Platen Cover	132
Cleaning the Document Feeder	132

6. Specification

Mainframe.....	133
Document Feeder (Option)	137
Paper Tray Unit (Option).....	138
Internal Tray 2 (1bin tray) (Option).....	139
Finisher (Option).....	140
Shift Sort Tray (Option).....	141
Large Capacity Tray (LCT) (Option).....	142
Duplex Unit (Option).....	143
Bypass Tray (Option)	144
48MB Copier Memory Unit (Option).....	145
INDEX.....	146

This page is intentionally blank.

What You Can do with this Machine (Copy Mode)

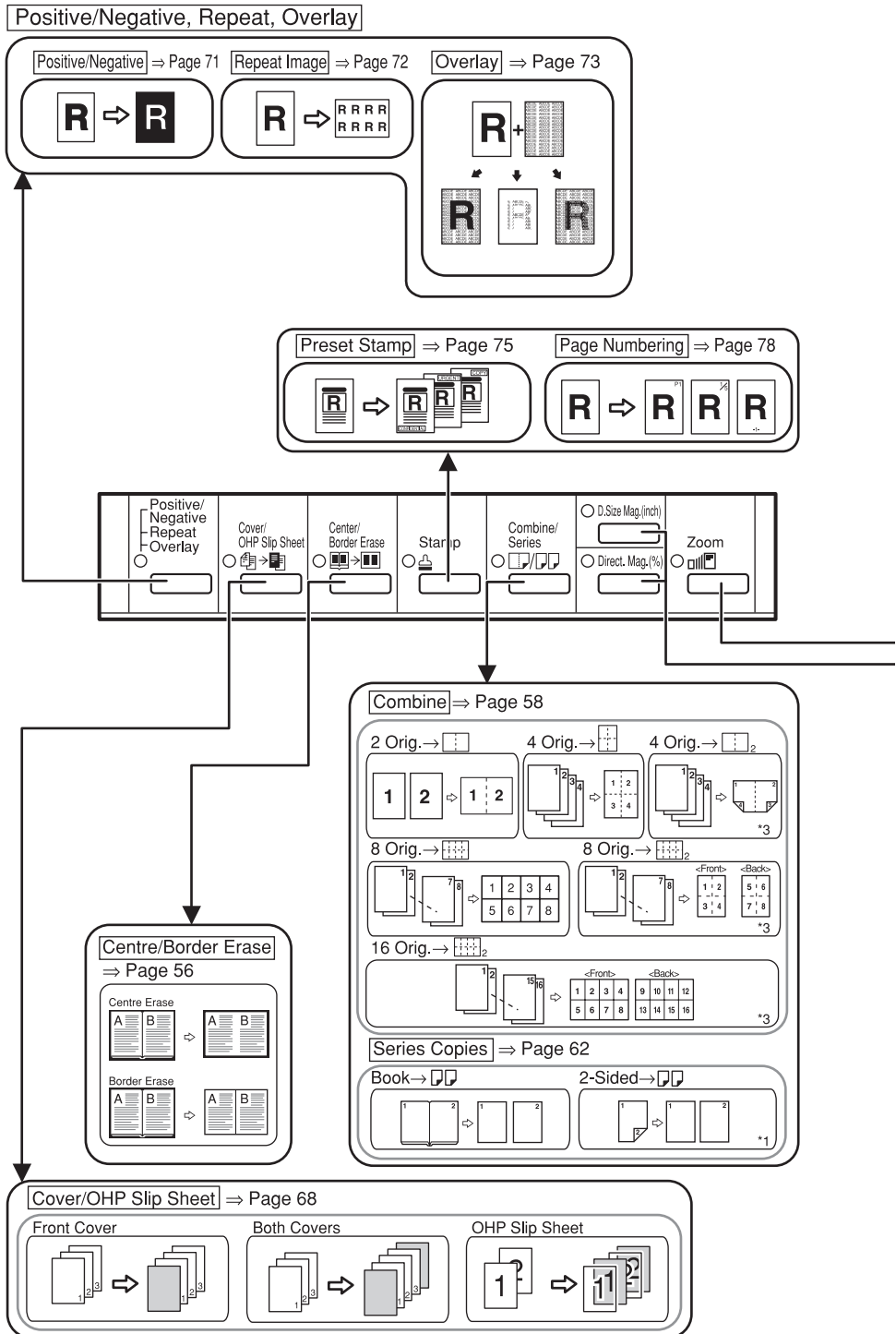

Sort Stack Staple

*1 Optional document feeder is required.
 *2 Optional finisher is required.
 *3 Optional duplex unit is required.

Sort ⇒ Page 36

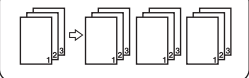

Rotafe Sort ⇒ Page 36

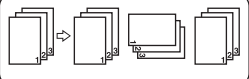

Shift Sort ⇒ Page 36



Stack ⇒ Page 37



Staple ⇒ Page 38



Auto R/E ⇒ Page 33



Zoom ⇒ Page 52



D.Size Mag.(inch) ⇒ Page 53

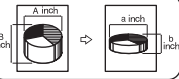

Direct. Mag.(%) ⇒ Page 55

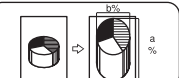
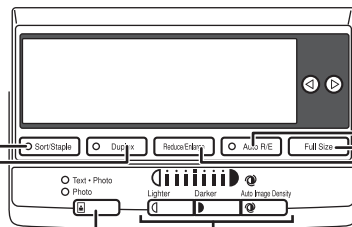
Adjusting Copy Image Density ⇒ Page 30

Selecting Original Type ⇒ Page 31

Reduce/Enlarge ⇒ Page 50



Duplex

1 Sided ⇒ Page 64



*3

2 Sided ⇒ Page 66



*1,*3



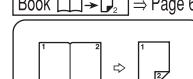

Book ⇒ Page 67



*3

Machine Types

This machine comes in two models which vary in copy speed. To make sure which model you have, see the inside front cover.

	Type 1	Type 2
Copy speed	22 copies/minute (A4  , 8 1/2" x 11" )	27 copies/minute (A4  , 8 1/2" x 11" )
Fax unit	Option	Option
Printer unit	Option	Option

Guide to Components

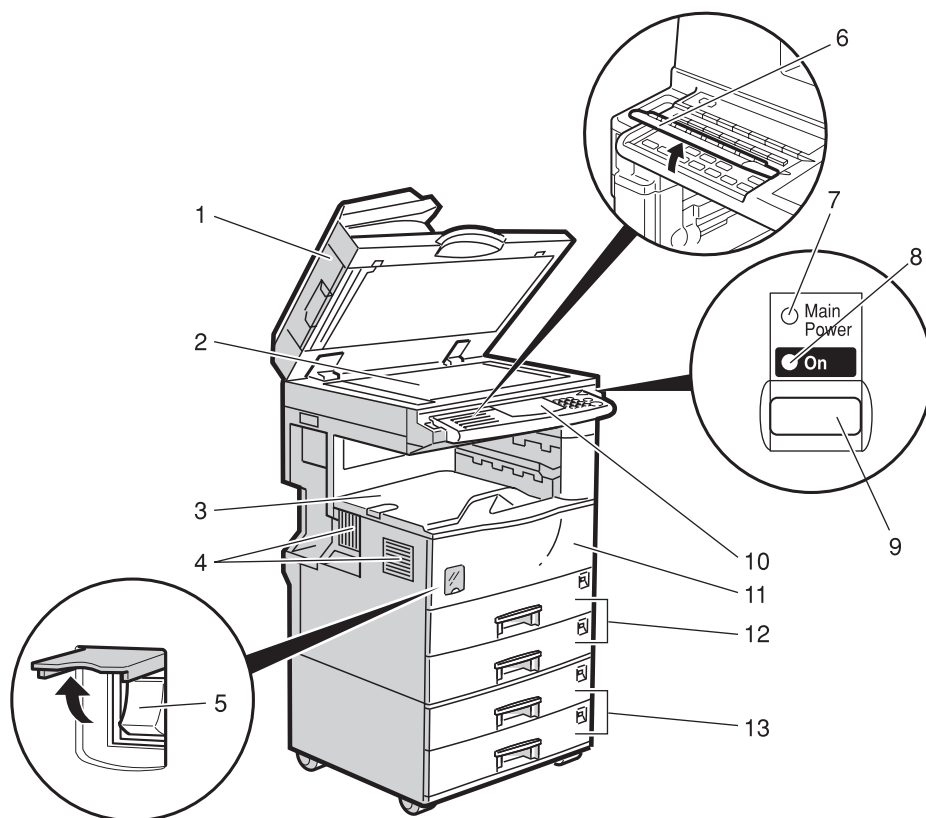

ZAAH200N

1. Platen cover (option) or document feeder (ADF) (option)

Lower the platen cover over originals placed on the exposure glass for copying. If you have the document feeder, insert a stack of originals here. They will be fed automatically.

(The illustration shows the document feeder.)

2. Exposure glass

Position originals here face down for copying. See ⇒ P.16 "Originals".

3. Internal tray

Copied paper is delivered here face down.

4. Ventilation hole

Prevents overheating. Do not obstruct the ventilation hole by placing or leaning an object near it. If the machine overheats, a fault might occur.

5. Main power switch

Press this switch to turn the power on or off.

This switch should only be used by a service representative.

Note

- ❑ If the machine does not operate after turning on the operation switch, check if the main power switch is turned on. If it is off, turn it on.

6. Behind cover

Flip up when you use the keys underneath.

7. Main Power indicator

This indicator lights up when the main power switch is turned on, and goes off when the switch is turned off.

8. On indicator

This indicator lights up when the operation switch is turned on, and goes off when the switch is turned off.

9. Operation switch

Press this switch to turn the power on (the **On** indicator lights up). To turn the power off, press this switch again (the **On** indicator goes off).

10. Operation panel

See ⇒ P.8 “Operation Panel”.

11. Front cover

Open to access the inside of the machine.

12. Paper tray

Set paper here. See ⇒ P.89 “B Loading Paper”.

13. Paper tray unit (option)

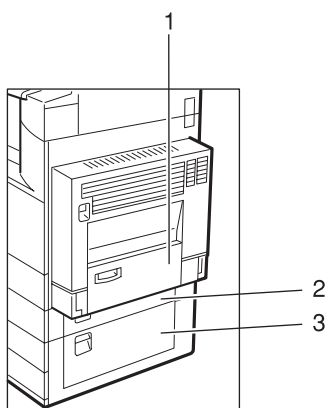

ZAAP040E

1. Bypass tray (option)

Use to copy onto OHP transparencies, adhesive labels, translucent paper, post cards, and non-standard size paper. See ⇒ P.41 “Copying from the Bypass Tray”.

2. Paper tray cover

Open this cover to remove jammed paper fed from the optional paper tray unit.

3. Lower right cover

Open this cover to remove jammed paper.

Options

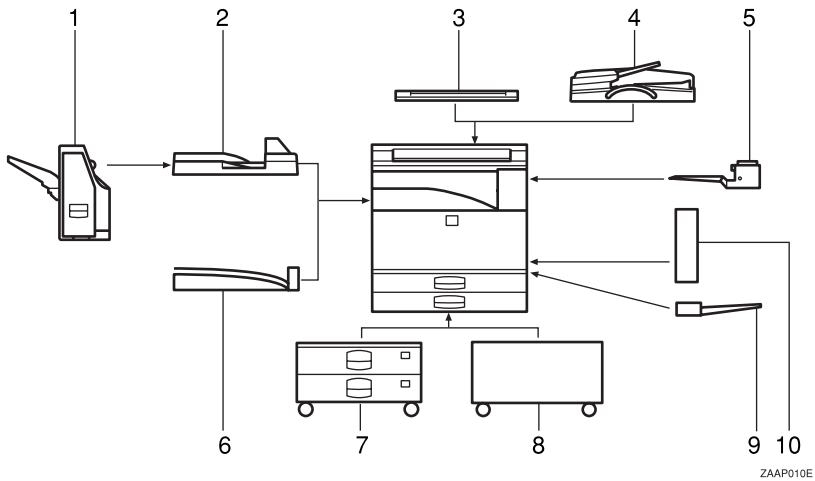

1. Finisher

Sorts, stacks, and staples copies.

2. Bridge unit

Relays copies to the finisher.

3. Platen cover

Lower this cover over originals for copying.

4. Document feeder (ADF)

Insert a stack of originals here.

They will be fed automatically.

5. Internal tray 2 (1 bin tray) (Optional Interchange unit required.)

If you selected this as the output tray, copied paper is delivered here face down. See "15. Output Tray" in the System Settings.

Other options:

- Interchange unit
- 48MB copier memory unit

6. Shift sort tray

Sorts and Stacks copies.

7. Paper tray unit

Consists of two paper trays.

8. Large capacity tray (LCT)

Holds 2,000 sheets of paper.

9. Bypass tray

Use to copy onto OHP transparencies, adhesive labels, translucent paper, post cards, and non-standard size paper. See ⇒ P.41 "Copying from the Bypass Tray".

10. Duplex unit (Optional Interchange unit required.)

Use to make two-sided copies.

Operation Panel

❖ Copier only

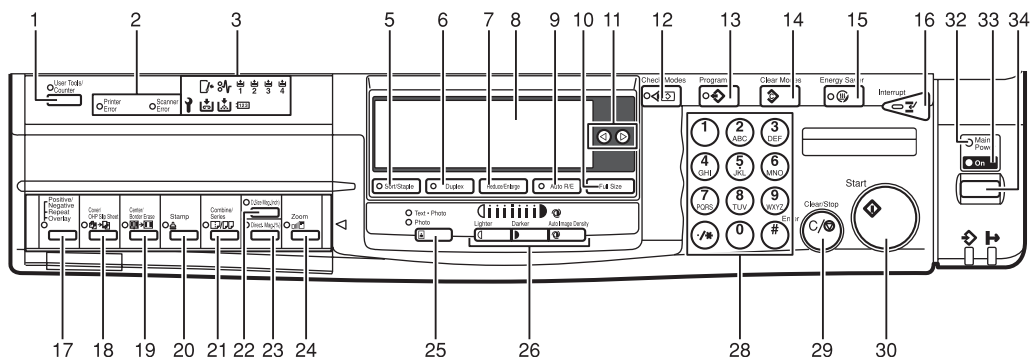

ZAAS100N

❖ Fax or printer installed

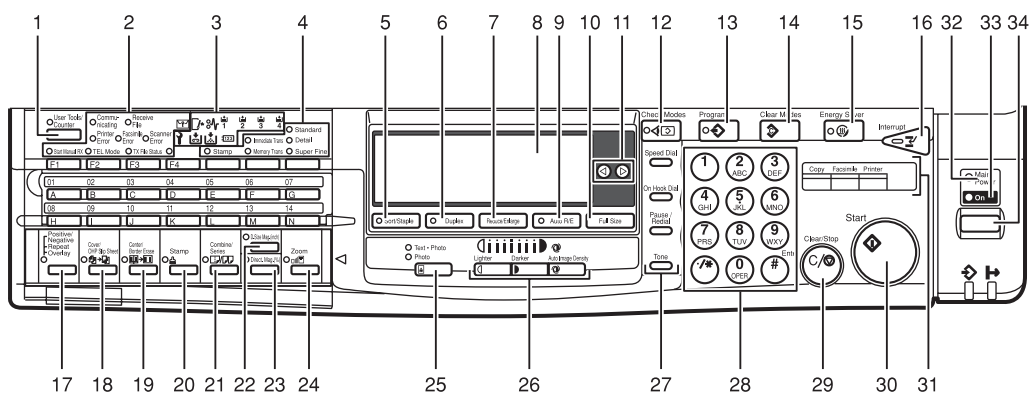

ZAAS012N

1. [User Tools/Counter] key

Press to change the default settings and conditions to meet your requirements. See ⇒ P.111 “User Tools (Copy Features)”.

2. Keys and indicators for fax mode (for machines with the optional fax function)

See the “Fax Reference”.

3. Indicators

These indicators show errors or the status of the machine. See ⇒ P.83 “What to do If Something Goes Wrong”.

4. More indicators for fax mode (for machines with the optional fax function)

See the “Facsimile Reference”.

5. [Sort/Staple] key

Sort/Rotate Sort/Shift Sort: automatically sorts copies.

Shift Stack: stacks together copies of each page.

Staple: staples each set of copies together.

6. [Duplex] key

Makes two-sided copies. See ⇒ P.64 “Duplex—Making Two-Sided Copies”.

7. [Reduce/Enlarge] key

Press to make reduced or enlarged copies. See ⇒ P.50 *“Preset Reduce/Enlarge—Reducing and Enlarging Using Preset Ratios”*.

8. Panel display

Shows operation status, error messages, and function menu. See ⇒ P.11 *“Panel Display”*.

9. [Auto R/E] key

Enlarges or reduces the image automatically according to the specified paper size.

10. [Full Size] key

For making full size copies.

11. ⏪ ⏩ keys (Cursor keys)

Press to select an item on the panel display.

12. [Check Modes] key

Press to check the entered copy job settings.

13. [Program] key

Press to select the program mode. See ⇒ P.45 *“Program—Storing Your Copy Settings in Memory”*.

14. [Clear Modes] key

Press to clear the previously entered copy job settings.

15. [Energy Saver] key

Press to switch to and from Energy Saver mode. See ⇒ P.47 *“Energy Saver Mode—Saving Energy”*.

16. [Interrupt] key

Press to make interrupt copies during a copy run. See ⇒ P.47 *“Interrupt—Temporarily Stopping One Job to Copy Something Else”*.

17. [Positive/Negative], [Repeat], [Overlay] key

- Positive/Negative
Press to make positive/negative copies. See ⇒ P.71 *“Positive/Negative—Copying in Complementary Colors”*.

- Repeat
Press to make repeat copies. See ⇒ P.72 *“Repeat Image—Repeating an Image over the Entire Copy”*.
- Overlay
Press to make overlay image copies. See ⇒ P.73 *“Merging Images (Overlay)—Merging Two Different Originals”*.

18. [Cover/OHP Slip Sheet] key

- Cover
Press to add or insert cover paper. See ⇒ P.68 *“Cover—Adding or Inserting Sheets”*.
- OHP Slip Sheet
Press to make copies or insert slip sheets. See ⇒ P.70 *“OHP Slip Sheet—Copying or Inserting Slip Sheets”*.

19. [Center/Border Erase] key

Press to erase the center and /or all four sides of the original image. See ⇒ P.56 *“Center/Border Erase—Erasing the Center and the Border”*.

20. [Stamp] key

Press to have a stamp mark printed on copies. See ⇒ P.75 *“Preset Stamp—Printing Preset Messages on Your Copies”* and ⇒ P.78 *“Page Numbering—Printing Page Numbers”*.

21. [Combine/Series] key

- Combine
Press to make combine copies. See ⇒ P.58 *“Combine—Combining Originals into One Copy”*.
- Series
Press to make series copies. See ⇒ P.62 *“Series Copies—Making One-sided Copies from Various Originals”*.

22. [D. Size Mag. (inch)] key

Press to make Directional Size Magnification copies. See ⇒ P.53 *“Directional Size Magnification (inch)—Stretching and Squeezing the Image into the Copy Area”*.

23. [Direct. Mag.(%)] key

Press to make Directional Magnification copies. See ⇒ P.55 *“Directional Magnification (%)—Stretching and Squeezing the Image in 1% Steps”*.

24. [Zoom] key

Changes the reproduction ratio in 1% steps.

25. [Original Type] key

Press to select the type of your originals.

26. [Lighter] key and [Darker] keys and [Auto Image Density] key

Adjusts the copy image density.

27. Operation panel for facsimile mode (for machines with the optional fax function)

See the "Facsimile Reference".

28. Number keys

Use to enter the desired number of copies and data for selected modes.

29. [Clear/Stop] key

While entering numbers, press to cancel a number you have entered. While copying, press to stop copying.

30. [Start] key

Press to start copying. Also use to initiate Auto Start. See ⇒ P.48 "*Auto Start—Entering Copy Job Settings During the Warm-up Period*"

31. Function keys (Fax or printer installed machine only)

Press to change modes. To use copy functions, press the [Copy] key.

32. Main Power indicator

This indicator lights up when the main power switch is turned on, and goes off when the main power switch is turned off.

33. On indicator

This indicator lights up when the operation switch is turned on, and goes off when the operation switch is turned off.

34. Operation switch

Press this switch to turn the power on (the **On** indicator lights up). To turn the power off, press this switch again (the **On** indicator goes off).

Panel Display

The panel display shows operational status, error messages, and function menus.

Important

- Do not apply a strong shock or force of about 30N (about 3kgf) or more to the panel display. Otherwise, the display might be damaged.

Note

- Currently selected items are displayed white on black (e. g. **Auto**).
- Keys that are displayed grayed-out (e. g. **OK**) can not be used.
- By default, the machine is in Copy mode when you switch on. This can be changed. See “Settings You Can Change With The User Tools” of the System Settings.

Displays and Key Operations

❖ Copy display

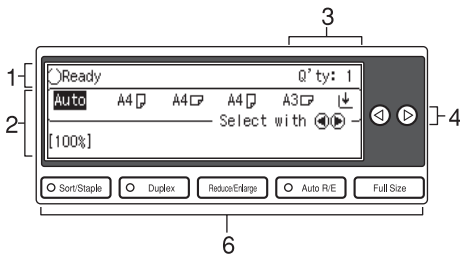

ZAAX030N

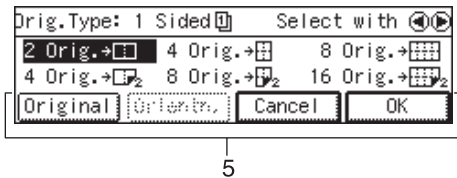

ZAAX150E

- The machine status and messages appear here.
- Items which can be selected or specified.
- Number of copies set.

- Press these keys to select an item.
- Settings for this function.
- Press these keys to select or confirm settings.

❖ Common keys

[OK]	Sets a selected function or entered value and returns to the previous display.
[Cancel]	Cancels a selected function or entered value and returns to the previous display.
[↑Prev.] [↓Next]	When there are too many items fit on the display, use these keys to move between pages.
⏪ ⏩	Press to highlight the selection you wish to select.
[PrevMenu]	Press to return to the previous menu.
[Exit]	Sets a selected function or entered value and returns to the initial display.

Starting the Machine

To start the machine, turn on the main power switch (copier only) or the operation switch (fax or printer installed machine).

Note

- ❑ This machine automatically enters Energy Saver mode or turns itself off if you do not use the machine for a while. See “07. Energy Saver Level”, “06. Panel Off Timer”, “09. Auto Off Timer” in the System Settings Reference.

💡 Power switches for fax or printer installed machine

This machine has two power switches: See ⇒ P.5 “Guide to Components”.

❖ Operation switch (right side of the operation panel)

Turn on this switch to activate the machine. When the machine has warmed up, you can make copies or send faxes.

❖ Main power switch (front of the machine)

Do not touch the main power switch. It should be used only by a service representative when the optional fax unit is installed.

⚠ Important

- ❑ If you leave the main power switch off for more than about one hour, all fax files in memory will be lost. See “Turning off the Power” in the Facsimile Reference.

Turning on the Power

Starting the Machine

- 1 Make sure that the power cord is plugged into the wall outlet firmly.
- 2 Open the switch cover and turn on the main power switch.

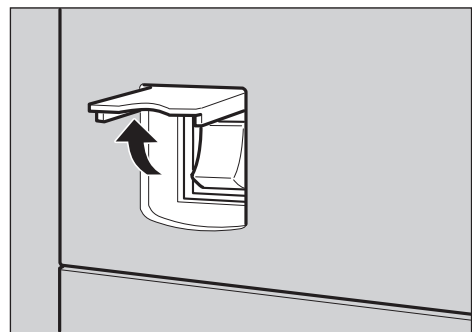

ZAAH270E

- 3 If the On indicator goes off, press the operation switch to make the On indicator light up.

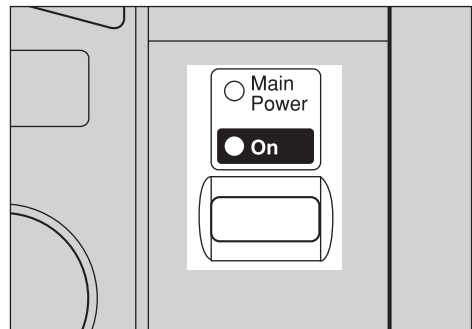

ZAAH202N

The panel display will come on.

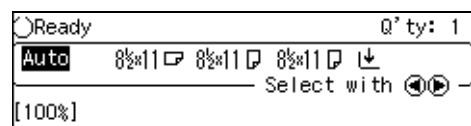

Note

- If the power is not turned on when the operation switch is pressed, check if the main power switch is on. If off, turn it on.
- During the warm-up period, you can use the Auto Start function. See ⇒ P.48 “Auto Start—Entering Copy Job Settings During the Warm-up Period”.
- Warm-up period is 45 seconds.

When the machine is set for user codes

- 1** Enter your user code using the Number keys. Then press the **【#】** key.

Note

- To prevent others from making copies with your user code, press the **【Clear Modes】** key and the **【Clear/Stop】** key simultaneously after copying.

Reference

For how to set user codes, see ⇒ P.119 “1. General Features 4/4”.

When the **【Energy Saver】 indicator is lit**

The machine is in Energy Saver mode.

- 1** Press the **【Energy Saver】** key.

The machine will return to the ready condition.

Note

- The machine will also return to the ready condition when an original is set in the document feeder, or when the platen cover or document feeder is opened.

Reference

See “06. Panel Off Timer” in the System Settings Reference.

Turning off the Power**Important**

- If you wish to unplug the power cord or turn off the main power switch, make sure that the remaining memory space indicates 100% on the display for fax mode.
- Fax files stored in memory will be lost an hour after you turn the main power switch off or you unplug the power cord. See “Turning off the Power” in the Fax Reference.

- 1** Press the operation switch to make the On indicator go off.

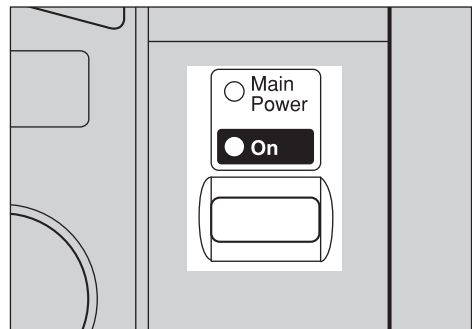

Changing Modes

You can use this machine not only as a copier, but optionally as a fax machine or a printer as well. Press the **[Copy]** key to use copy functions, or press the **[Facsimile]** key to use facsimile functions.

If the display shows a mode other than copy mode, press the **[Copy]** key to switch to copy mode.

For how to change the mode the machine starts in when you turn the operation switch on, see "01. Function Priority" in the System Settings Reference.

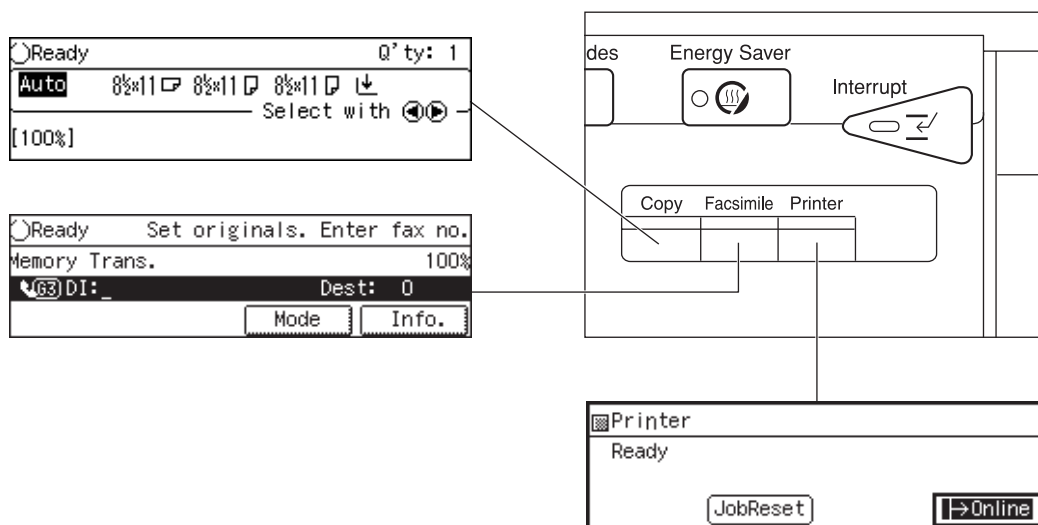

ZAAX040N

Limitation

- ❑ You cannot switch modes in any of the following cases:
 - When scanning in a fax message for transmission.
 - During immediate transmission.
 - When accessing the user tools.
 - During interrupt copying.
 - During on hook dialing for fax transmission.
 - During Energy Saver mode.
 - When the fax handset is lifted.
 - While scanning in a document with the scan feature.

Originals

1

Sizes and Weights of Recommended Originals

❖ Metric version

Where original is set	Original Size	Original Weight
Exposure glass	Up to A3	--
Document feeder	1-sided originals: A3☐ – A5☐☐	40 – 128g/m ²
	2-sided originals: A3☐ – A5☐☐	52 – 105g/m ²

❖ Inch version

Where original is set	Original Size	Original Weight
Exposure glass	Up to 11" × 17"	--
	1-sided originals: 11" × 17"☐ – 5½" × 8½"☐☐	11 – 34 lb
	2-sided originals: 11" × 17"☐ – 5½" × 8½"☐☐	14 – 28 lb

Non-recommended originals for the document feeder

Setting the following originals in the document feeder might cause paper mis-feeds or damage to the originals. Set these originals on the exposure glass.

- Originals other than those specified in ⇒ P.16 “*Sizes and Weights of Recommended Originals*”
- Stapled or clipped originals
- Perforated or torn originals
- Curled, folded, or creased originals
- Pasted originals
- Originals with any kind of coating, such as thermal fax paper, art paper, aluminum foil, carbon paper, or conductive paper
- Originals with indexes, tags, or other projecting parts
- Sticky originals such as translucent paper
- Thin originals that have low stiffness
- Originals of inappropriate weight ⇒ P.16 “*Sizes and Weights of Recommended Originals*”
- Bound originals such as books
- Transparent originals such as OHP transparencies or translucent paper

Sizes Difficult to Detect

It is difficult for the machine to detect the sizes of the following originals, so select the paper size manually.

- Originals with indexes, tags, or other projecting parts
- Transparent originals such as OHP transparencies or translucent paper
- Dark originals with many letters and drawings
- Originals which partially contain solid images
- Originals which have solid images at their edges
- Originals other than those (marked by ○) in the table below. See ⇒ P.17 "Sizes detectable by the Auto Paper Select".

Sizes detectable by the Auto Paper Select

❖ Metric version

Size	A3	B4	A4	B5	A5	11" × 17"	8 ¹ / ₂ " × 14"	8 ¹ / ₂ " × 11"	5 ¹ / ₂ " × 8 ¹ / ₂ "	8 ¹ / ₂ " × 13"
Where setting original	☐	JIS ☐	☐	JIS ☐	☐		☐	☐☐	☐☐	☐
Exposure glass	○	○	○	○	×	×	○	×	×	○
Document feeder	○	○	○	○	○	×	×	×	×	○

❖ Inch version

Size	A3	B4	A4	B5	A5	11" × 17"	8 ¹ / ₂ " × 14"	8 ¹ / ₂ " × 11"	5 ¹ / ₂ " × 8 ¹ / ₂ "	8 ¹ / ₂ " × 13"	10" × 8"	10" × 14"
Where setting original	☐	JIS ☐	☐	JIS ☐	☐	☐	☐	☐☐	☐☐	☐	☐	☐
Exposure glass	×	×	×	×	×	○	○	○	×	○	○	○
Document feeder	×	×	×	×	×	○	○	○	○	×	×	○

Original Sizes and Scanning Area/Missing Image Area

❖ Exposure glass

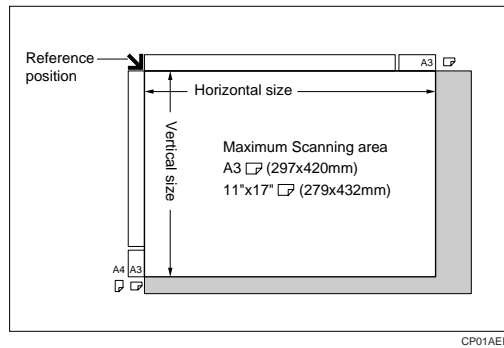

❖ Document feeder

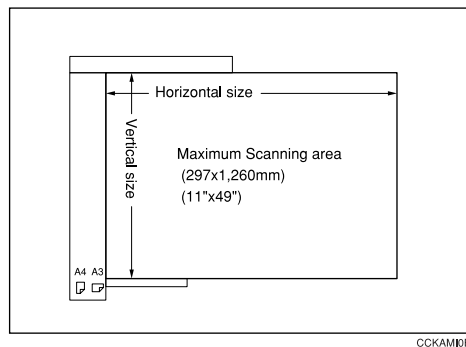

! Limitation

- ❑ Even if you correctly set originals in the document feeder or on the exposure glass, 3mm, 0.1" margins on all four sides might not be copied.

Copy Paper



Recommended Paper Sizes and Types

1

The following limitations apply to each tray:

		Metric version	Inch version	Paper weight	Paper capacity
Tray 1	Paper tray unit (option)	A3, B4JIS, A4, B5JIS, A5, 11" x 17", 8 1/2" x 14", 8 1/2" x 11", 5 1/2" x 8 1/2", 7 1/4" x 10 1/2", 8" x 13", 8 1/2" x 13", 8 1/4" x 13", 8" x 10", 10" x 14"		60 – 105g/m ² , 16 – 28 lb	500 sheets *1
		<p> Note</p> <p><input type="checkbox"/> You have to specify the paper size with the user tools. See => P.103 "Changing the Paper Size".</p>			
Tray 2		A3, B4JIS, A4, B5JIS, A5, B6JIS *2, A6, 3 7/8" x 7 1/2", 4 1/8" x 9 1/2", 11" x 17", 8 1/2" x 14", 8 1/2" x 11", 8 1/2" x 5 1/2", 10 1/2" x 7 1/4", 8" x 13", 8 1/2" x 13", 8 1/4" x 13", 8" x 10", 10" x 14", 8K *3, 16K *4, C5 Env., C6 Env., DL Env.		60 – 105g/m ² , 16 – 28 lb	500 sheets *1
	<p> Note</p> <p><input type="checkbox"/> You have to specify the paper size with the user tools. See => P.103 "Changing the Paper Size".</p>				
Tray 2	Non-standard sizes	A3, B4JIS, A4, B5JIS, A5, B6, A6, 11" x 17", 8 1/2" x 14", 8 1/2" x 11", 8 1/2" x 5 1/2", 10 1/2" x 7 1/4", 8" x 13", 8 1/2" x 13", 8 1/4" x 13", 8" x 10"		60 – 157g/m ² , 16 – 42 lb	*5
		Translucent paper (A3, B4JIS, A4, B5JIS)			
		OHP transparencies (A4)			
		Adhesive labels (B4JIS, A4)			

		Metric version	Inch version	Paper weight	Paper capacity
By-pass tray (option)	Standard Sizes	A3☐, B4JIS☐		60 – 105g/m ² , 16 – 28 lb	10 sheets *1
		A4☐☐, B5JIS☐☐, A5☐, B6JIS☐	A4☐☐, B5JIS☐☐, A5☐, B6JIS☐		100 sheets *1
		*2 A6☐, 11" × 17"☐, 8 ¹ / ₂ " × 14"☐, 8 ¹ / ₂ " × 11"☐☐, 8 ¹ / ₂ " × 5 ¹ / ₂ "☐, 10 ¹ / ₂ " × 7 ¹ / ₄ "☐☐, 8" × 13"(F)☐, 8 ¹ / ₂ " × 13"(F4)☐, 8 ¹ / ₄ " × 13"☐, 8" × 10"☐☐, 10" × 14"☐	*2 A6☐, 11" × 17"☐, 8 ¹ / ₂ " × 14"☐, 8 ¹ / ₂ " × 11"☐☐, 8 ¹ / ₂ " × 5 ¹ / ₂ "☐, 10 ¹ / ₂ " × 7 ¹ / ₄ "☐☐, 8" × 13"(F)☐, 8 ¹ / ₂ " × 13"(F4)☐, 8 ¹ / ₄ " × 13"☐, 8" × 10"☐☐, 10" × 14"☐, 3 ⁷ / ₈ " × 7 ¹ / ₂ "☐, 4 ¹ / ₈ " × 9 ¹ / ₂ "☐, C5 Env.☐, C6 Env.☐, DL Env.☐		
		*2 11" × 15"☐, 11" × 14"☐, 10" × 15"☐, 8 ¹ / ₄ " × 14"☐, 8" × 10 ¹ / ₂ "☐☐	*2 11" × 15"☐, 11" × 14"☐, 10" × 15"☐, 8 ¹ / ₄ " × 14"☐, 8" × 10 ¹ / ₂ "☐☐		
		A3☐, B4JIS☐			60 – 157g/m ² , 16 – 42 lb
	A4☐☐, B5JIS☐☐, A5☐, B6JIS☐		40 sheets *1		
	A6☐, 11" × 17"☐, 8 ¹ / ₂ " × 14"☐, 8 ¹ / ₂ " × 11"☐☐, 8 ¹ / ₂ " × 5 ¹ / ₂ "☐, 10 ¹ / ₂ " × 7 ¹ / ₄ "☐☐, 8" × 13"☐, 8 ¹ / ₂ " × 13"☐, 8 ¹ / ₄ " × 13"☐, 8" × 10"☐ Note ☐ You have to specify the paper size with the user tools. See ⇒ P.103 "Changing the Paper Size".				
	Non-standard sizes *6	Translucent paper (A3☐, B4JIS☐), OHP transparencies			10 sheets *1
		Translucent paper (A4☐☐, B5JIS☐☐), postcards			40 sheets *1
		Adhesive labels (B4JIS☐, A4☐)			1 sheets *1

	Metric version	Inch version	Paper weight	Paper capacity
Large capacity tray (option)	A4 	8 ¹ / ₂ " × 11" 	60 – 105g/m ² , 16 – 28 lb	2,000 sheets ^{*1}

^{*1} Paper weight: 20 lb, 64g/m²

^{*2} When you set non-standard size paper in the bypass tray, you have to specify the size. See ⇒ P.41 “Copying from the Bypass Tray”.

^{*3} 8K(Ba-Kai) = 267 × 390 mm, 10.6" × 15.4"

^{*4} 16K(Shi-Lui-Kai) = 195 × 267 mm, 7.7" × 10.6"

^{*5} Do not stack copy paper above the Tray 2 lower limit mark. See ⇒ P.105 “Changing the Paper Size in Tray 2”.

^{*6} Always set one sheet at a time. See ⇒ P.41 “Copying from the Bypass Tray”.

Important

- If you use damp or curled paper, a misfeed might occur. In such a case, try turning over the paper stack in the paper tray. If there is no improvement, change to copy paper with less curl.

Note

- When you use the bypass tray, it is recommended to set the copy paper direction to .
- When you use the color paper, set it in the tray 2. Do not stack the paper above the lower limit mark of the tray 2.
- Postcards should be fed from the bypass tray.
- If you load paper of the same size and in the same direction in two or more trays, the machine automatically shifts to another tray when the tray in use runs out of paper. This function is called Auto Tray Switch. (If you put recycled paper in paper trays using the Special Paper Indicate menu, this function is not available with these trays unless their settings are identical.) This saves interrupting a copy run to replenish paper even when you make a large number of copies. You can cancel this setting. See “13. Auto Tray Switch” and “14. Special Pap. Indict” of the System Settings.

Reference

If you want to add paper, see ⇒ P.89 “B Loading Paper”.

If you want to change the paper size, see ⇒ P.103 “Changing the Paper Size”.

Non-recommended Paper

 **CAUTION:**

- *Do not use aluminum foil, carbon paper, or similar conductive paper to avoid a fire or equipment failure.*

 **Important**

- Do not use paper with any kind of coating such as:
 - Thermal fax paper
 - Art paper
 - Aluminum foil
 - Carbon paper
 - Conductive paper
- Otherwise, a fault might occur.
- Do not use copy paper that has been already copied on. Otherwise, a fault might occur.

 **Note**

- Do not use the following type of paper because a paper misfeed might occur.
 - Bent, folded, or creased paper
 - Torn paper
 - Slippery paper
 - Perforated paper
 - Rough paper
 - Thin paper that has low stiffness
 - Paper with much paper dust on its surface
- If you make copies on rough grain paper, the copy image might be blurred.
- Do not use paper which has been copied or printed on.

Paper Storage

 **Note**

- When storing paper, the following precautions should always be followed:
 - Do not store paper where it will be exposed to direct sunlight.
 - Avoid storing paper in humid areas (humidity: 70% or less).
 - Store on a flat surface.
- Keep open reams of papers in the package, and store as you would unopened paper.
- Under high temperature and high humidity, or low temperature and low humidity conditions, store papers in a vinyl bag.

Toner

Handling Toner

 **WARNING:**

- *Do not incinerate used toner or toner containers. Toner dust might ignite when exposed to an open flame. Dispose of used toner containers in accordance with local regulations for plastics.*

 **CAUTION:**

- *Keep toner (used or unused) and toner containers out of reach of children.*

 **CAUTION:**

- *Our products are engineered to meet high standards of quality and functionality, and we recommend that you only use the expendable supplies available at an authorized dealer.*

 **Important**

- If you use toner other than that recommended, a fault might occur.

 **Reference**

If you want to add toner, see ⇒ P.91 “D Changing the Toner Bottle”.

Toner Storage

 **Note**

- When storing toner, the following precautions should always be followed:
 - Store toner containers in a cool, dry place free from direct sunlight.
 - Do not store toner where it will be exposed to heat.
 - Do not eat or swallow toner, and keep it out of reach of children.
 - Store on a flat surface.

Photo Conductor Unit (PCU)

1

Handling Photo Conductor Unit

 **WARNING:**

- *Do not incinerate the photoconductor unit. Toner dust might ignite when exposed to an open flame. Dispose of the used photoconductor unit in accordance with local regulations for plastics.*

Photo Conductor Unit Storage

 **CAUTION:**

- *Our products are engineered to meet high standards of quality and functionality, and we recommend that you only use the expendable supplies available at an authorized dealer.*

 **Note**

- When storing photo conductor units, the following precautions should always be followed:
 - Store PCU in a cool, dark place free from direct sunlight.
 - Do not store PCU in a wet place.
 - Follow the instructions on the carton box of PCU

Replacing Photo Conductor Unit

 **Reference**

See ⇒ P.93 “Replacing Photo Conductor Unit (PCU)”

2. Copying

Basic Procedure

- 1 When the machine is set for user codes, enter the user code with the Number keys and then press the **[#]** key.

Reference

See ⇒ P.48 “User Codes”.

- 2 Make sure that the machine is in Copy mode.

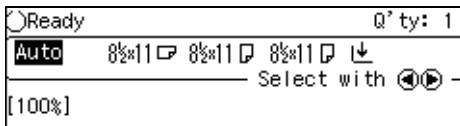

Note

- If not, press the **[Copy]** key.

- 3 Make sure that there are no previous settings remaining.

Note

- To clear settings, press the **[Clear Modes]** key.

- 4 Set your originals.

Reference

See ⇒ P.27 “Setting Originals”.

- 5 Set your desired settings.

- 6 Enter the number of copies required with the Number keys.

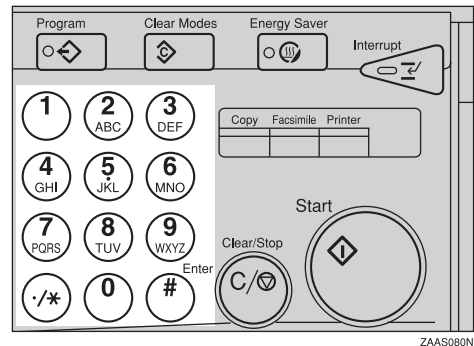

Note

- The maximum copy quantity can be set between 1 and 99 (default: 99). See “05. Max. Copy Q'ty” in ⇒ P.117 “1. General Features 2/4”.
- To change the number entered, press the **[Clear/Stop]** key and enter the new number.

- 7 Press the **[Start]** key.

The machine starts copying.

Note

- To stop the machine during the multi-copy run, press the **[Clear/Stop]** key.
- To return the machine to the initial condition after copying, press the **[Clear Modes]** key.

 **System Reset**

The machine returns to its initial condition automatically after your job is finished, after a certain period of time. This function is called “System Reset”.

 **Note**

- You can change the System Reset time. See “04. System Reset” in the System Settings Reference.

 **Auto Off**

The machine turns itself off automatically after your job is finished, after a certain period of time. This function is called “Auto Off”.

 **Note**

- How to exit Auto Off mode depends on your machine configuration:
 - Press the operation switch
- You can change the Auto Off time. See “09. Auto Off Timer” in the System Settings.
- You can change the default settings for basic functions. See ⇒ P.116 “*Settings You Can Change with the User Tools*” and “*User Tools (System Settings)*” in the System Settings Reference.

Setting Originals

Note

- Basically the originals should be aligned to the rear left corner. However, some copy functions may produce different results depending on the direction of the originals. For details, see explanations of each function.

Originals	Set in the document feeder	Set on the exposure glass
	<small>set11EE</small>	
	<small>set22EE</small>	

Reference

See ⇒ P.16 "Originals".

Setting Originals on the Exposure Glass

- 1** Lift the platen cover or the document feeder.

Note

- Be sure to open the platen cover or the document feeder by more than 30°, otherwise the original size might not be detected correctly.

- 2** Set the original face down on the exposure glass. The original should be aligned to the rear left corner.

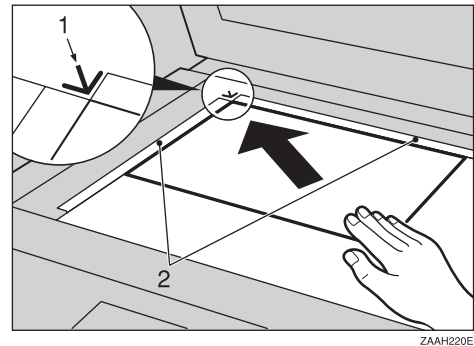

1: Reference mark

2: Scale

- 3** Lower the platen cover or the document feeder.

Setting Originals in the Document Feeder

Note

- The original might become dirty if it is written with a pencil or similar tools.
- You cannot set a multi-page original with pages of different sizes in the document feeder. If your original contains pages of different sizes, use the SADF function and set each page one at a time. Alternatively, set pages one at a time on the exposure glass.
- Do not place any foreign objects on the document feeder or cover it with your hand. This could cause the size not to be detected properly.

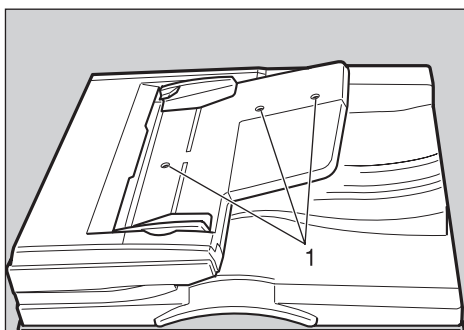

ZAAH280E

1: Sensor

Reference

Regarding originals that the document feeder can handle, see ⇒ P.16 “Originals”.

Setting a stack of originals in the document feeder

- 1** Adjust the guide to the original size.
- 2** Set the aligned originals face up into the document feeder.

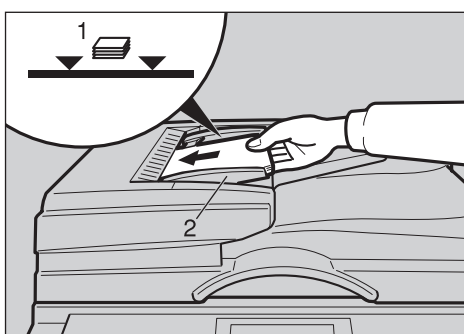

ZAAH040E

- 1: Limit mark
- 2: Document guide

Note

- Do not stack originals above the limit mark.
- To avoid a multi-sheet feed, shuffle the originals before setting them in the document feeder.

When SADF mode is selected

- 1** Set one original face up into the document feeder. Then press the **[Start]** key.

The Auto Feed indicator is shown on the display.

- 2** When the machine instructs you to set another original, set the next page.

The second and subsequent originals can be fed automatically without pressing the **[Start]** key.

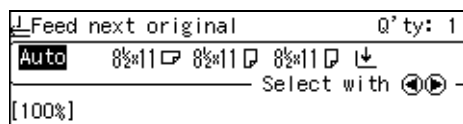









Note

- You can adjust the time the machine waits before being ready for the next original. See “04. SADF Auto Reset” in ⇒ P.124 “3. Input/Output 1/2”.

Setting Non-Standard Sized Originals in the Document Feeder

Limitation

- Enter the size of your original if it is not one of the following: A3 , B4JIS , A4 , B5JIS , A5 , 11" × 17" , 8¹/₂" × 14" , 8¹/₂" × 11" , 5¹/₂" × 8¹/₂" 
- The paper size that can be set with this function is vertical 105–297mm (4" × 11"), horizontal 128–1,260mm (5" × 49").
- The maximum copy paper size is 297 × 432mm (11" × 17").
- You cannot use the Auto Paper Select function with this function.

1 Set one original face up into the document feeder.

2 Press the  key to select your desired paper tray or bypass tray.

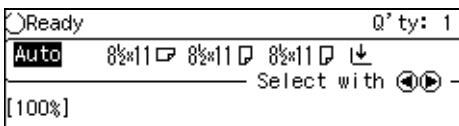

3 Press the **[#]** key.

Note

- When you select the paper tray, go to step **5**.

4 If you select the bypass tray in step **2**, press the **[Orig. Size]** key.

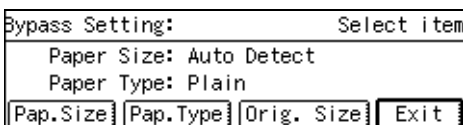

5 Enter the horizontal size of the original with the Number keys, then press the **[#]** key.



6 Enter the vertical size of the original with the Number keys, then press the **[OK]** key.

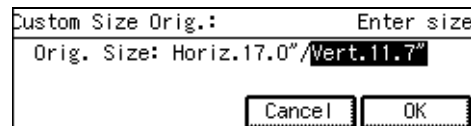

7 Press the **[Start]** key.

Basic Functions

The following basic functions are explained in this section.

- ❖ **Adjusting Copy Image Density**
Auto and Manual Image Density
- ❖ **Selecting the Original Type**
Text, Text-Photo, Photo
- ❖ **Selecting the Copy Paper**
Auto Paper Select and Manual Paper Select
- ❖ **Auto Reduce/Enlarge**
The machine can choose an appropriate reproduction ratio based on the paper and original sizes you select.

Note

- You can select functions to be activated when System Reset is turned on, when Energy Saver is turned off, or after the machine is powered on. See ⇒ P.116 “1. General Features 1/4”.
- You can change default settings for basic functions. See ⇒ P.116 “Settings You Can Change with the User Tools”.

Adjusting Copy Image Density

You can adjust the copy image density to match your originals.

There are three ways to specify image density:

- ❖ **Auto Image Density**
The machine automatically adjusts the image density.

- ❖ **Manual Image Density**
If you require darker or lighter copies, adjust the image density yourself.

- ❖ **Combined Auto and Manual Image Density**
Use when copying originals with a dirty background (such as newspapers). You can adjust the foreground density while leaving the background unchanged.

Reference

You can change the density level with the user tools. See “10. Text Density” in ⇒ P.118 “1. General Features 3/4”.

- 1** Select one of the Image Density modes.

Auto Image Density

- 1** Make sure that the Auto Image Density indicator is lit.

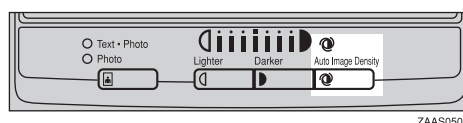

ZAAS050N

Note

- If it is not, press the **[Auto Image Density]** key.

Manual Image Density

- 1** Press the **[Auto Image Density]** key so the indicator goes out.

- ② Press the **[Lighter]** or **[Darker]** key to adjust the image density.

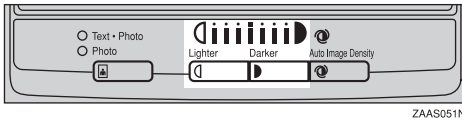

ZAAS051N

Combined Auto and Manual Image Density

- ① Make sure that the Auto Image Density indicator is lit.
- ② Press the **[Lighter]** or **[Darker]** key to adjust the density.

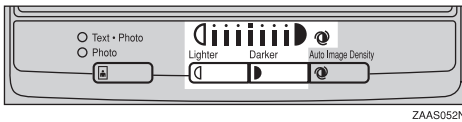

ZAAS052N

Selecting Your Original Type

Select one of the following types to match your originals:

❖ **Text**

If you do not select any mode, your originals will be scanned with the settings suitable for text originals (Text mode).

❖ **Text-Photo**

Select Text-Photo when your originals contains photographs or pictures with letters.

❖ **Photo**

Delicate tones of photographs and pictures can be reproduced with this mode.

- ① Press the **[Original Type]** key and select the original type.

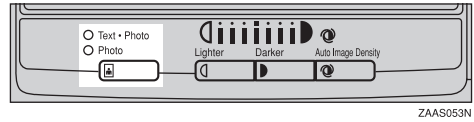

ZAAS053N

Note

- ❑ Press the **[Original Type]** key to step through the following types:

No indicator lit	Text
Upper indicator lit	Text-Photo
Lower indicator lit	Photo

Selecting Copy Paper

There are two ways to select copy paper:

❖ **Auto Paper Select**

The machine selects a suitable size of copy paper automatically based on the original size and the reproduction ratio.

Note

- ❑ When the original is set at a different direction from the copy paper in the paper tray the machine automatically rotates the original image by 90° to match the copy paper direction. This applies to the following paper sizes:

Metric version	A4 , B5JIS
Inch version	8 ¹ / ₂ " × 11" , 5 ¹ / ₂ " × 8 ¹ / ₂ " (document feeder)

❖ **Manual Paper Select**

You can select the desired copy paper size manually. You can also select the bypass tray.















 **Reference**

See ⇒ P.41 “Copying from the Bypass Tray”.















 **Note**

- ❑ When you use Auto Paper Select, refer to the following table for possible copy paper sizes and directions (if the ratio is 100%).

❖ **Metric version**

Where original is set	Paper size and direction
Exposure glass	A3  , B4JIS  , A4  B5JIS   , 8 1/2" × 13"  , 8 1/2" × 14" 
Document feeder	A3  , B4JIS  , A4  B5JIS   , A5  × 13" 

❖ **Inch version**

Where original is set	Paper size and direction
Exposure glass	11" × 17"  , 8 1/2" × 14"  , 8 1/2" × 11"   , 8 1/2" × 13"   , 10" × 14"  , 8" × 10" 
Document feeder	11" × 17"  , 8 1/2" × 14"  , 8 1/2" × 11"   , 5 1/2" × 8 1/2"  

- ❑ For some originals, the original size might not be detected correctly. See ⇒ P.17 “Sizes Difficult to Detect”.

- ❑ When you set special paper in the paper tray, you can have the kind of paper shown on the display. See “14. Special Pap. Indict” of the System Settings.
- ❑ If a paper tray has been specified as containing special paper, Auto Paper Select cannot use it. See “14. Special Pap. Indict”.
- ❑ If you specify all papers trays as containing special paper you cannot use Auto Paper Select.
- ❑ If you set the all paper tray to special paper, you cannot use the Auto Paper Select function.

1 Select the copy paper.

Auto Paper Select

- 1** Make sure that Auto (Auto Paper Select) is selected.

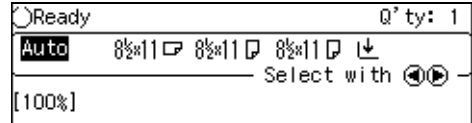

Manual Paper Select

- 1** Select the paper tray or bypass tray by pressing the   keys.

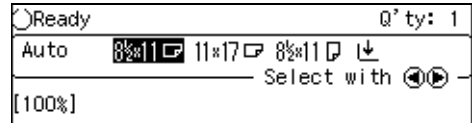

💡 Rotate Copy

If the direction in which your original is set (landscape or portrait) is different from the paper you are copying onto, this function rotates the original image by 90° and fits it on the copy paper. This function works when Auto Paper Select or Auto Reduce/Enlarge are selected. See “Auto Paper Select” in ⇒ P.31 “Selecting Copy Paper” and ⇒ P.33 “Auto Reduce/Enlarge—Having the Machine Choose the Reproduction Ratios”.

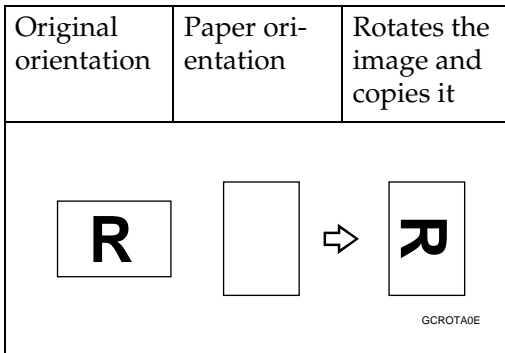

⚠️ Limitation

- ❑ You cannot use the Rotated Copy function when enlarging onto B4JIS or A3 size paper. In this case, set your original in the landscape direction.

	You cannot rotate:	However, you can rotate:
Original Size and Direction	A4, B5JIS, or A5 portrait	A4, B5JIS, or A5 landscape
	↓ when enlarging to	↓ when enlarging to

Copy paper Size and Direction	B4JIS, A3	B4JIS, A3

- ❑ You cannot use the Rotated Copy function when Staple function is selected. See ⇒ P.38 “Staple”.

Auto Reduce/Enlarge—Having the Machine Choose the Reproduction Ratios

The machine can choose an appropriate reproduction ratio based on the paper and original sizes you select.

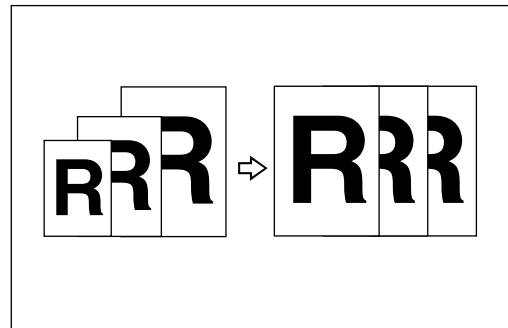

⚠️ Limitation

- ❑ You cannot use the bypass tray with this function.

📝 Note

- ❑ When you use Auto Reduce/Enlarge, refer to the following table for possible original sizes and directions:

❖ Metric version

Where original is set	Original size and direction
Exposure glass	A3 ☐, B4JIS ☐, A4 ☐☐, B5JIS ☐☐, 8 ¹ / ₂ " × 13" ☐, 8 ¹ / ₂ " × 14" ☐
Document feeder	A3 ☐, B4JIS ☐, A4 ☐☐, B5JIS ☐☐, A5 ☐☐, 8 ¹ / ₂ " × 13" ☐

❖ Inch version

Where original is set	Original size and direction
Exposure glass	11" × 17" ☐, 8 ¹ / ₂ " × 14" ☐, 8 ¹ / ₂ " × 11" ☐☐, 8 ¹ / ₂ " × 13" ☐
Document feeder	11" × 17" ☐, 8 ¹ / ₂ " × 14" ☐, 8 ¹ / ₂ " × 11" ☐☐, 5 ¹ / ₂ " × 8 ¹ / ₂ " ☐☐

- ☐ The machine will choose a reproduction ratio in the range 25–400 %.
- ☐ When you set the originals in the document feeder, you can change the reproduction ratio from 50–200 %.
- ☐ For some originals, the original size might not be detected correctly. See ⇒ P.17 “*Sizes Difficult to Detect*”.

1 Press the [Auto R/E] key.



ZAAS073N

2 Select the paper tray by pressing the ⏪ ⏩ keys.

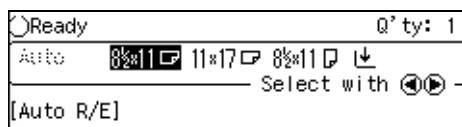

Sort/Stack/Staple

The machine can scan your originals into memory and automatically sort the copies.

❖ Sort

- Sort
- Rotate Sort
- Shift Sort (the optional finisher required or shift sort tray)

❖ Stack

- Shift Stack (optional finisher required or shift sort tray)

❖ Staple (the optional finisher required)

⚠ Limitation

- You cannot use the bypass tray with this function.

📝 Note

- The maximum tray capacity is as follows. When the number of copies exceeds the tray capacity, remove copies from the tray.

❖ Metric version

Internal tray 1	<ul style="list-style-type: none"> • B4JIS or larger: 250 sheets (80g/m²) • A4 or smaller: 500 sheets (80g/m²)
Internal tray 1 (with optional shift sort tray)	<ul style="list-style-type: none"> • B4JIS or larger: 125 sheets (80g/m²) • A4 or smaller: 250 sheets (80g/m²)
Internal tray 2	125 sheets (80g/m ²)
Finisher	<ul style="list-style-type: none"> • B4JIS or larger: 500 sheets (80g/m²) • A4 or smaller: 1,000 sheets (80g/m²)

❖ Inch version

Internal tray 1	<ul style="list-style-type: none"> • 8¹/₂" × 14" or larger: 250 sheets (20 lb) • 8¹/₂" × 11" or smaller: 500 sheets (20 lb)
Internal tray 1 (with optional shift sort tray)	<ul style="list-style-type: none"> • 8¹/₂" × 14" or larger: 125 sheets (20 lb) • 8¹/₂" × 11" or smaller: 250 sheets (20 lb)
Internal tray 2	125 sheets (20 lb)
Finisher	<ul style="list-style-type: none"> • 8¹/₂" × 14" or larger: 500 sheets (20 lb) • 8¹/₂" × 11" or smaller: 1,000 sheets (20 lb)

- The maximum tray capacity might be less than the above when you use the Rotate Sort, or Staple function.
- The maximum tray capacity might also be reduced when copy paper is considerably curled.

Sort—Sorting into Sets (123, 123, 123)

Copies can be assembled as sets in sequential order.

❖ Sort

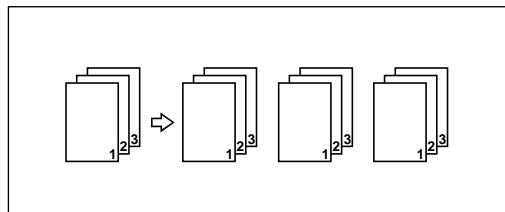

❖ **Rotate Sort**

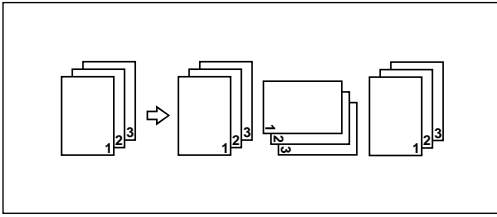

❖ **Shift Sort**

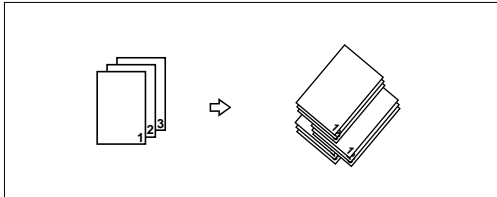

Three sorting methods are available:

❖ **Sort**

Copies can be assembled as sets in sequential order.

❖ **Rotate Sort**

Every other copy set is rotated by 90° and delivered to the copy tray.

❖ **Shift Sort (optional finisher or shift sort tray required)**

Every other copy set is shifted for ease of separation. The shift tray of the finisher or shift sort tray provides this function by sliding from side to side.

Note

- ❑ To switch among Sort, Rotate Sort, and Shift Sort modes, access the user tools. See “6. Sort” on ⇒ P.125 “3. Input/Output 2/2”.
- ❑ The paper sizes that can be used with the Rotate Sort function are as follows:

Metric version	A4, B5JIS
Inch version	8 1/2" × 11"

- ❑ To use the Rotate Sort function, two paper trays identical in size and different in direction () () are required.
- ❑ The paper sizes that can be used in Shift Sort function are as follows:

1000-sheet finisher

A3, B4JIS, A4, B5JIS, 8 1/2" × 13", 11" × 17", 8 1/2" × 14", 8 1/2" × 11"

Reference

For the paper capacity of the optional finisher, see ⇒ P.38 “Staple”.

1 Press the [Sort/Staple] key.

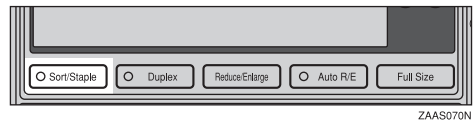

2 Make sure that [Sort / Stack] is selected, then press the [OK] key.

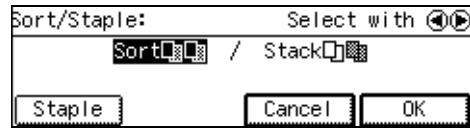

3 Enter the number of copy sets with the Number keys.

Limitation

- ❑ The maximum number of sets is 99.

4 Set your originals.

When setting a stack of originals in the document feeder

- 1** Set a stack of originals in the document feeder, then press the [Start] key.

After all the originals are scanned, the copies are delivered to the tray.

 **Note**

- ❑ If an original is misfed, reset your originals in the document feeder according to the instruction on the display. The display will indicate the number of originals you should return.

When setting an original on the exposure glass or in the document feeder

 **Reference**

See ⇒ P.28 “When SADF mode is selected”

- 1 Set the original, then press the **[Start]** key.
- 2 Set the next original, then press the **[Start]** key.

 **Note**

- ❑ Set the original in the same direction as the first one.

- 3 After all originals are scanned, press the **[#]** key.

The copies are delivered to the tray.

Stack—Delivering Copies in Page Batches (111, 222, 333)

The optional finisher or shift sort tray is required to use this function.

Copies can be assembled with each page set.

❖ **Shift Stack (optional finisher or shift sort tray required)**

Every other page set is shifted for ease of separation. The shift tray of the finisher or shift sort tray provides this function by sliding from side to side.

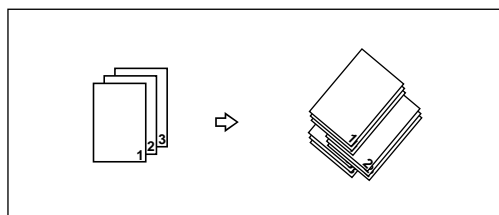



 **Reference**

For the maximum tray capacity of the optional finisher, see ⇒ P.38 “Staple”.

- 1 Press the **[Sort/Staple]** key.



- 2 Select the **[Stack  + **] by pressing the **[▶]** key. Then, press the **[OK]** key.

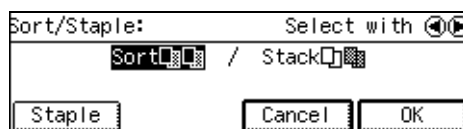

- 3 Enter the number of copies with the Number keys.
- 4 Set your originals.

When setting a stack of originals in the document feeder

- 1 Set a stack of originals in the document feeder, then press the **[Start]** key.

After all the originals are scanned, the copies are delivered to the tray.

When setting an original on the exposure glass or in the document feeder

- 1 Set the original, then press the **[Start]** key.

Note

- Start with the first page to be copied.

- 2 Set the next original, then press the **[Start]** key.

Note

- Set the original in the same direction as the first one.

- 3 After all originals are scanned, press the **[#]** key.

The copies are delivered to the tray.

Staple

The optional finisher is required to use this function.

Each copy set can be stapled together.

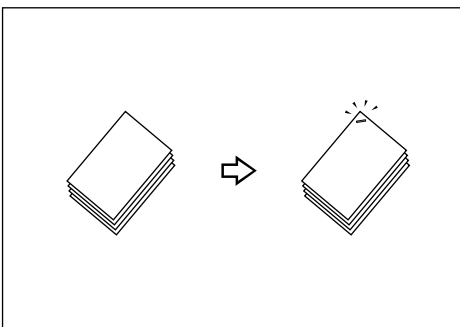

Limitation

- You cannot use the following paper with this function:
 - Post cards
 - Translucent paper
 - OHP transparencies
 - Adhesive labels
 - Curled paper
 - Low stiffness paper
 - Paper of different sizes

Note

- See the tables below for allowable paper sizes and capacities available with this feature. When the number of copies exceeds the tray capacity, copying stops. In this case, remove the copies from the shift tray and then resume copying.

	1000-sheet finisher
Paper size	A3, B4JIS, A4, B5JIS, 8" × 10", 8 1/2" × 11", 8" × 13", 8 1/2" × 13", 8 1/2" × 14", 8 1/4" × 13", 10" × 14", 11" × 17", 8K, 16K
Stapler capacity	<ul style="list-style-type: none"> A4, 8 1/2" × 11" or smaller : 30 sheets (80g/m², 20 lb) B4JIS, 8 1/2" × 14" or larger : 20 sheets (80g/m², 20 lb)
Shift tray capacity (A4, 8 1/2" × 11")	1,000 sheets (80g/m ² , 20 lb)

- In the following cases, the copies will be delivered to the shift tray without stapling.









- When the number of copies for one set is over the stapler capacity.
 - When memory reaches 0% during copying.
- When you select Staple, Sort mode is automatically selected.

Reference

If you want to add staples, see ⇒ P.107 “d Adding Staples”.

When staples are jammed, see ⇒ P.109 “e Removing Jammed Staples”.







Staple position and original direction

Original setting	Stapling position		
	Exposure glass	Document Feeder	
		 GCSTA23E	
		 GCSTA24E	

Limitation

- Original images are not rotated.

Note

- To staple in combination with Combine: 2 pages →  or 4 pages → , select  paper for  originals, or select  paper for  originals.

1 Press the [Sort/Staple] key.

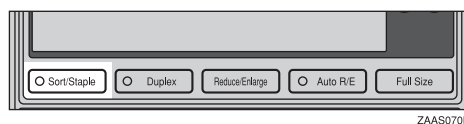

2 Press the [Staple] key, then press the [OK] key.

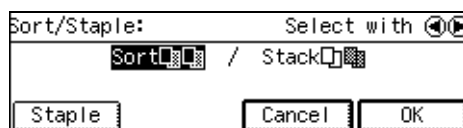

3 Enter the number of copy sets with the Number keys.

4 Set your originals.

When setting a stack of originals in the document feeder

1 Set a stack of originals in the document feeder, then press the [Start] key.

After all the originals are scanned, the copies are delivered to the tray.

When setting an original on the exposure glass or in the document feeder

1 Set the original, then press the [Start] key.

2 Set the next original, then press the [Start] key.

Note

- Set the original in the same direction as the first one.

3 After all originals are scanned, press the [#] key.

The copies are delivered to the tray.

To stop scanning

When you are using the Sort, Stack, or Staple function, the originals are scanned into memory.

- 1 Press the **[Clear/Stop]** key.

To resume scanning

- 1 Press the **[Start]** key.

Scanning is resumed.

 **Note**

- Scanned images in memory are not cleared.

To clear all scanned images

- 1 Press the **[Clear Modes]** key.

Scanning is stopped and the settings are cleared.

When memory reaches 0%

Scanning will be stopped if the size of scanned image data exceeds memory capacity.

 **Note**

- The number of originals that can be stored in memory varies depending on the memory setting and original type.
- The maximum number of originals that can be stored is about 100 pages.

 **Reference**

For details, see “08. Print Quality” and “09. Image Adjustment” in ⇒ P.117 “1. General Features 2/4”

To copy scanned so far originals

- 1 Press the **[Print]** key.

The scanned pages are delivered to the tray then the image data in memory is cleared.

- 2 Remove the copies and continue copying by following the instructions on the display.

To cancel the copy operation

- 1 Press the **[Clear]** key.

Scanning is stopped and the settings are cleared.

Copying from the Bypass Tray

The optional bypass tray is required to use this function.

Use the bypass tray to copy onto OHP transparencies, adhesive labels, translucent paper, post cards, and copy paper that cannot be set in the paper tray.

Note

- The machine can automatically detect the following sizes as standard size copy paper:

Metric version	A3, A4, A5, 8" × 13"
Inch version	11" × 17", 8 1/2" × 14", 8" × 13", 8 1/2" × 11", 5 1/2" × 8 1/2"

- If you do not use standard size copy paper, you should input vertical and horizontal dimensions. The sizes that you can input are as follows:

Metric version	<ul style="list-style-type: none"> Vertical: 90 – 305mm Horizontal: 148 – 432mm
Inch version	<ul style="list-style-type: none"> Vertical: 3.5" – 12" Horizontal: 6.0" – 17.0"

Reference

For details about paper capacity of the bypass tray, see ⇒ P.19 "Copy Paper".

- Open the bypass tray.

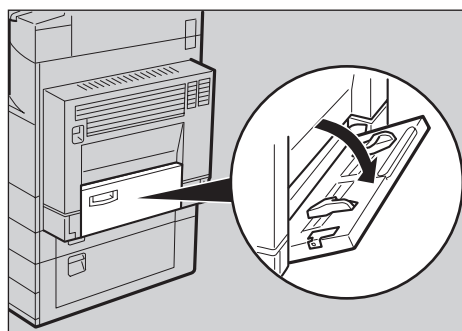

ZAAP050E

- Push up the paper guide release lever.

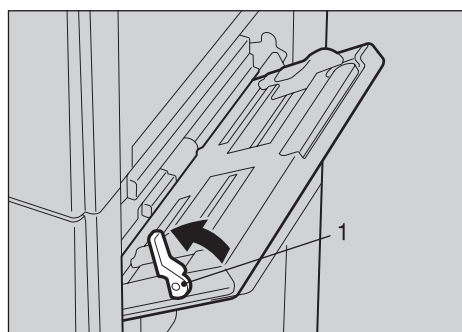

ZAAH060E

1: Paper guide release lever

- Lightly insert the copy paper face down and adjust the paper guide.

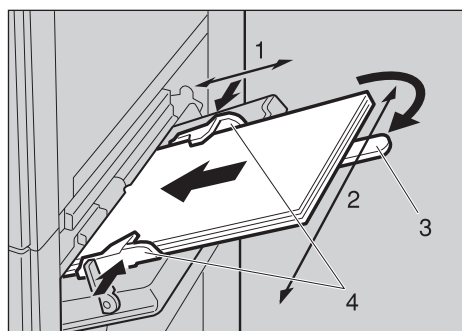

ZAAH070E

2

- 1: Horizontal size
- 2: Vertical size
- 3: Extender
- 4: Paper guide

Important

- If the guides are not flush with the copy paper, a skew image or paper misfeeds might occur.

Note

- Do not stack paper over the limit mark; otherwise a skew image or paper misfeeds might occur.
- Set the direction of the copy paper to .
- Swing out the extender to support larger size copy paper (larger than A4 , 8 1/2" x 11").
- Fan paper to get air between the sheets and avoid a multi-sheet feed.

When copying onto OHP transparencies

- 1** Lightly insert the OHP transparencies face up and adjust the paper guide.

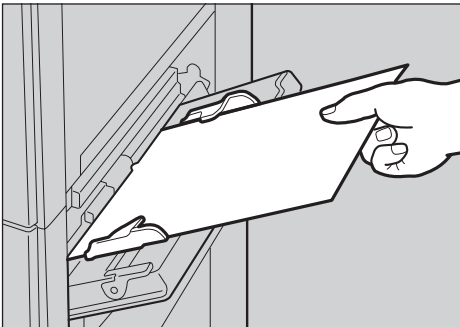

ZAAH090E

Important

- The side of OHP transparencies that is copied is fixed. Before you set the OHP transparencies in the bypass tray, check the cutting position of the OHP transparencies.

- 4** Push down the paper guide release lever.

is selected automatically.

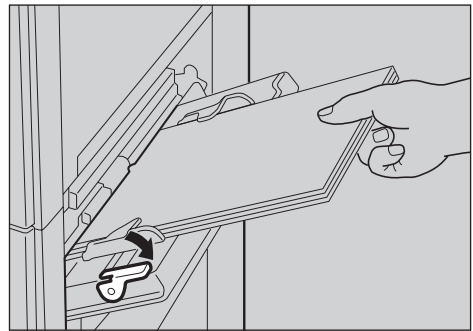

ZAAH080E

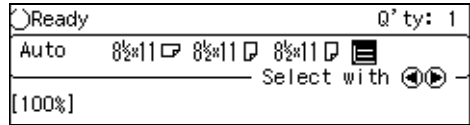

Note

- If you set A4, 8 1/2" x 11" or larger copy paper, hold the edge of the paper and push down the paper guide release lever.
- If you do not push down the paper guide release lever, a misfeed might occur.

When copying onto non-standard size copy paper

Important

- You should specify the size of copy paper to avoid paper misfeeds.

1 Press the [#] key.

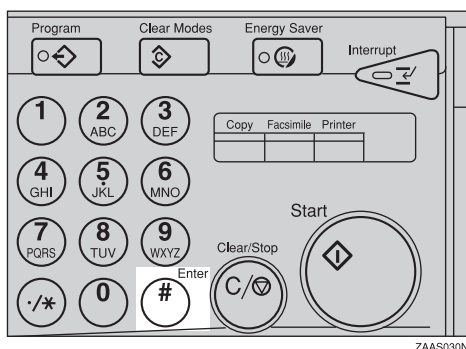

2 Press the [Pap.Size] key.

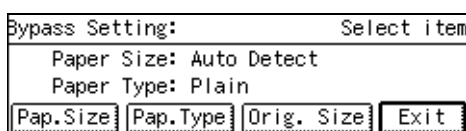

3 Select [Custom Size] key by pressing the [▶] key. Then press the [OK] key.

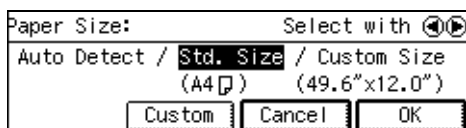

4 Enter the horizontal size of the paper with the Number keys, then press the [#] key.

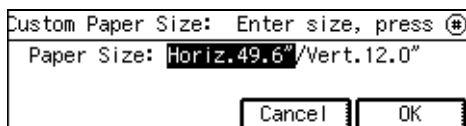

Note

To change the number entered, press the [Clear/Stop] key and enter the new number.

5 Enter the vertical size of the paper with the Number keys, then press the [OK] key.

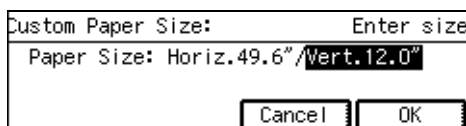

Note

To change the number entered, press the [Clear/Stop] key and enter the new number.

When you copy onto plain paper, go to step 7.

6 Press the [Pap.Type] key when copying onto thick paper.

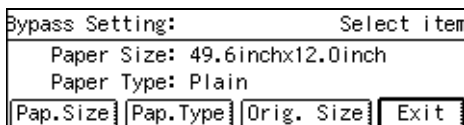

7 Select [Non Standard] by pressing the [▶] key. Then press the [OK] key.

8 Press the [Exit] key.

When copying onto non-detected standard size paper

Important

You should specify the size of paper to avoid paper misfeeds.

1 Press the [#] key.

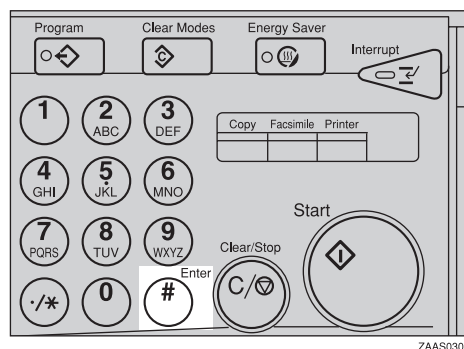

2 Press the [Pap.Size] key.

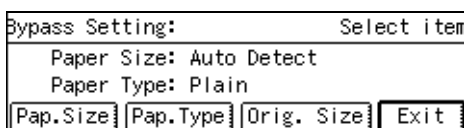

- 3 Select the [Std. Size] by pressing the **▶** key, then press the [Custom] key.

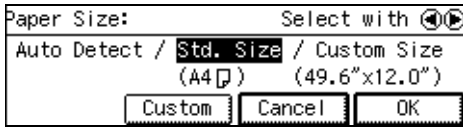

- 4 Press the [↓Next] key until your desired size is displayed.

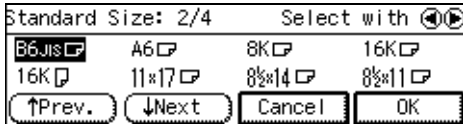

- 5 Select the desired size by pressing the **◀▶** keys. Then press the [OK] key.

Note

- When copying onto plain paper, go to step 6.

- 6 Press the [Pap.Type] key when copying onto thick paper.

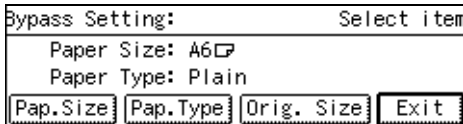

- 7 Select the [Non Standard] by pressing the **▶** key. Then press the [OK] key.

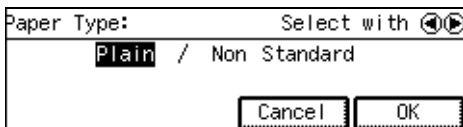

Important

- You should specify the size of copy paper to avoid paper misfeeds.

- 5 Set your originals, then press the [Start] key.

Program—Storing Your Copy Settings in Memory

You can store frequently used copy job settings in machine memory, and recall them for future use.

❖ Storing Your Settings

You can store your settings you frequently use.

❖ Deleting A Program

You can delete a stored program.

❖ Recalling A Program

You can recall a stored program.

Note

- ❑ You can store up to ten programs.
- ❑ You can select the standard mode or program No. 10 as the mode to be set when modes are cleared, the machine is reset, or immediately after the operation switch is turned on.
- ❑ Paper settings are stored based on paper size. So if you place more than one paper tray of a same size, the paper tray prioritized with the user tools will be selected first. See “12. Pap.Tray Priority ” in the System Settings Reference.
- ❑ Programs are not cleared by turning the power off or by pressing the **[Clear Modes]** key. They are canceled only when you delete or overwrite them with another program.

Storing a Program

1 Edit the copy settings so that all functions you want to store in this program are selected.

2 Press the **[Program]** key.

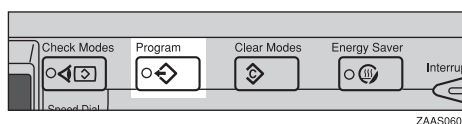

3 Press the **[Store]** key.

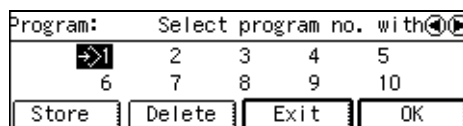

4 Select the program number you want to store these settings in with the **[Left]** **[Right]** keys. Then press the **[OK]** key.

When the settings are successfully stored, the **[Diamond]** symbol appears.

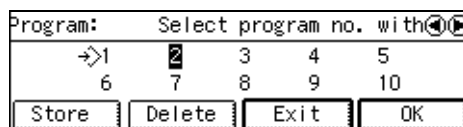

Note

- ❑ Program numbers with **[Diamond]** already have settings in them.
- ❑ If this program number is already being used, the machine will ask you if you wish to overwrite it - press the **[Yes]** or **[No]** key.

Deleting a Program

You can delete a stored program.

1 Press the **[Program]** key.

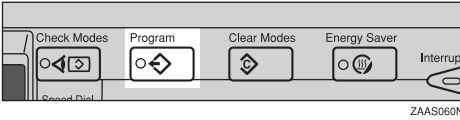

2 Press the **[Delete]** key.

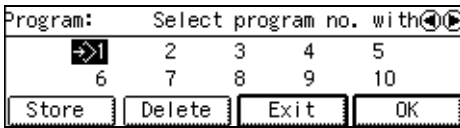

3 Select the program number you want to delete with the **⏪** **⏩** keys. Then press the **[OK]** key.

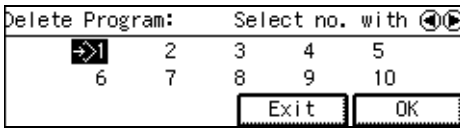

4 Press the **[Yes]** key.

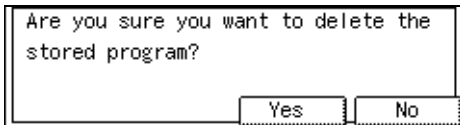

Note

To cancel the deletion, press the **[No]** key.

5 To delete another program, repeat steps **3** and **4**.

6 Press the **[Exit]** key.

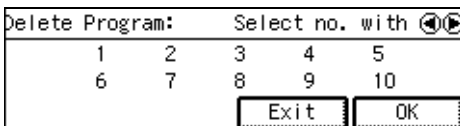

Recalling a Program

You can recall a stored program.

1 Press the **[Program]** key.

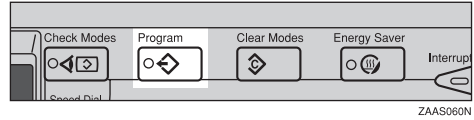

2 Select the program number you want to recall with the **⏪** **⏩** keys. Then press the **[OK]** key.

The stored settings are displayed.

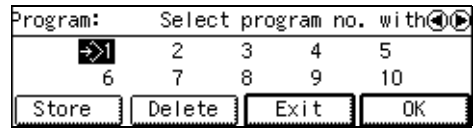

Note

You can only select program numbers marked with the **↔** symbol.

3 Set your originals, then press the **[Start]** key.

Other Functions

Energy Saver Mode—Saving Energy

If you do not operate the machine for a certain period after copying, or when you press and hold the **[Energy Saver]** key for more than one second, the display goes blank and the machine enters Energy Saver mode. When you press the **[Energy Saver]** key again, when the originals are set in the document feeder, or when the platen cover or document feeder is opened, the machine returns to the ready condition. In Energy Saver mode, the machine uses less electricity.

Energy Saver mode makes a two-step reduction in electricity: one for the period up to the time set for Low Power mode, the other for the period after that time.

Note

- The period for which the machine remains in Energy Saver mode (i.e. the period until the mode is turned off to return to the ready condition) varies with the effectiveness of energy saving.

Reference

See “06. Panel Off Timer”, “07. Energy Saver Level”, “08. Energy Saver Timer” of the System Settings Reference.

Interrupt—Temporarily Stopping One Job to Copy Something Else

You can make urgently needed copies during a multi-copy run.

Note

- The procedure for making interrupt copies depends on which kind of operation the machine is currently carrying out.

While a document is being fed

1 Press the **[Interrupt]** key.

The key indicator lights.

2 Remove the originals currently set for copying, and set your originals for interrupt copying.

Reference

For functions that cannot be used together with this function, see ⇒ P.80 “Combination Chart”.

3 Press the **Start** key.

The machine starts making your copies.

4 After interrupt copying, remove the originals for interrupt copying and the copies.

5 Press the **[Interrupt]** key again.

The key indicator goes off.

6 Reset the previous originals. Then press the **[Start]** key.

 **Note**

- The previous copy settings are recalled and the previous copy job can be resumed by pressing the **[Start]** key.

Interrupting copying after all originals have been fed

1 Press the **[Interrupt]** key.

The Interrupt key lights and copying will stop.

2 Set your original. **Reference**

For functions that cannot be used together with this function, see ⇒ P.80 “Combination Chart”.

3 Press the **[Start]** key.

The machine starts making your copies.

4 When copying is complete, remove your originals and copies.**5** Press the **[Interrupt]** key again.

The Interrupt indicator goes out.

6 Press the **[Start]** key.

The previous copy job settings will be restored and the machine will continue copying from where it left off.

User Codes

When user codes are turned on, operators must input their user codes before the machine can be operated. The machine keeps count of the number of copies made under each user code.

 **Note**

- When user codes are turned on, the machine will prompt you for your user code after the power switch is turned on or System Reset comes into effect.
- To prevent others from making copies using your user code, press the **[Clear Modes]** and **[Clear/Stop]** keys simultaneously after copying.

 **Reference**

For setting user codes, see ⇒ P.119 “1. General Features 4/4”.

Auto Start—Entering Copy Job Settings During the Warm-up Period

If you press the **[Start]** key during the warm-up period, the **[Start]** key will blink and your copies will be made as soon as warm-up finishes.

1 Make any adjustments to copy settings during the warm-up period.**2** Set your originals.**3** Press the **[Start]** key.

The **[Start]** key indicator alternately flashes red and green.

 **Note**

- To cancel Auto Start, press the **[Clear/Stop]** key.

Original Tone

The key tone sounds and an error message is displayed when you leave your originals on the exposure glass for about two seconds after copying.

Note

- To cancel this function, see "06. Original Tone" on ⇒ P.117 "1. General Features 2/4".

How to Set the Papers with Letterhead

You can make the copies on the papers with letterhead.

When you want to make one sided copies

- 1** Set your original on the exposure glass.

- 2** Set the papers in the tray with the first page face-up.

For the orientation, see the illustration below.

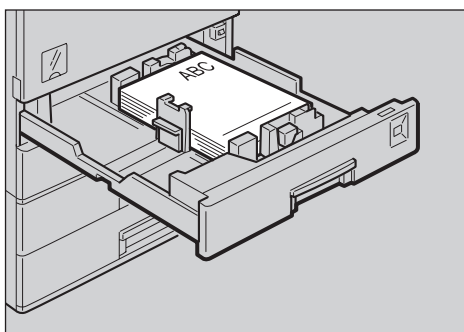

ZAAX210E

When you want to make two sided copies

- 1** Set your original on the exposure glass.
- 2** Store the papers in the tray with the first page face-down.

For the orientation, see the illustration below.

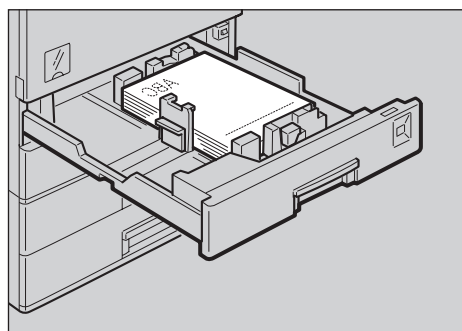

ZAAX220E

Preset Reduce/Enlarge—Reducing and Enlarging Using Preset Ratios

You can select a preset ratio for copying.

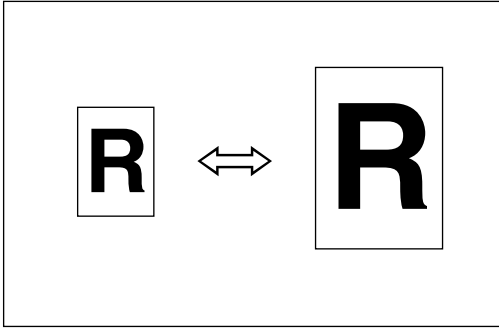

Note

- ❑ You can select one of 12 preset ratios (5 enlargement ratios, 7 reduction ratios).
- ❑ You can change the preset ratios to other ratios you frequently use. See “07. Re./En. Priority” in ⇒ P.117 “1. General Features 2/4”.
- ❑ You can select a ratio regardless of the size of an original or copy paper. With some ratios, parts of the image might not be copied or margins will appear on copies.
- ❑ Copies can be reduced or enlarged as follows:

❖ **Metric version**

Ratio (%)	Original → Copy paper size
400 ^{*1} (enlarge area by 16)	--
200 (enlarge area by 4)	A5→A3
141 (enlarge area by 2)	A4→A3, A5→A4
122	F→A3, A4→B4JIS

Ratio (%)	Original → Copy paper size
115	B4JIS→A3
93	A little reduced.
87	A3→B4JIS
82	F→A4, B4JIS→F
71 (reduce area by 1/2)	A3→A4, A4→A5
65	A3→F
50 (reduce area by 1/4)	A3→A5, F→A5
25 ^{*1} (reduce area by 1/16)	--

^{*1} When you set the originals in the document feeder, you cannot use 25% and 400 % ratio.

❖ **Inch version**

Ratio(%)	Original → Copy paper size
400 ^{*1} (enlarge area by 16)	--
200 (enlarge area by 4)	5 ¹ / ₂ " × 8 ¹ / ₂ "→11" × 17"
155 (enlarge area by 2)	5 ¹ / ₂ " × 8 ¹ / ₂ "→8 ¹ / ₂ " × 14"
129	8 ¹ / ₂ " × 11"→11" × 17"
121	8 ¹ / ₂ " × 14"→11" × 17"
93	A little reduced.
85	F→8 ¹ / ₂ " × 11"

Ratio(%)	Original → Copy paper size
78	8 ¹ / ₂ " × 14" → 8 ¹ / ₂ " × 11"
73	11" × 15" → 8 ¹ / ₂ " × 11"
65	11" × 17" → 8 ¹ / ₂ " × 11"
50 (reduce area by 1/4)	11" × 17" → 5 ¹ / ₂ " × 8 ¹ / ₂ "
25 *1 (reduce area by 1/16)	--

*1 When you set the originals in the document feeder, you cannot use 25% and 400 % ratio.

- 1 Press the [Reduce/Enlarge] key to select a ratio.

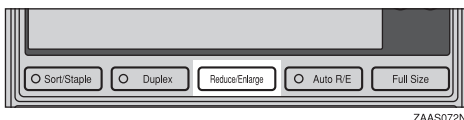

ZAA5072N

- 2 Press the [Reduce] or [Enlarge] key.

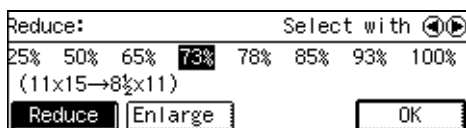

- 3 Select the ratio by pressing the ⏪ ⏩ keys.

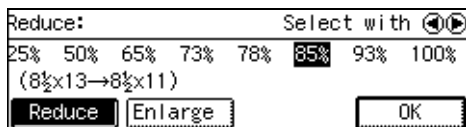

Note

- The ratio changes everytime you press the ⏪ ⏩ keys.

- 4 Press the [OK] key.
- 5 Set your originals, then press the [Start] key.

Zoom—Reducing and Enlarging in 1% Steps

You can change the reproduction ratio in 1% steps.

2

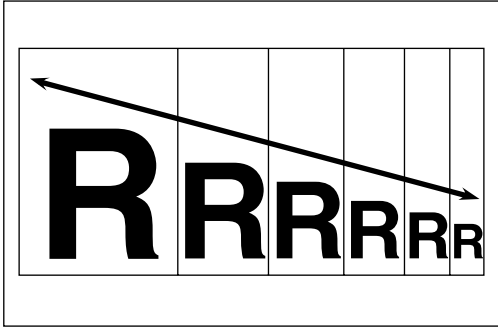

Note

- You can change the reproduction ratio from 25–400 %.
- When you set the originals in the document feeder, you can change the reproduction ratio from 50–200 %.
- You can select a ratio regardless of the size of an original or copy paper. With some ratios, parts of the image might not be copied or margins will appear on copies.
- You can select a preset ratio which is near the desired ratio, then adjust the ratio with the **[+]** or **[-]** key.

1 Press the **[Zoom]** key.

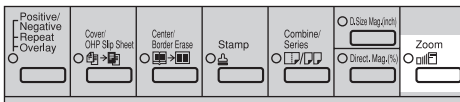

ZAA5048N

2 Enter the ratio.

When using the **[+]** or **[-]** key

1 Enter the desired reproduction ratios with the **[-]** or **[+]** key.



When using the Number keys

1 Enter the desired ratio with the Number keys.

Note

- To change the ratio entered, press the **[Clear/Stop]** key and enter the new ratio.

3 Press the **[OK]** key.

4 Set your originals, then press the **[Start]** key.

Directional Size Magnification (inch)—Stretching and Squeezing the Image into the Copy Area

The suitable reproduction ratios will be automatically selected when you enter the horizontal and vertical lengths of the original and copy image you want.

Preparation

Specify the vertical and horizontal sizes of the original and those of the copy, as shown in the illustration.

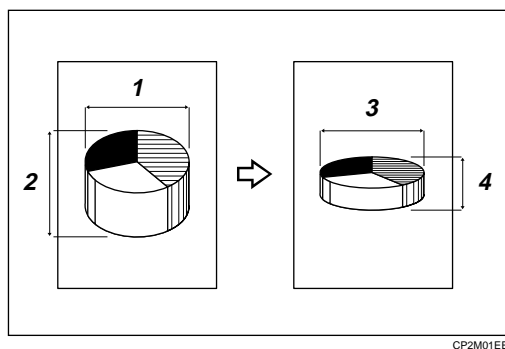

CP2M01EE

1: Horizontal original size

2: Vertical original size

3: Horizontal copy size

4: Vertical copy size

Note

- You can enter sizes within the following ranges:

Metric version	1 – 999mm (in 1mm steps)
Inch version	0.1" – 99.9" (in 0.1" steps)

- You can change the reproduction ratio from 25–400 %.

- When you set the originals in the document feeder, you can change the reproduction ratio from 50–200 %.
- If the calculated ratio is over the maximum or under the minimum ratio, it is corrected within the range of the ratio automatically. However, with some ratios, parts of the image might not be copied or blank margins will appear on copies.

1 Press the **[D. Size Mag. (inch)]** key.

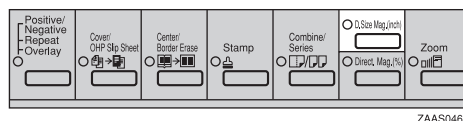

ZAAS046N

2 Enter the horizontal size of the original with the Number keys. Then press the **[#]** or **[▶]** key.



Note

- To change the value entered, press the **[Clear/Stop]** key and enter the new value.

3 Enter the horizontal size of the copy with the Number keys. Then, press the **[#]** or **[▶]** key.

4 Enter the vertical size of the original with the Number keys. Then press the **[#]** or **[▶]** key.

5 Enter the vertical size of the copy with the Number keys. Then press the [OK] key.

 **Note**

- To change the length, press the **[D. Size Mag. (inch)]** key, then press the ◀▶ keys.

6 Set your originals, then press the **[Start]** key.

Directional Magnification (%)—Stretching and Squeezing the Image in 1% Steps

Copies can be reduced or enlarged at different reproduction ratios horizontally and vertically.

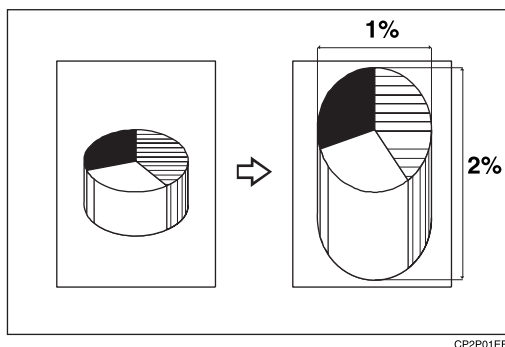

CP2P01EE

1: Horizontal %

2: Vertical %

Note

- You can change the reproduction ratio from 25–400 %.
- When you set the originals in the document feeder, you can change the reproduction ratio from 50–200 %.
- You can select a ratio regardless of the size of an original or copy paper. With some ratios, parts of the image might not be copied or blank margins will appear on copies.

1 Press the **[Direct. Mag.(%)]** key.

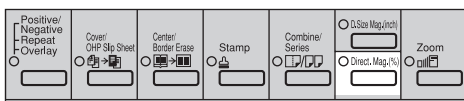

ZAAS047N

2 Enter the desired horizontal ratio with the Number keys. Then, press the **[#]** key or the **[▶]** key.

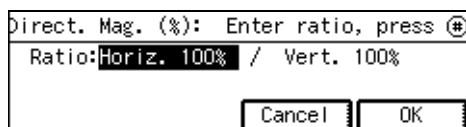

3 Enter the desired vertical ratio with the Number keys. Then, press the **[OK]** key.

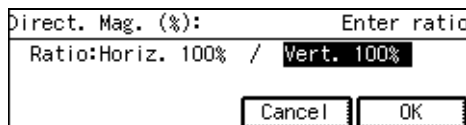

Note

- To change the ratio, press the **[Direct. Mag.(%)]** key, then press the **[◀▶]** keys, then enter the new ratio.

4 Set your originals, then press the **[Start]** key.

Center/Border Erase—Erasing the Center and the Border

This function erases the center and/or all four sides of the original image, such as book originals.

❖ Center Erase

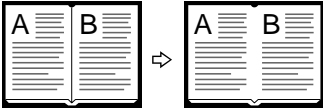

CenterEE

❖ Border Erase

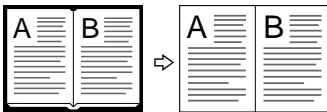

BorderEE

Two methods are available:

❖ Center

This mode erases the center margin of the original image.

❖ Border

This mode erases the surrounding area of the original image.

Note

- ❑ You can change the width of the erased margin as follows:

Metric version	3 – 50mm (in 1mm steps)
Inch version	0.1" – 2.0" (in 0.1" steps)

- ❑ The default size of the erased margin is as follows. You can change this with the user tools. See “01. Border Erase Width” and “02. Center Erase Width” in ⇒ P.121 “2. Adjust Image 1/3”.

Metric version	10mm
Inch version	0.4"

- ❑ The position of the margin to be erased is determined according to the copy paper size.

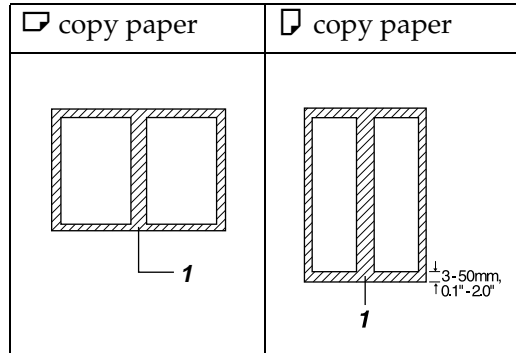

- ❑ 1: Erased part
- ❑ You can use the Center Erase and Border Erase functions together.

1 Press the **[Center/Border Erase]** key.

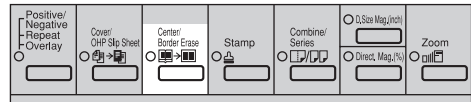

ZAAS043N

2 Select the part to be erased.

Center

- 1 Press the **[Center]** key.

- 2 Enter the center width with the Number keys. Then press the **[OK]** key.

Note

- To change the value entered, press the **[Clear/Stop]** key and enter the new value.

- 3 Press the **[Exit]** key.

Border

- 1 Press the **[Border]** key.

- 2 Enter the border width with the Number keys. Then press the **[OK]** key.

Note

- To change the value entered, press the **[Clear/Stop]** key and enter the new value.

- 3 Press the **[Exit]** key.

- 3 Set your originals, then press the **[Start]** key.

Combine—Combining Originals into One Copy

Use this feature to combine several original images onto one or more pages.

❖ 2 Orig. →

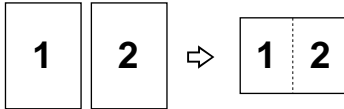

Combine1

❖ 8 Orig. →

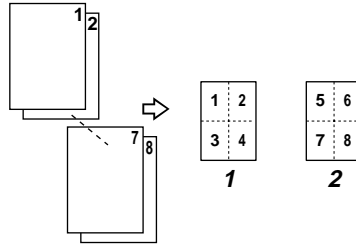

Combine3

❖ 4 Orig. → , 4 Orig. →

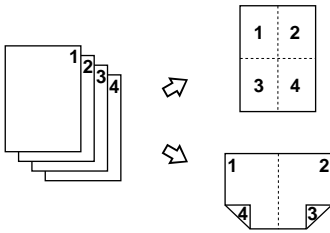

Combine2

❖ 16 Orig. →

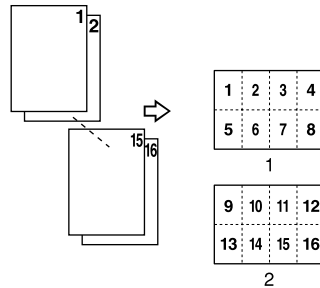

GC6IX000E

❖ 8 Orig. →

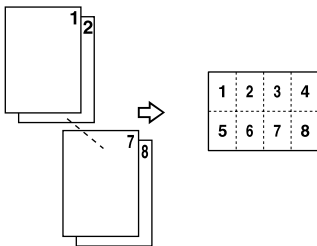

GCEIG000E

1: Front

2: Back

Six methods are available:

❖ 2 Orig. →

This mode copies two facing pages onto a one-sided copy.

❖ 4 Orig. →

4 one-sided pages are copied onto a single one-sided sheet.

❖ 4 Orig. → (optional duplex unit is required.)

4 one-sided pages are copied onto 1 two-sided sheet, 2 original images on each side.

❖ **8 Orig.** → 

Copies eight 1-sided originals together onto one side of copy paper.

❖ **8 Orig.** →  **(optional duplex unit is required.)**

8 one-sided pages are copied onto 1 two-sided sheet, 4 original images on each side.

❖ **16 Orig.** →  **(optional duplex unit is required.)**

16 one-sided pages are copied onto 1 two-sided sheet, 8 original images on each side.

Original direction (when set in document feeder)

- Originals reading from left to right

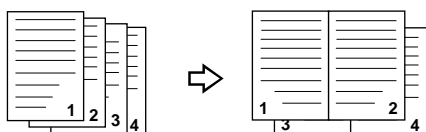

Combine5

- Originals reading from top to bottom

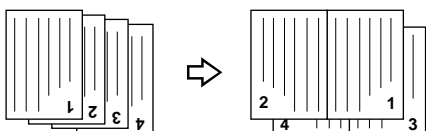

Combine6

! **Limitation**

- ❑ You cannot use the bypass tray with this function.
- ❑ The machine cannot copy originals different in size and direction.

 **Note**

- ❑ The number of originals copied (combined) can be 2, 4, 8, or 16.
- ❑ In this mode, the machine selects the reproduction ratio automatically. This reproduction ratio depends on the copy paper sizes and the number of originals.
- ❑ You can change the reproduction ratio from 25–400 %.
- ❑ When you set the originals in the document feeder, you can change the reproduction ratio from 50–200 %.
- ❑ If the calculated ratio is under the minimum ratio, it is corrected within the range of the ratio automatically. However, with some ratios, parts of the image might not be copied or blank margins appear on copies.
- ❑ A separation line between originals can be printed with the user tools. See “06. Line(Combine)” in ⇒ P.122 “2. Adjust Image 2/3”.
- ❑ Even if the direction of originals is different from that of the copy paper, the machine will automatically rotate the image by 90° to make copies properly. (When the Auto Reduce/Enlarge function is selected)
- ❑ You can make copies even if the number of originals is less than the number required in the selected mode. You can also disable this function with the user tools. See “2. Comb. Auto Eject ” in ⇒ P.124 “3. Input/Output 1/2”.

- When the number of originals placed is less than the number specified for combining, the last page(s) will be copied blank as shown in the illustration.

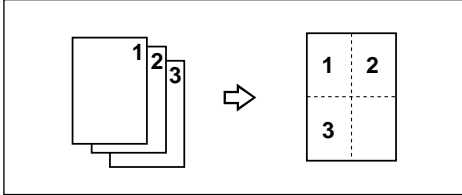

- Direction of the originals and arrangement of combined images

❖ Portrait (📄) originals

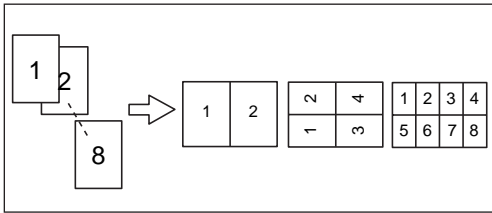

GCSHUY1E

❖ Landscape (📄) originals

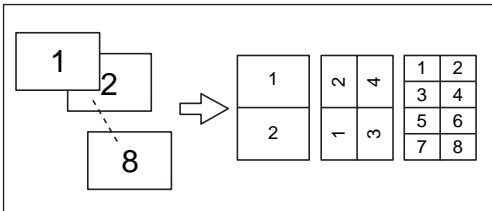

GCSHUY2E

1 Press the **[Combine/Series]** key.

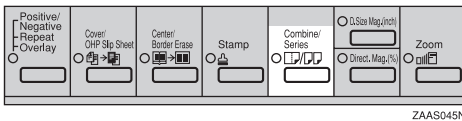

ZAAS045N

2 Press the **[Combine]** key.

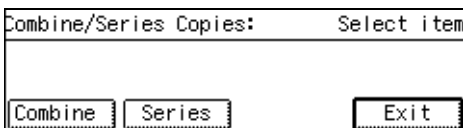

3 Press the **[Original]** key.

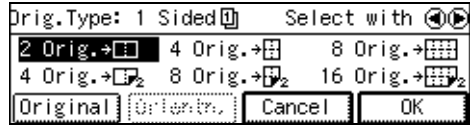

4 Select your original type with the **⏪ ⏩** keys. If your original type is 1 sided, go to Step **7**.

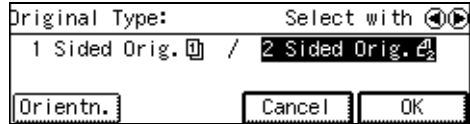

5 Press the **[Orientn.]** key, then select the original orientation.

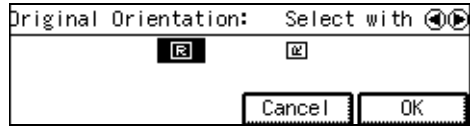

6 Press the **[OK]** key.

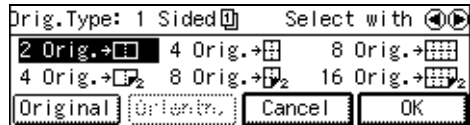

7 Press the **[OK]** key.

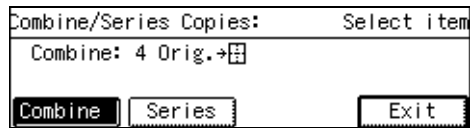

8 Select the desired combine modes with the **⏪ ⏩** keys. Then press the **[OK]** key.

Note

- In 4 pages→ mode, 8 pages→ mode or 16 pages→ mode, you can specify the orientation of originals (**[Top to Top]** **[Top to Bottom]**). See .

9 Press the **⏪ ⏩** keys to select the copy paper.

10 Set your originals.

When setting an original on the exposure glass or in the document feeder

- ➊ Set the original, then press the **【Start】** key.
- ➋ Set the next original, then press the **【Start】** key.

 **Note**

- To finish copying, press the **【#】** key to eject the copy.

When setting a stack of originals in the document feeder

- ➊ Set your originals, then press the **【Start】** key.

Series Copies—Making One-sided Copies from Various Originals

You can make one-sided copies from two facing pages of bound (book) originals and from two-sided originals.

Two methods are available:

❖ Book

You can make one-sided copies from two facing pages of a bound original (book).

❖ 2-Sided (The optional document feeder is required.)

You can make one-sided copies from two-sided originals.

! Limitation

- ❑ You cannot use the bypass tray with this function.



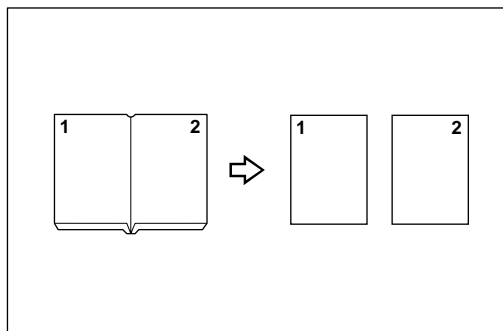



Book —Making One-sided Copies from Two Facing Page of a Bound Original (Book)







Note

- ❑ Refer to the following table when you select original and copy paper sizes with a ratio of 100%:

❖ Metric version

Original	Copy paper
A3 	A4  × 2 sheets
B4JIS 	B5JIS  × 2 sheets
A4 	A5  × 2 sheets

❖ Inch version

Original	Copy paper
11" × 17" 	8 ¹ / ₂ " × 11"  × 2 sheets
8 ¹ / ₂ " × 11" 	5 ¹ / ₂ " × 8 ¹ / ₂ "  × 2 sheets

1 Press the [Combine/Series] key.

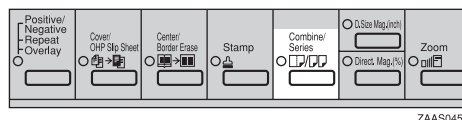

2 Press the [Series] key.

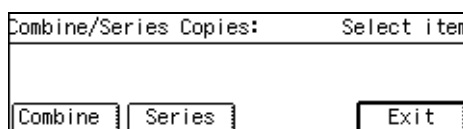

3 Select [Book →] with the keys. Then press the [OK] key.

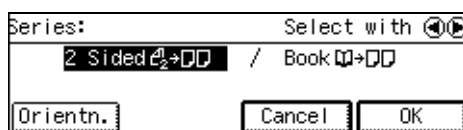

4 Select the paper by pressing the keys.

5 Set your originals, then press the [Start] key.

2-Sided —Making One-sided Copies from Two-sided Originals

The optional document feeder is required to use this function.

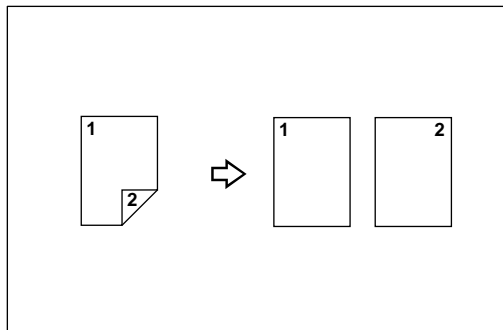

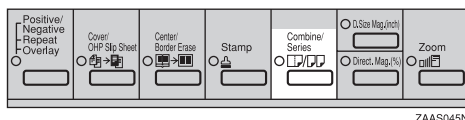

1 Press the **[Combine/Series]** key.

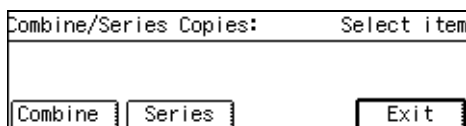

ZAAS045N

2 Press the **[Series]** key.



3 Make sure that the **[2 Sided **] is selected then press the **[Orientn.]** key.

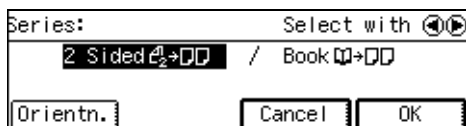

4 Select the original orientation.

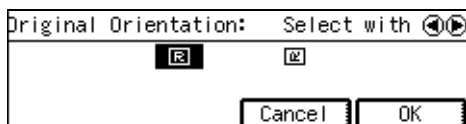

5 Press the **[OK]** key.

6 Select the paper by pressing the **⏪ ⏩** keys.

7 Set your originals, then press the **[Start]** key.

Duplex—Making Two-Sided Copies

The optional duplex unit is required to use this function.

Three methods are available:

❖ 1 sided $\square_1 + \square_2$

This mode makes two-sided copies from one-sided originals.

❖ 2-sided $\square_2 + \square_2$

This mode makes two-sided copies from two-sided originals.

❖ Book $\square + \square_2$

This mode makes two-sided copies from facing pages of a bound original (book).

🔔 Limitation

❑ You cannot use the following types of copy paper in this function:

- Paper smaller than A5 \square , $5\frac{1}{2}" \times 8\frac{1}{2}" \square$
- Translucent paper
- Adhesive labels
- OHP transparencies
- Post cards

❑ You cannot use the bypass tray with this function.

❑ When the paper type is set to "Non-Standard" in the "Changing the Paper Size in the Tray 2", duplex copying is not available with the tray 2. Select another paper tray, change the paper in the tray 2, or set the paper type to Normal or Recycled. See \Rightarrow P.31 "Selecting Copy Paper", \Rightarrow P.105 "Changing the Paper Size in Tray 2".

🔖 Note

❑ The following paper limitations apply:

Metric version	Minimum size	A5 \square
	Weight	64 – 105g/m ²
Inch version	Minimum size	$5\frac{1}{2}" \times 8\frac{1}{2}" \square$
	Weight	20 – 28 lb

1 Sided $\square_1 + \square_2$ —Making Two-sided Copies from One-sided Originals

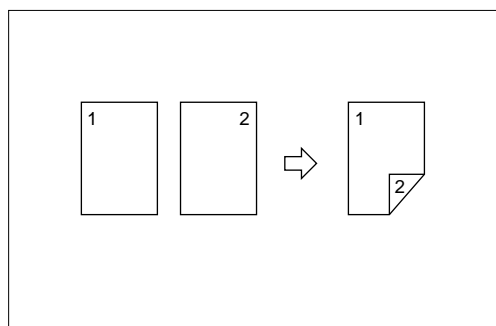

🔖 Note

❑ If you set an odd number of 1-sided originals in the document feeder (ADF), the reverse side of the last page is left blank. You can disable this function to make the delivered last page not be blank. See "1. Duplex Auto Eject" in \Rightarrow P.124 "3. Input/Output 1/2".

❑ When original images are copied, the images are shifted by the width of the binding margin. You can adjust the binding margin or binding position. You can also change their default values. See "03. Left Dup. Margin", "04. Top Dup. Margin" in \Rightarrow P.121 "2. Adjust Image 1/3".

Originals and copy direction

You can select the orientation ([Top to Top], [Top to Bottom]). See .

- Top to Top

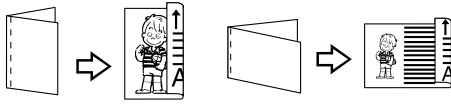



Duplex1

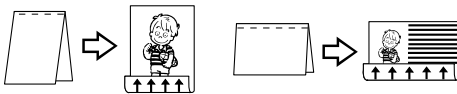

- Top to Bottom



Duplex2

Original direction and completed copies

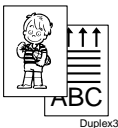
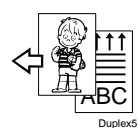
The resulting copy image will differ according to the direction in which you set your original (lengthwise  or widthwise .

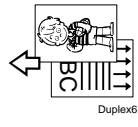
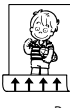
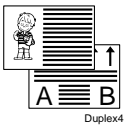
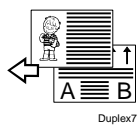
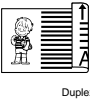
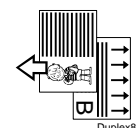
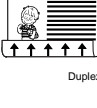
Original	Orientation	Result ^{*1}
 <p>Duplex3</p>	 <p>Duplex5</p>	<ul style="list-style-type: none"> • [Top to Top]  <p>Duplex9</p>
	 <p>Duplex6</p>	<ul style="list-style-type: none"> • [Top to Bottom]  <p>Duplex10</p>
 <p>Duplex4</p>	 <p>Duplex7</p>	<ul style="list-style-type: none"> • [Top to Top]  <p>Duplex11</p>
	 <p>Duplex8</p>	<ul style="list-style-type: none"> • [Top to Bottom]  <p>Duplex12</p>

^{*1} The illustrations show the directions of copied images on the front and back, not the directions of delivery.

- 1 Press the [Duplex] key.

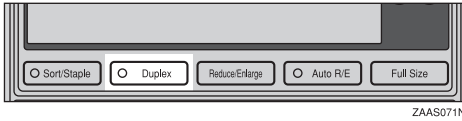

- 2 Make sure that [1 Sided \rightarrow] is selected.

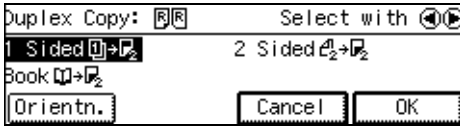

When setting the copy direction

Select the orientation of the copy paper.

Note

- If you do not set the copy direction, [Top to Top] will be selected automatically.

- 1 Press the [Orientn.] key.

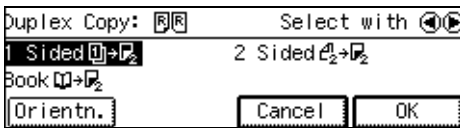

- 2 Select the desired orientation with the \leftarrow \rightarrow keys. Then press the OK key.

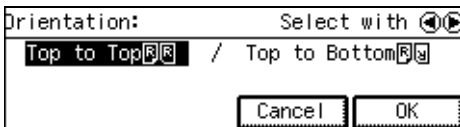

- 3 Press the [OK] key.

- 4 Set your originals.

When setting an original on the exposure glass or in the document feeder

- 1 Set the original, then press the [Start] key.

- 2 Set the next original, then press the [Start] key.

When setting a stack of originals in the document feeder

- 1 Set your originals, then press the [Start] key.

2 Sided \rightarrow —Making Two-sided Copies from Two-sided Originals

The optional document feeder is required to use this function.

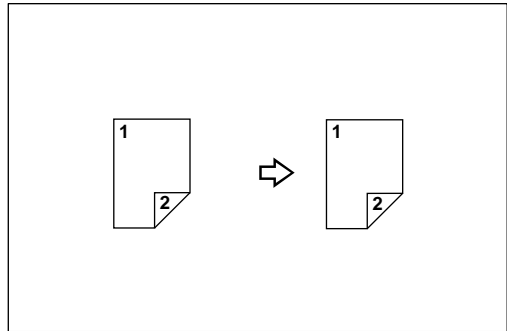

- 1 Press the [Duplex] key.

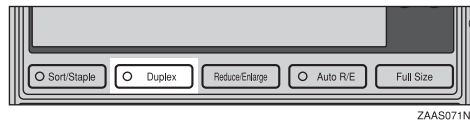

- 2 Select [2 Sided \rightarrow] with the \rightarrow key, then press the [OK] key.

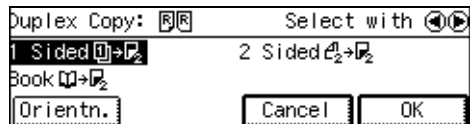

- 3 Set your originals.

When setting an original on the exposure glass or in the document feeder

- ❶ Set the original, then press the **[Start]** key.
- ❷ Set the next original, then press the **[Start]** key.

When setting a stack of originals in the document feeder

- ❶ Set your originals, then press the **[Start]** key.

Book —Making Two-Sided Copies from Facing Pages of a Bound Original (Book)

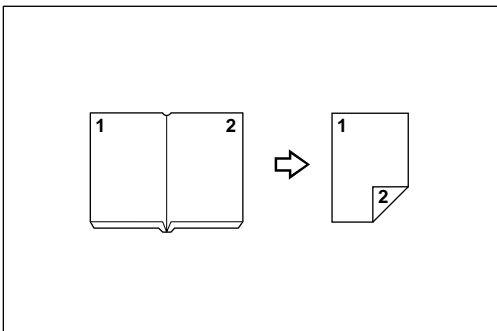

Note

- ☐ Refer to the following table when you select original and copy paper sizes with a ratio of 100%:

❖ Metric version

Original	Copy paper
A3	A4 (2-sided)
B4JIS	B5JIS (2-sided)
A4	A5 (2-sided)

❖ Inch version

Original	Copy paper
11" × 17"	8 ¹ / ₂ " × 11" (2-sided)
8 ¹ / ₂ " × 11"	5 ¹ / ₂ " × 8 ¹ / ₂ " (2-sided)

- ❶ Press the **[Duplex]** key.

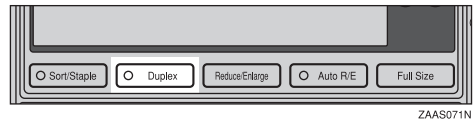

- ❷ Select **[Book]** with the **▶** key, then press the **[OK]** key.

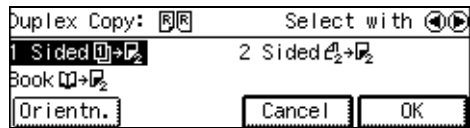

- ❸ Set your originals.

When setting an original on the exposure glass or in the document feeder

- ❶ Set the original, then press the **[Start]** key.
- ❷ Set the next original, then press the **[Start]** key.

When setting a stack of originals in the document feeder

- ❶ Set your originals, then press the **[Start]** key.

Cover—Adding or Inserting Sheets

Use this feature to have cover pages inserted/copied onto using different paper.

Preparation

Before you can use this function, you need to select the “Tray 2” or the “Bypass” as Cover Only Tray with the “12. Cover/OHP Tray”.
⇒ P.118 “1. General Features 3/4”

There are two types in this function:

❖ Front Cover

The first page of your original is copied on a specific paper for covers.

❖ Both Covers

The first and last pages of your originals are copied on specific paper sheets for covers.

Note

- ❑ The cover or slip sheets should be identical in size and direction with the copy paper.
- ❑ If Blank Cover mode is selected, the cover will not be counted as a copy.

Front Cover—Copying or Adding a Front Cover

The first page of your original is copied on a specific paper for covers.

❖ Copy

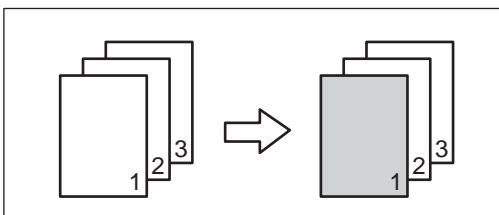

❖ Blank

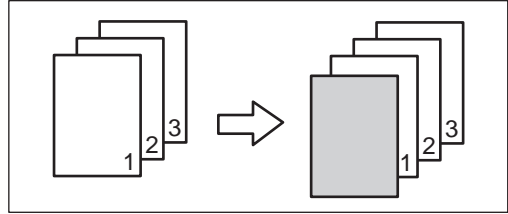

Note

- ❑ You can specify whether to copy onto cover paper. If you select **[Copy]**, the first page will be copied on the cover sheet. If you select **[Blank]**, a cover sheet will just be inserted before the first copy.

1 Press the **[Cover/OHP Slip Sheet]** key.

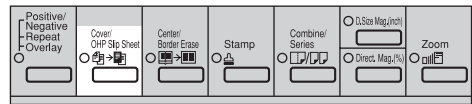

ZAA5042N

2 Press the **[Front]** key.

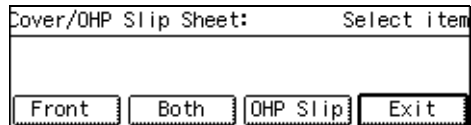

3 Specify whether to copy on the cover sheet with the **[Left/Right]** keys. Then press the **[OK]** key.

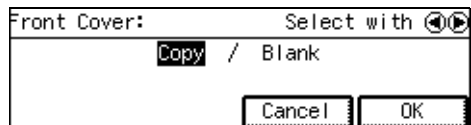

4 Press the **[Exit]** key.

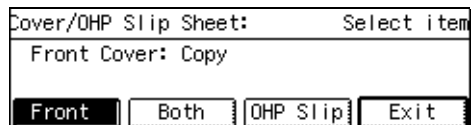

- 5 Set cover sheets on the bypass tray or in the 2nd paper tray.
- 6 Select the tray which identical in size and direction with the copy paper with the ⏪ ⏩ keys.
- 7 Set your originals, then press the [Start] key.

Both Covers—Copying or Adding Front and Back Covers

The first and last pages of your originals are copied on specific paper for covers.

❖ Copy

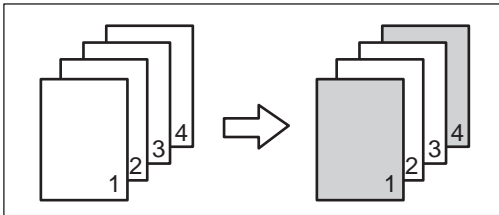

❖ Blank

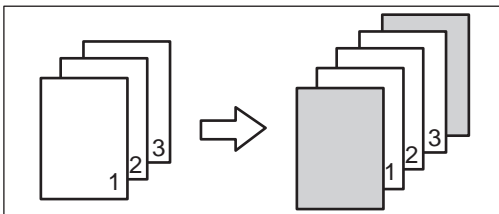

📎 Note

- ❑ You can specify whether to copy onto the cover sheet. If you select **[Copy]**, the first and last pages will be copied on the cover sheets. If you select **[Blank]**, a cover sheet will just be inserted before the first copy and another sheet after the last copy.

- 1 Press the [Cover/OHP Slip Sheet] key.

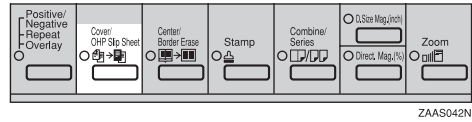

- 2 Press the [Both] key.

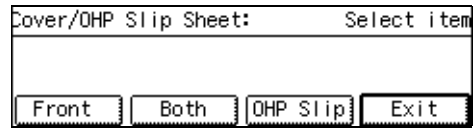

- 3 Specify whether to copy on the cover sheet with the ⏪ ⏩ keys. Then press the [OK] key.

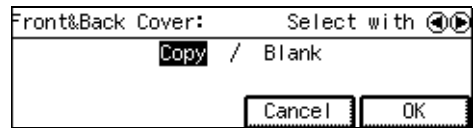

- 4 Press the [Exit] key.

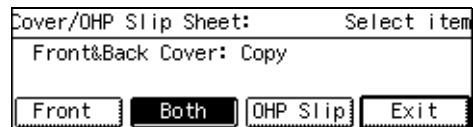

- 5 Set cover sheets on the bypass tray or in the tray 2.

- 6 Select the copy paper tray containing paper identical in size and direction to the cover paper with the ⏪ ⏩ keys.

- 7 Set your originals, then press the [Start] key.

OHP Slip Sheet—Copying or Inserting Slip Sheets

For each original page, a slip sheet will be placed after each copy, or a slip sheet will be fed and the same original image copied onto this slip sheet.

2

❖ Copy

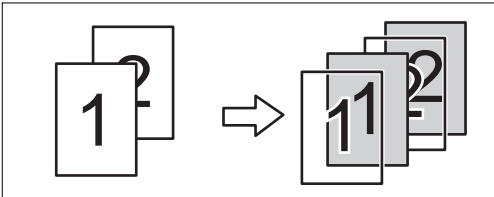

❖ Blank

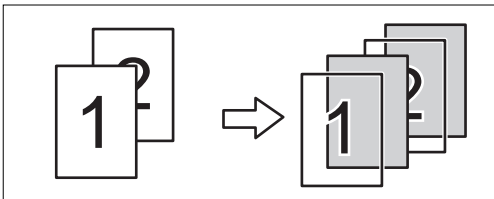

Preparation

Before you can use this function, you need to select the “Tray 2” or the “Bypass” as Cover Only Tray with the “12. Cover/OHP Tray”.
⇒ P.118 “1. General Features 3/4”

Note

- ❑ Set slip sheets of the same size and in the same orientation as OHP transparencies.
- ❑ You can specify whether to make copies onto the inserted slip sheets.
- ❑ If you do not copy onto a slip sheet, the sheet is excluded from the number of copies counted.

1 Press the **[Cover/OHP Slip Sheet]** key.

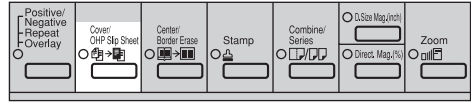

ZAAS042N

2 Press the **[OHP Slip]** key.

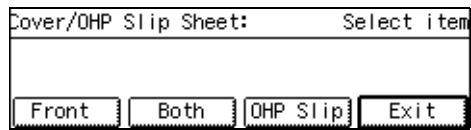

3 Specify whether to copy on the slip sheet with the **⏪ ⏩** keys. Then press the **[OK]** key.

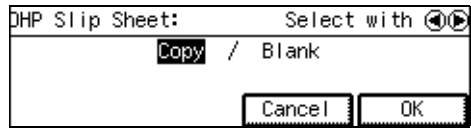

4 Set OHP transparencies in the bypass tray or tray 2.

5 Press the **[Exit]** key.

6 Set the slip sheets in the paper tray, then select this tray by pressing the **⏪ ⏩** keys.

7 Set your originals, then press the **[Start]** key.

Positive/Negative—Copying in Complementary Colors

If your original is black and white, copy images are inverted.

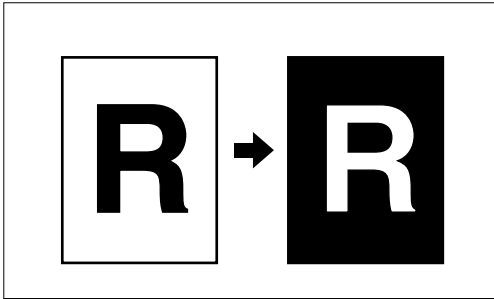

2

1 Press the **[Positive/Negative]** key.

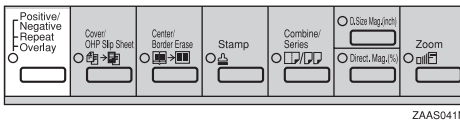

2 Press the **[Pos/Neg.]** key.

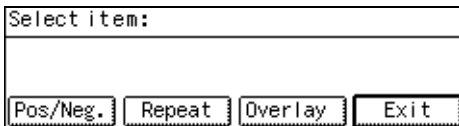

3 Press the **[Exit]** key.

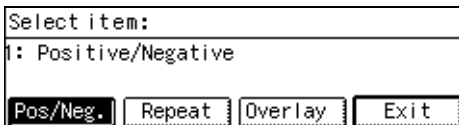

4 Set your originals, then press the **[Start]** key.

Repeat Image—Repeating an Image over the Entire Copy

The original image is copied repeatedly.

2

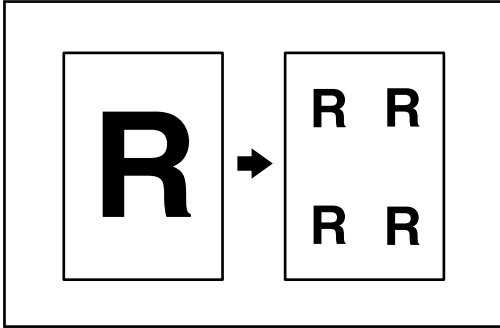

Note

The number of repeated images depends on the original size, copy paper size, and reproduction ratio. Refer to the following table.

❖ Original: 5 1/2" x 8 1/2" / Copy paper: 8 1/2" x 11" or Original: 5 1/2" x 8 1/2" / Copy paper 8 1/2" x 11"

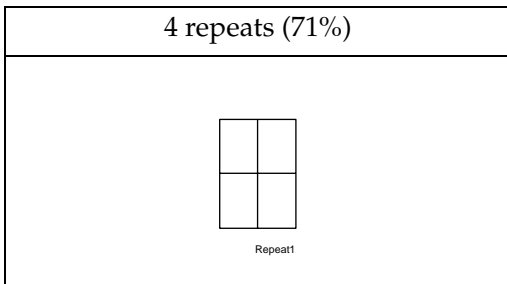

❖ Original: 5 1/2" x 8 1/2" / Copy paper: 8 1/2" x 11" or Original: 5 1/2" x 8 1/2" / Copy paper 8 1/2" x 11"

2 repeats (100%)	8 repeats (50%)
<p>Repeat3</p>	<p>Repeat4</p>

- ❑ Part of a repeated image might not be copied depending on the copy paper size, copy paper direction or reproduction ratio.
- ❑ You can insert separate lines between repeated images. See "07. Line (Repeat)" in ⇒ P.122 "2. Adjust Image 2/3".

1 Select the size of the copy paper and the reproduction ratio.

2 Press the [Repeat] key.

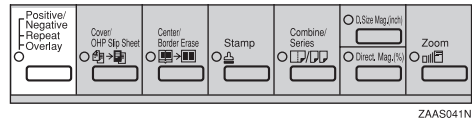

3 Press the [Repeat] key.

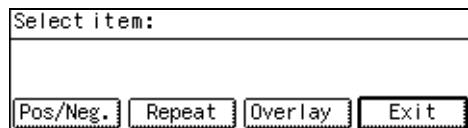

4 Press the [Exit] key.



5 Set your original, then press the [Start] key.

Merging Images (Overlay)—Merging Two Different Originals

Preparation

There are three ways to make Overlay copies.

- **Overlay-1**
Two different originals can be merged onto the same copy paper.
- **Overlay-2**
The machine merges two originals and only the overlapped image will be copied.
- **Overlay-3**
Originals are merged and where black overlaps black the image is inverted (see the above illustration).

The machine can merge two different originals onto the same copy paper.

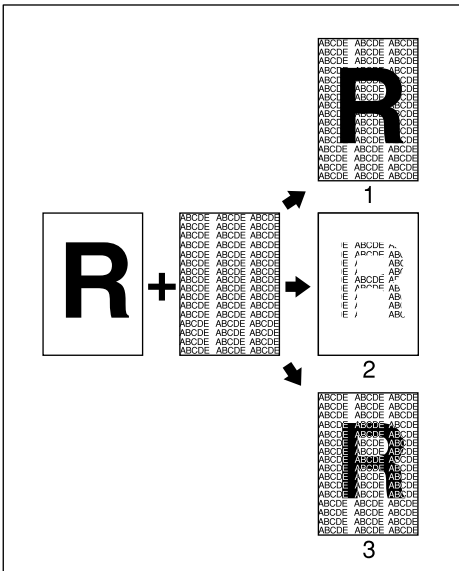

GCCOMP3E

- 1: Overlay-1
- 2: Overlay-2
- 3: Overlay-3

Limitation

- ❑ You cannot change the paper size once you have selected the Overlay feature.
- ❑ When you set different sized originals in the document feeder, parts of the image might not be copied. Set the original on the exposure glass.

1 Press the [Overlay] key.

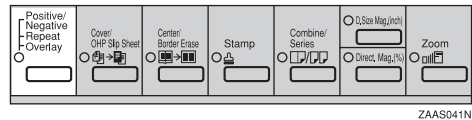

ZAAS041N

2 Press the [Overlay] key.

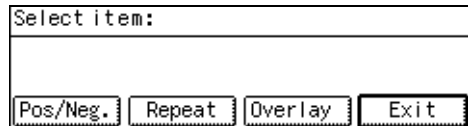

3 Select the desired mode with the left and right arrow keys. Then press the [OK] key.

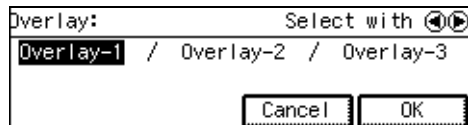

4 Press the [Exit] key.



5 Set your originals, then press the **[Start]** key.

 **Note**

- When setting originals on the exposure glass, start with the first page to be copied. After the first original is scanned, remove originals and repeat step **5**.

Preset Stamp—Printing Preset Messages on Your Copies

One of the following seven messages can be stamped on copies.

- CONFIDENTIAL
- COPY
- URGENT
- PRIORITY
- For Your Information
- PRELIMINARY
- For Internal Use Only

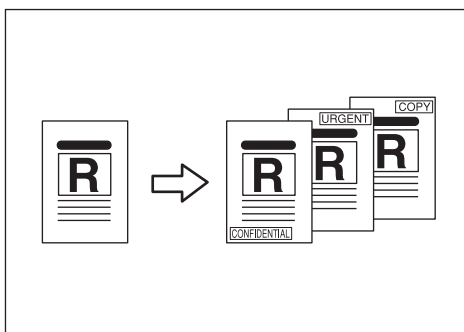

CCSTAM2E

⚠ Limitation

- You cannot use the bypass tray with this function.
- One message can be stamped at a time.

📝 Note







- You can change the stamp position and orientation. See “10. Stamp Position” in ⇒ P.127 “4 Stamp Setting 3/3”.
- You can select the print page. See ⇒ P.77 “When changing the numbering format”
- You can change the stamp size and stamp density. See “08. Stamp Size” in ⇒ P.126 “4 Stamp Setting 2/3”, “09. Stamp Density” in ⇒ P.127 “4 Stamp Setting 3/3”.

💡 Original setting, stamp position and orientation

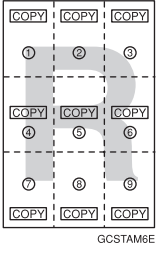
You can select the following positions and orientations.

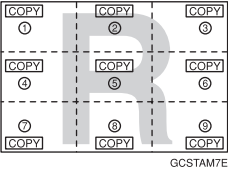
Key on Display	Stamp Position
	①
	②
	③
	④
	⑤
	⑥
	⑦
	⑧
	⑨

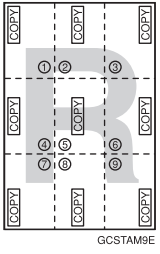
2

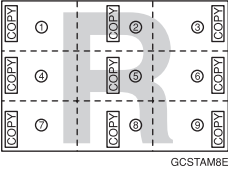
Original Setting	Ori-entation	Copy Results
 GCRSET4E	AB	 GCSTAM6E
 GCRSET5E		 GCSTAM7E
 GCRSET4E	HB	 GCSTAM8E
 GCRSET5E		 GCSTAM8E

1 Press the [Stamp] key.

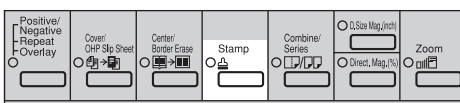

ZAAS044N

2 Press the [Preset] key.

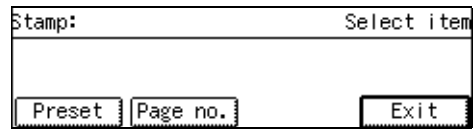

3 Select the desired message by pressing the \leftarrow \rightarrow keys. Then press the [OK] key.

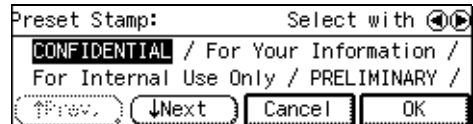

When changing the stamp position and orientation

1 Press the [Position] key.

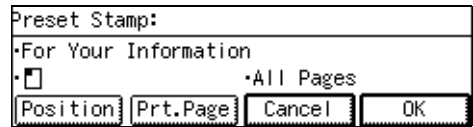

2 Select the desired stamp position by pressing the \leftarrow \rightarrow keys. Then press the [OK] key.

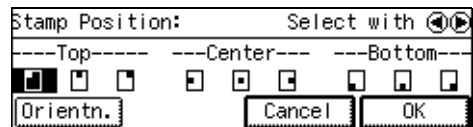

3 If you want to change the stamp orientation, press the [Orientn.] key.

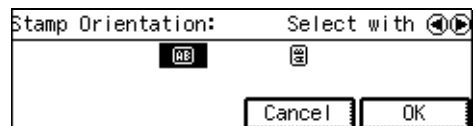

4 Press the [OK] key.

When changing the numbering format

- 1 Press the [Prt.Page] key.

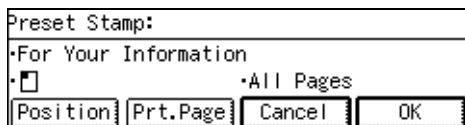

- 2 Select the desired mode by pressing the ⏪ ⏩ keys. Then press the [OK] key.

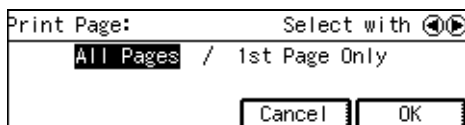

- 4 Press the [OK] key.
- 5 Press the [Exit] key.
- 6 Set your originals, then press the [Start] key.

 **Note**

- When you set the original on the exposure glass and select the [1st Page Only] key, press the [#] key after all originals are scanned.

Page Numbering—Printing Page Numbers

You can print page numbers on your copy. There are three types of page numbering (P.1, P2..., 1/5, 2/5..., or -1-, -2-...).

2

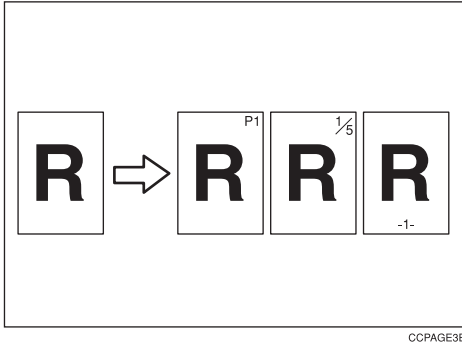

Note

- You can change the numbering position. See “05. Page No. Position” in ⇒ P.126 “4 Stamp Setting 2/3”.
- If you want to adjust the numbering position or numbering size, See “02. Page No. Size” or “05. Page No. Position” in ⇒ P.125 “4 Stamp Setting 1/3”.
- If the page number is up to 999, page numbering is not printed.
- If you select numbering format $1/5$, $2/5$,... and if the total pages are over, page numbering is not printed.
- When you select page numbering, Sort mode is automatically selected.

❖ **Original setting, stamp position and orientation**

Original Setting	Ori-entation	Copy Results

1 Press the **[Stamp]** key.

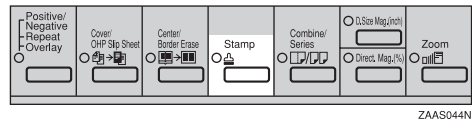

2 Press the **[Page No.]** key.

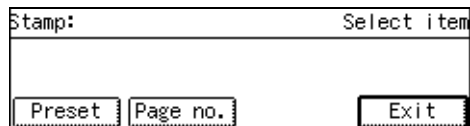

- 3** Select the desired mode by pressing the \leftarrow \rightarrow keys. Then press the [OK] key.

If you selected numbering format P1, P2, ... or -1-, -2-, ... in step **3**

- 1** If you wish, do one of the following:

- To change the page on which numbering starts, press the [Prt.Page] key.
- To change the position of page number, press the [Position] key.

If you selected numbering format 1/5, 2/5, ... in step **3**

- 1** Enter the page on which numbering will start (Start Page), the total number of pages (Total Pages).

- 2** Press the [OK] key.
- 3** If you wish, do one of the following:
- To change the page on which numbering starts, press the [Prt.Page] key.

- To change the position of page numbers, press the [Position] key.

- 4** Press the [OK] key.

Note

- If you want to change the entered numbers, press the [Prt.Page] key.

To change the numbering position

- 1** Press the [Position] key.

- 2** Select the desired numbering position by pressing the \rightarrow key.

Note

- If you want to change the original orientation, press the [Original] key.

- 3** Press the [OK] key.

- 5** Press the [OK] key.

- 6** Press the [Exit] key.

Note

- When you set the original on the exposure glass, press the [#] key after all originals are scanned.

Combination Chart

The combination chart given below shows which modes can be used together. When you read the chart, please refer to the following table.

☆	means that these modes can be used together.
→	means that these modes cannot be used together. The mode after you select will be the mode you're working in.
×	means that these modes cannot be used together. The mode before you select will be the mode you're working in.

The following shows the combinations of functions.

	Mode after you select																										
	Non-standard Originals	Original Type Selection	Auto Paper Select	Auto Reduce/Enlarge	Sort	Rotate Sort	Shift Sort	Shift Stack	Staple	Copying From The Bypass Tray	Preset Reduce/Enlarge	Zoom	Directional Size Magnification (inch)	Directional Magnification (%)	Erase Center	Erase Border	Combine	Series Copies	Duplex	Cover	Preset Stamp	Page Numbering	OHP Slip Sheet	Positive/Negative	Image Repeat	Overlay	
Non-standard Originals	☆	☆	×	☆	☆	☆	☆	☆	☆	☆	☆	☆	☆	☆	☆	☆	☆	☆	☆	☆	☆	☆	☆	☆	☆	☆	☆
Original Type Selection	☆	☆	×	☆	☆	☆	☆	☆	☆	☆	☆	☆	☆	☆	☆	☆	☆	☆	☆	☆	☆	☆	☆	☆	☆	☆	☆
Auto Paper Select	×	☆	×	↓	☆	☆	☆	☆	☆	↓	☆	☆	☆	☆	☆	☆	↓	☆	☆	☆	↓	☆	☆	☆	☆	☆	☆
Auto Reduce/Enlarge	☆	×	×	↓	☆	☆	☆	☆	☆	×	↓	↓	↓	↓	☆	☆	☆	☆	☆	☆	↓	☆	☆	☆	☆	☆	☆
Sort	☆	☆	☆	☆	☆	↓	↓	↓	↓	☆	↓	↓	↓	↓	☆	☆	☆	☆	☆	☆	☆	☆	☆	☆	☆	☆	☆
Rotate Sort	☆	☆	☆	☆	↓	↓	↓	↓	↓	×	↓	↓	↓	↓	☆	☆	☆	☆	☆	☆	↓	☆	☆	☆	☆	☆	×
Shift Sort	☆	☆	☆	☆	↓	↓	↓	↓	↓	×	↓	↓	↓	↓	☆	☆	☆	☆	☆	☆	☆	↓	☆	☆	☆	☆	×
Shift Stack	☆	☆	☆	☆	↓	↓	↓	↓	↓	×	↓	↓	↓	↓	☆	☆	☆	☆	☆	☆	↓	☆	☆	☆	☆	☆	×
Staple	☆	☆	☆	☆	↓	↓	↓	↓	↓	×	↓	↓	↓	↓	☆	☆	☆	☆	☆	☆	☆	↓	☆	☆	☆	☆	×
Copying From The Bypass Tray	☆	☆	↓	×	×	×	×	×	×	↓	☆	☆	☆	☆	×	×	×	×	×	×	×	×	×	×	×	×	☆
Preset Reduce/Enlarge	☆	☆	☆	↓	☆	☆	☆	☆	☆	☆	↓	↓	↓	↓	☆	☆	↓	☆	☆	☆	☆	☆	☆	☆	☆	☆	☆
Zoom	☆	☆	☆	↓	☆	☆	☆	☆	☆	☆	↓	↓	↓	↓	☆	☆	↓	☆	☆	☆	☆	☆	☆	☆	☆	☆	☆
Directional Size Magnification (inch)	☆	☆	☆	↓	☆	☆	☆	☆	☆	☆	↓	↓	↓	↓	☆	☆	↓	☆	☆	☆	☆	☆	☆	☆	☆	☆	☆
Directional Magnification (%)	☆	☆	☆	↓	☆	☆	☆	☆	☆	☆	↓	↓	↓	↓	☆	☆	↓	☆	☆	☆	☆	☆	☆	☆	☆	☆	☆
Erase Center	☆	☆	☆	☆	☆	☆	☆	☆	☆	×	☆	☆	☆	☆	↓	↓	↓	↓	↓	↓	↓	↓	↓	↓	↓	↓	↓
Erase Border	☆	☆	☆	☆	☆	☆	☆	☆	☆	×	☆	☆	☆	☆	↓	↓	↓	↓	↓	↓	↓	↓	↓	↓	↓	↓	↓

Mode before you select		Mode after you select																	
		Combine						Series Copies						Duplex					
2 pages → 1-sided	1-sided	☆	☆	☆	☆	☆	☆	☆	☆	☆	☆	☆	☆	☆	☆	☆	☆	☆	☆
		☆	☆	☆	☆	☆	☆	☆	☆	☆	☆	☆	☆	☆	☆	☆	☆	☆	☆
4 pages → 1-sided	1-sided	☆	☆	☆	☆	☆	☆	☆	☆	☆	☆	☆	☆	☆	☆	☆	☆	☆	☆
		☆	☆	☆	☆	☆	☆	☆	☆	☆	☆	☆	☆	☆	☆	☆	☆	☆	☆
4 pages → 2-sided	2-sided	☆	☆	☆	☆	☆	☆	☆	☆	☆	☆	☆	☆	☆	☆	☆	☆	☆	☆
		☆	☆	☆	☆	☆	☆	☆	☆	☆	☆	☆	☆	☆	☆	☆	☆	☆	☆
8 pages → 1-sided	1-sided	☆	☆	☆	☆	☆	☆	☆	☆	☆	☆	☆	☆	☆	☆	☆	☆	☆	☆
		☆	☆	☆	☆	☆	☆	☆	☆	☆	☆	☆	☆	☆	☆	☆	☆	☆	☆
8 pages → 2-sided	2-sided	☆	☆	☆	☆	☆	☆	☆	☆	☆	☆	☆	☆	☆	☆	☆	☆	☆	☆
		☆	☆	☆	☆	☆	☆	☆	☆	☆	☆	☆	☆	☆	☆	☆	☆	☆	☆
2-sided → 1-sided	1-sided	☆	☆	☆	☆	☆	☆	☆	☆	☆	☆	☆	☆	☆	☆	☆	☆	☆	☆
		☆	☆	☆	☆	☆	☆	☆	☆	☆	☆	☆	☆	☆	☆	☆	☆	☆	☆
Book → 1-sided	1-sided	☆	☆	☆	☆	☆	☆	☆	☆	☆	☆	☆	☆	☆	☆	☆	☆	☆	☆
		☆	☆	☆	☆	☆	☆	☆	☆	☆	☆	☆	☆	☆	☆	☆	☆	☆	☆
1-sided → 2-sided	2-sided	☆	☆	☆	☆	☆	☆	☆	☆	☆	☆	☆	☆	☆	☆	☆	☆	☆	☆
		☆	☆	☆	☆	☆	☆	☆	☆	☆	☆	☆	☆	☆	☆	☆	☆	☆	☆
2-sided → 2-sided	2-sided	☆	☆	☆	☆	☆	☆	☆	☆	☆	☆	☆	☆	☆	☆	☆	☆	☆	☆
		☆	☆	☆	☆	☆	☆	☆	☆	☆	☆	☆	☆	☆	☆	☆	☆	☆	☆
Book → 2-sided	2-sided	☆	☆	☆	☆	☆	☆	☆	☆	☆	☆	☆	☆	☆	☆	☆	☆	☆	☆
		☆	☆	☆	☆	☆	☆	☆	☆	☆	☆	☆	☆	☆	☆	☆	☆	☆	☆
Cover		☆	☆	☆	☆	☆	☆	☆	☆	☆	☆	☆	☆	☆	☆	☆	☆	☆	☆
Preset Stamp		☆	☆	☆	☆	☆	☆	☆	☆	☆	☆	☆	☆	☆	☆	☆	☆	☆	☆
Page Numbering		☆	☆	☆	☆	☆	☆	☆	☆	☆	☆	☆	☆	☆	☆	☆	☆	☆	☆
OHP Slip Sheet		☆	☆	☆	☆	☆	☆	☆	☆	☆	☆	☆	☆	☆	☆	☆	☆	☆	☆
Positive/Negative		☆	☆	☆	☆	☆	☆	☆	☆	☆	☆	☆	☆	☆	☆	☆	☆	☆	☆
Image Repeat		☆	☆	☆	☆	☆	☆	☆	☆	☆	☆	☆	☆	☆	☆	☆	☆	☆	☆
Overlay		☆	☆	☆	☆	☆	☆	☆	☆	☆	☆	☆	☆	☆	☆	☆	☆	☆	☆
Interrupt		☆	☆	☆	☆	☆	☆	☆	☆	☆	☆	☆	☆	☆	☆	☆	☆	☆	☆

*1 When you select the mode after you select, the machine returns to Auto Reduce/Enlarge mode. However, you can select the mode before you select again.

3. What to do If Something Goes Wrong

If Your Machine does not Operate as You Want

Message

Machine's Condition	Problem/Cause	Action
The machine instructs you to wait.	The machine is warming up.	Wait for the machine to warm-up. 🔍 Reference You can use Auto Start mode during the warm-up period. See ⇒ P.48 "Auto Start—Entering Copy Job Settings During the Warm-up Period"
The machine cannot detect the original size.	Unsuitable original is set. See ⇒ P.17 "Sizes Difficult to Detect".	Set non-standard size original on the exposure glass.
		Input the both horizontal and vertical sizes of the non-standard original. See ⇒ P.27 "Setting Originals on the Exposure Glass".
		Select paper manually, not in Auto Paper Select mode.
	Do not use Auto Reduce/Enlarge mode.	
	Original is not set.	Set your originals.
The machine instructs you to check the original direction.	There is no copy paper that is the same direction as the originals.	Set the original in the same direction as the copy paper.
The machine instructs you to check paper size.	Unsuitable original size is set.	Select the proper paper size.
The machine cannot staple this size paper.	--	Select the proper paper size that can be used in Staple mode. See ⇒ P.38 "Staple"

Machine's Condition	Problem/Cause	Action
You cannot enter the desired copy set number.	The number of copies exceeds the maximum copy quantity.	You can change the maximum copy quantity that you can make at a time. See "05. Max. Copy Q'ty" in ⇒ P.117 "1. General Features 2/4"
The machine instructs you to set the duplex tray.	--	Reset the duplex tray correctly. See ⇒ P.5 "Guide to Components".
The machine instructs you to set the key counter.		Set the key counter.

Display

Problem	Cause	Action
The panel display is off.	The machine is in Energy Saver mode.	Press the [Energy Saver] key to cancel Energy Saver mode.
	The operation switch is turned off.	Turn on the operation switch.
	The main power switch is turned off.	Turn on the main power switch.
Nothing happens when the operation switch is turned on.	The main power switch is turned off.	Turn on the main power switch. See ⇒ P.5 "Guide to Components"
	The power cord is unplugged.	Make sure that the power cord is plugged into the wall outlet firmly.

If You Cannot Make Clear Copies

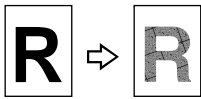
Problem	Cause	Action
Copies appear dirty.	The image density is too dark.	Adjust the image density. ⇒ P.30 "Adjusting Copy Image Density".
	Auto Image Density is not selected.	Select Auto Image Density.
The reverse side of an original image is copied.	The image density is too dark.	Adjust the image density. ⇒ P.30 "Adjusting Copy Image Density".
	Auto Image Density is not selected.	Select Auto Image Density.
A shadow appears on copies if you use the pasted originals.	The image density is too dark.	Adjust the image density. ⇒ P.30 "Adjusting Copy Image Density".
		Change the direction of the original.
		Put mending tape on the pasted part.
The same copy area is dirty whenever making copies.	The exposure glass, platen cover, or document feeder white sheet is dirty.	Clean them. ⇒ P.132 "Maintaining Your Machine".
Copies are too light.	The image density is too light.	Adjust the image density. ⇒ P.30 "Adjusting Copy Image Density".
	Damp or rough grain paper is used.	Use dry paper without rough grain.
	Toner cartridge is almost empty.	Add toner. ⇒ P.91 "Changing the Toner Bottle".
Parts of the image are not copied.	The original is not set correctly.	Set originals correctly. ⇒ P.27 "Setting Originals".
	An improper paper size is selected.	Select the proper paper size.
Copies are blank.	The original is not set correctly.	Set originals correctly. ⇒ P.27 "Setting Originals".
A moire pattern is produced on copies. 	Your original has a dot pattern image or many lines.	Change the original direction.

If You Cannot Make Copies as You Want

3

Problem	Cause	Action
Copies are not stapled.	There are jammed staples in the stapler.	Remove jammed staples. See ⇒ P.109 “ <i>e Removing Jammed Staples</i> ”. Note ❑ After removing jammed staples or adding staples, staples might not be ejected the first few times you try to use the stapler.
	The number of copies exceeds the capacity of the stapler.	Check the stapler capacity. See ⇒ P.38 “ <i>Staple</i> ”.
	The stapler has run out of staple.	Add staples. See ⇒ P.107 “ <i>d Adding Staples</i> ”.
Staples are wrongly positioned.	Originals are not set correctly.	Set originals correctly. See ⇒ P.38 “ <i>Staple</i> ”.
Misfeeds occur frequently.	Copy paper size setting is not correct.	Set the proper paper size. See ⇒ P.103 “ <i>Changing the Paper Size</i> ”.
You cannot combine several functions.	Selected functions cannot be used together.	Refer to the combination chart. See ⇒ P.80 “ <i>Combination Chart</i> ”.

Adjust Image

Problem	Cause	Action
In Center/Border mode, parts of the original image are not copied.	The margin is too wide.	Set a narrower margin with the user tools. See “01. Border Erase Width” in ⇒ P.121 “2. Adjust Image 1/3”. See “02. Center Erase Width” in ⇒ P.121 “2. Adjust Image 1/3”.
	Your original has narrow margins on four sides.	
In Image Repeat mode, the original image is not copied repeatedly.	You selected the same size copy paper as originals, and did not select the proper reproduction ratio.	Select copy paper larger than the originals. See ⇒ P.72 “Repeat Image—Repeating an Image over the Entire Copy”.
		Select the proper reproduction ratio. See ⇒ P.72 “Repeat Image—Repeating an Image over the Entire Copy”.

Combine

Problem	Cause	Action
Parts of the image are not copied.	You specified an improper reproduction ratio that does not meet the sizes of your originals and copy paper.	When you specify a reproduction ratio using Manual Paper Select mode, make sure the ratio matches your originals and the copy paper.  Note <input type="checkbox"/> Select the correct reproduction ratio before using Combine mode.
	Your originals are not identical in size and direction.	Use originals that are identical in size and direction.
Order of copies is not correct.	You set originals in the incorrect order.	When setting a stack of original in the document feeder, the last page should be on the bottom.
		If you set an original on the exposure glass, start with the first page to be copied.

Stamp

Problem	Cause	Action
Stamps do not appear on copies.	The original is not set correctly.	Set original correctly. See ⇒ P.75 "Preset Stamp—Printing Preset Messages on Your Copies".
Original image and stamp overlap on copies and original image cannot be read.	The stamp is set to solid.	Change to screen. See ⇒ P.127 "4 Stamp Setting 3/3".
	Your original has narrow margins on four sides.	Change the stamp position. See ⇒ P.127 "4 Stamp Setting 3/3".
Page numbers do not appear in the position you require.	The numbering position is wrong.	Change the numbering position. See ⇒ P.126 "4 Stamp Setting 2/3".

Duplex

3

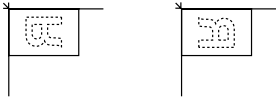
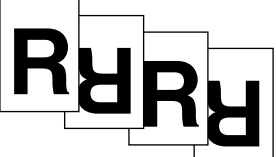
Problem	Cause	Action
Order of copies is not correct.	You set originals in the incorrect order.	<p>When setting a stack of originals in the document feeder, the last page should be on the bottom.</p> <p>If you set an original on the exposure glass, start with the first page to be copied.</p>
In Margin Adjustment mode, parts of the original image are not copied.	The margin is too wide.	Set a narrower margin with the user tools. See "03. Left Dup. Margin" in ⇒ P.121 "2. Adjust Image 1/3". See "04. Top Dup. Margin" in ⇒ P.121 "2. Adjust Image 1/3".
Orientation of copies (Top to Top, or Top to Bottom) is not correct.	You set originals in an incorrect direction or the orientation setting is incorrect.	<p>Select the correct orientation, or set originals correctly. ⇒ P.64 "Duplex—Making Two-Sided Copies"</p> <p> Note</p> <ul style="list-style-type: none"> <input type="checkbox"/> If you set A3, 11" × 17" or B4JIS, 8¹/₂" × 14" originals as shown below, for example, take one of the two actions described below the illustration. <div style="display: flex; justify-content: space-around; align-items: center;">  </div> <ul style="list-style-type: none"> <input type="checkbox"/> Select [Top to Bottom] to make copies in "Top to Top" orientation. Select [Top to Top] to make copies in "Top to Bottom" orientation. <input type="checkbox"/> Alternate the originals as shown below when setting them. 

Loading Paper

Note

- ❑ If you want to change the paper size, see ⇒ P.103 "Changing the Paper Size".

Reference

Regarding paper types and sizes that can be set, see ⇒ P.19 "Copy Paper".

- 1** Pull out the paper tray until it stops.

- 2** Square the paper and set it in the tray.

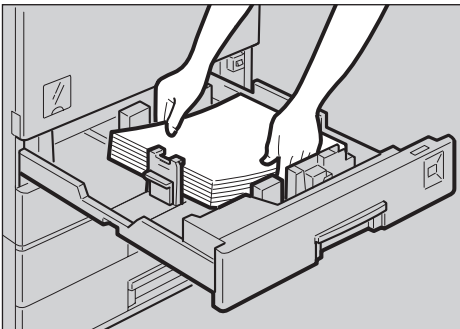

ZAAY070E

Important

- ❑ Do not stack paper over the limit mark.
- ❑ If paper is left in the paper tray and then you add paper, a mis-feed might occur.

Note

- ❑ Shuffle the paper before setting it in the tray.

Loading non-standard size paper in the tray 2

- 1** When you set the non-standard size paper in tray 2, do not stack the paper above the lower limit mark of tray 2.

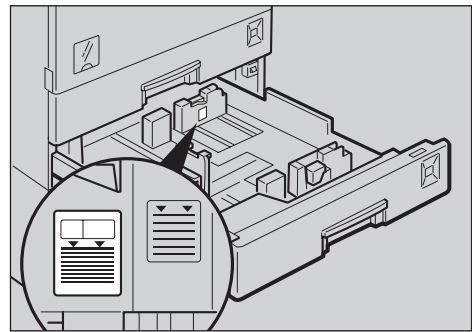

ZAAY140E

- 3** Reinstall the back fence.
- 4** Push the paper tray in until it stops.

Loading Paper in the Large Capacity Tray

Note

- ❑ Set copy paper of the same size and direction in the left side of the large capacity tray.

1 Pull out the large capacity tray.

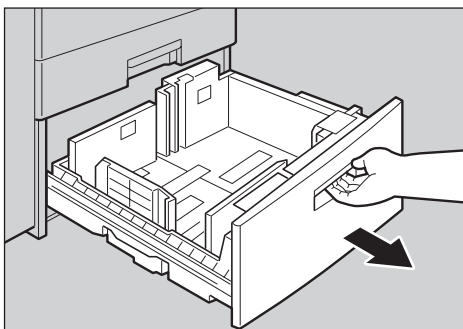

ZAA010E

2 Place the paper in the tray.

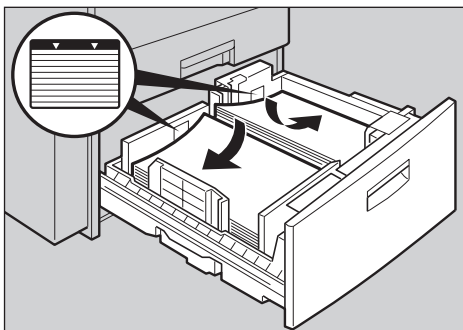

ZAA020E

Important

- ❑ Align the right edge of the right copy paper stack with the right edge of the tray.
- ❑ Align the left edge of the left copy paper stack with the left edge of the tray.
- ❑ Do not stack paper over the limit mark.

Note

- ❑ Shuffle the paper before setting it in the tray.
- ❑ If the paper is curled, set the paper up side down.

3 Push the tray in until it stops.

3

Changing the Toner Bottle

When  is displayed, it is time to supply toner.

⚠ WARNING:

- **Do not incinerate used toner or toner containers. Toner dust might ignite when exposed to an open flame. Dispose of used toner containers in accordance with local regulations for plastics.**

⚠ CAUTION:

- *Keep toner (used or unused) and toner containers out of reach of children.*

⚠ CAUTION:

- *Our products are engineered to meet high standards of quality and functionality, and we recommend that you only use the expendable supplies available at an authorized dealer.*

🔊 Important

- If you use toner other than that recommended, a fault might occur.
- When adding toner, do not turn off the power switch. If you do, your settings are cleared.
- Always add toner after the machine instructs you to add toner.

📌 Note

- You can still make about 50 copies after the  symbol is flashing, but replace the toner early to prevent poor copy quality.

🔍 Reference

Regarding toner storage, see ⇒ P.23 “Toner Storage”.

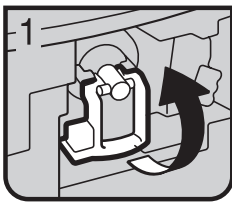

ZAAx040E

- 1: Open the front cover of the machine.
- 2: Lift the green holder.

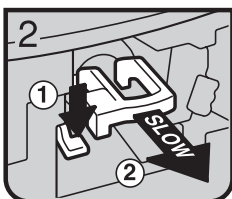

ZAAx050E

- 3: Push the green lever, and gently pull out the holder.

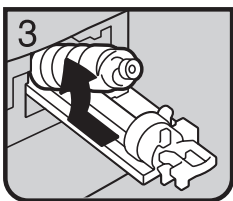

ZAAX060E

- 4: Press the toner bottle backward to raise its head, then gently pull out the bottle.

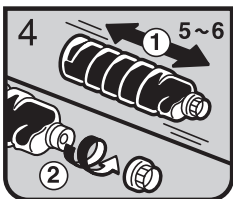

ZAAX070E

- 5: Hold the new bottle horizontally and shake it 5 or 6 times.

 **Note**

- Do not remove the black cap when shaking.

- 6: Remove the black cap.

 **Note**

- Do not remove the inner cap.

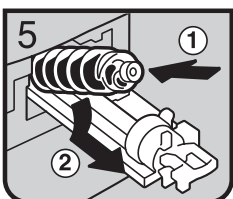

ZAAX080E

- 7: Put the toner bottle on the holder, then press its head forward.

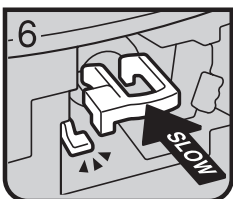

ZAAX090E

- 8: Push the holder until it clicks.

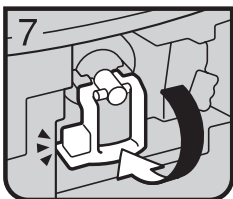

ZAAX100E

- 9: Push down the green holder.
- 10: Close the front cover of the machine.

Replacing Photo Conductor Unit (PCU)

When 'Replace photoconductor unit' appears on the panel display, it is time to replace the photo conductor unit.

⚠ **WARNING:**

- ***Do not incinerate the photoconductor unit. Toner dust might ignite when exposed to an open flame. Dispose of the used photoconductor unit in accordance with local regulations for plastics.***

📌 **Note**

- ❑ Do not tilt used PCU after removing it from the machine. If you do, toner might fall out.
 - ❑ Do not hold the developer cartridge when removing the used PCU from your machine. If you do, the cartridge might come unlocked and fall.
 - ❑ Do not touch the photo conductor. If you do, abnormal copies might be made.
 - ❑ Before you remove the used PCU from the machine, wait until the machine has completely stopped and is making no sound. Failure to take this precaution could result in a fault.
 - ❑ If there are misfeeds, remove the misfed paper before removing the used PCU.
 - ❑ Be sure to remove the sealing tape before setting the new PCU. Leaving it on could cause a fault.
 - ❑ After replacing the PCU, the machine will take about 1 minutes to initialize. During this period, do not open the front cover or turn off the main switch. If you do, a fault might occur.
- 1** If the duplex unit is installed, open the duplex unit by pushing the catch upwards.

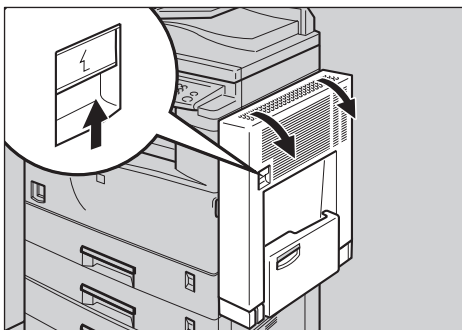

ZAAX270E

2 Open the right cover of the machine by pushing the catch upwards.

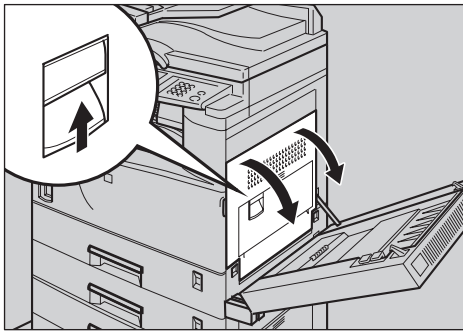

ZAAx280E

3

3 Open the front cover.

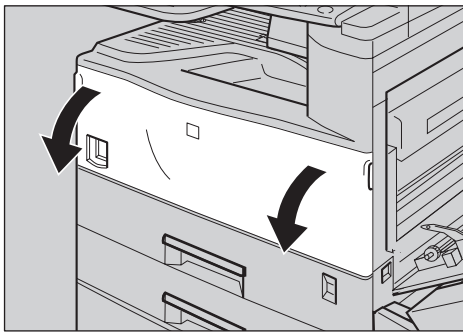

ZAAx290E

4 While pressing the green button, slide the photo conductor unit out until it stops.

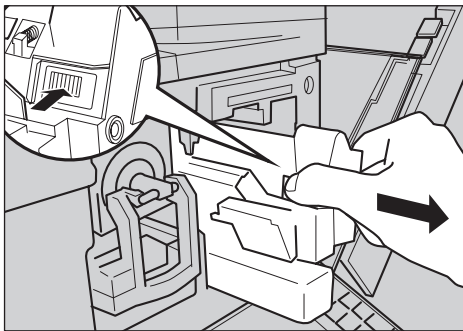

ZAAx300E

- 5** Raise the green handle and slide the photo conductor unit out towards you.

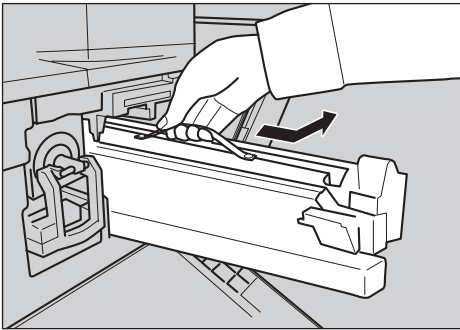

ZAAX310E

Important

- Do not tilt or drop the removed photo conductor unit. Moving the unit abruptly can scatter the toner.
- While the photo conductor unit is removed, do not change the toner.

- 6** Take the new photo conductor unit from the box and remove the plastic bag, holding the handle.

Important

- Do not drop or damage the removed photo conductor unit.
- Do not touch the side of the photo conductor unit.

- 7** Put the photo conductor unit removed in step **5** into the plastic bag emptied in step **6**, keeping the unit at the same angle as when it was installed. Then, zip the plastic bag.

Note

- Do not tilt the used PCU after Removing it from the machine. If you do, toner might fall.

- 8** Remove the two red sheets from the photo conductor unit in the order shown in the illustration.

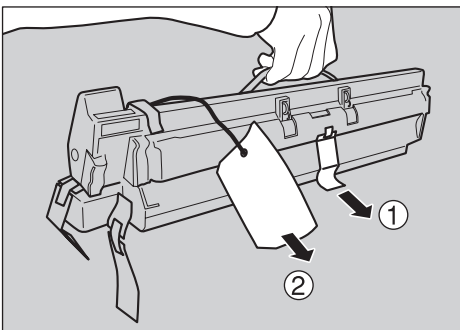

ZAAX320E

Important

- Remove the photo conductor unit keeping the unit parallel to the ground as shown in the illustration. Otherwise, the toner in the unit might scatter.
- Do not touch the inside of the unit or the green parts, after the black protection sheet is removed.

9 Align the new photo conductor unit onto the rail of the machine. Slide the unit all the way into the machine.

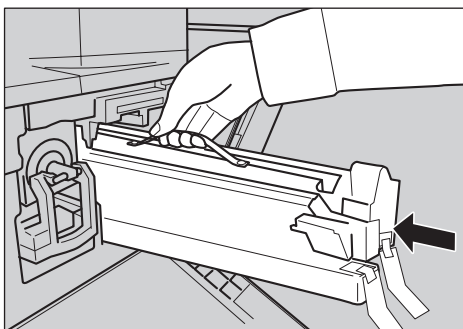

ZAAX330E

10 Push the unit into the machine until it clicks into place.

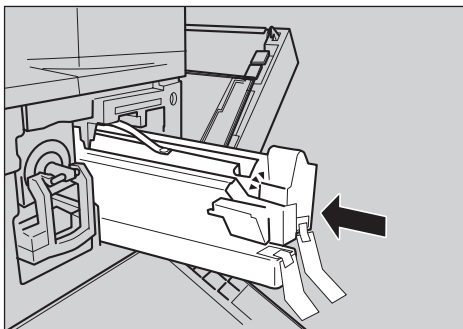

ZAAX340E

11 Remove the red sheet from the photo conductor unit and remove the two pieces of tape.

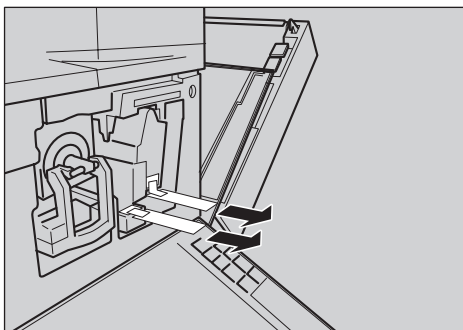

ZAAX350E

12 Close the right cover of the machine.

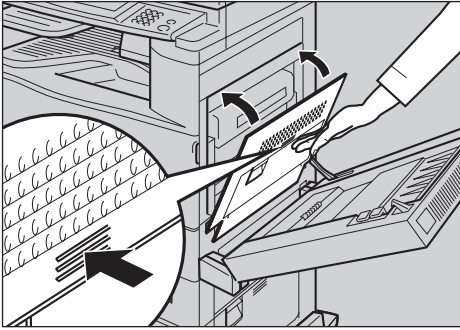

ZAAX360E

Note

- If the right side cover of the machine cannot be closed, it means that the photo conductor unit has not been properly installed. Slide the photo conductor unit out and push it into the machine again until it clicks into place.

13 Close the front cover.

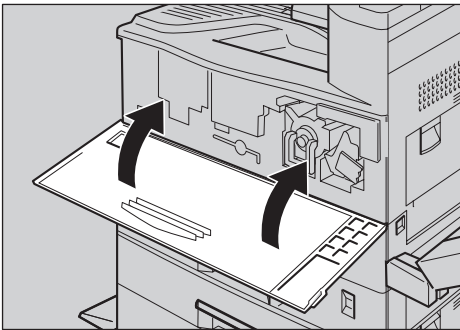

ZAAX370E

14 If the duplex unit is installed, close the duplex unit by pushing the catch upwards.

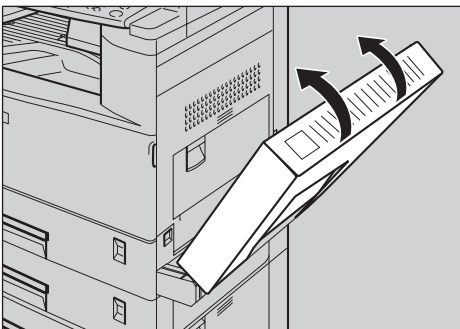

ZAAX380E

Note

- Confirm that the "Replace PCU" message does not appear on the Operation Panel.

Clearing Misfeeds

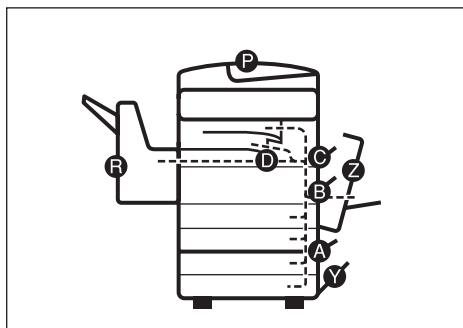

CAUTION:

- *The fusing section of this equipment might be very hot. You should be very careful that you don't touch this section when removing the misfed paper.*

Important

- When clearing misfeeds, do not turn off the power switch. If you do, your copy settings are cleared.
- To prevent misfeeds, do not leave any torn scraps of paper within the machine.
- If paper misfeeds occur repeatedly, contact your service representative.

Note

- More than one misfed areas may be indicated. In this case, check every applicable area. Refer to the following charts: A, B, C, D, R, P, Y, Z
- You can find a sticker explaining how to remove misfed paper inside of the front cover, upper side of the finisher.
- When the machine instructs you to reset originals, reset your originals to the feeding position. The display will indicate the number of originals you should return.

This page is intentionally blank.

■ When C is lit

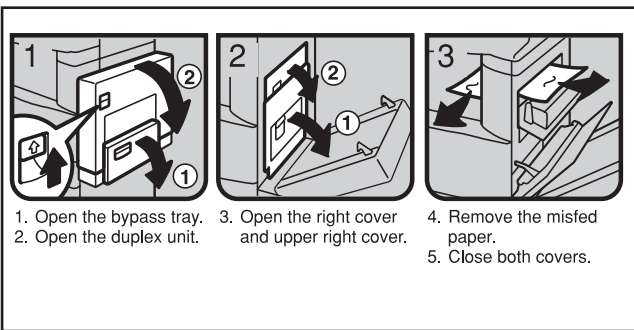

1. Open the bypass tray.
2. Open the duplex unit.
3. Open the right cover and upper right cover.
4. Remove the misfed paper.
5. Close both covers.

3

■ When D is lit

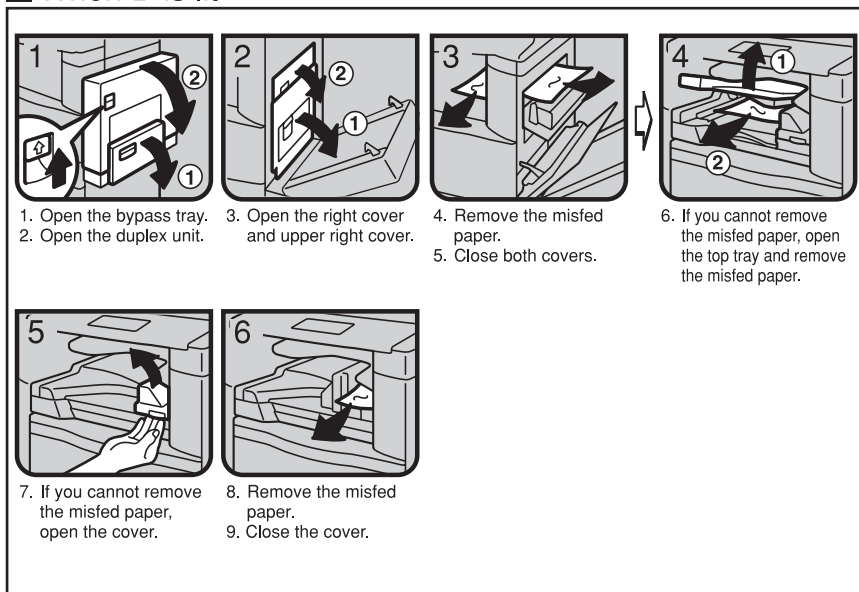

1. Open the bypass tray.
2. Open the duplex unit.
3. Open the right cover and upper right cover.
4. Remove the misfed paper.
5. Close both covers.
6. If you cannot remove the misfed paper, open the top tray and remove the misfed paper.
7. If you cannot remove the misfed paper, open the cover.
8. Remove the misfed paper.
9. Close the cover.

■ When B is lit

1. Open the bypass tray.
2. Open the duplex unit.
3. Open the right cover.
4. Remove the misfed paper.
5. Close the covers.
6. Push up the paper guide release lever and then remove the misfed paper.
7. Pull down the paper guide release lever and close the bypass tray.

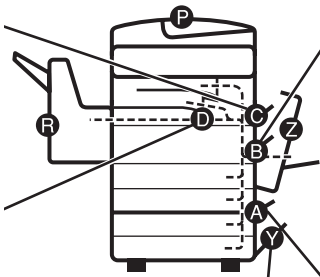

■ When Y is lit

1. Open the right cover.
2. Remove the misfed paper.
3. Close the cover.

■ When A is lit

1. Open the right cover of the paper tray unit.
2. Remove the misfed paper.
3. Close the cover.

ZAA020E

■ When P is lit

1. Open the cover of the document feeder and remove the misfed original.
2. Open the ADF external cover and remove the misfed original.
3. Open the document feeder.
4. Pull the green knob of upper left corner and remove misfed the original.

3

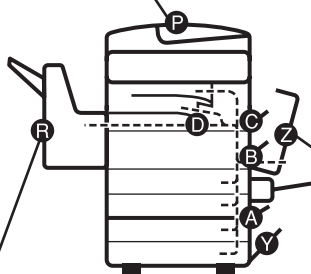

■ When R is lit

1. Remove the misfed paper.
2. If you cannot remove the misfed paper, open the top cover.
3. Remove the misfed paper.
4. If you cannot remove the misfed paper, pull out the front cover and remove the misfed paper.
5. Close the cover.

■ When Z is lit

1. Open the duplex unit.
2. Raise cover Z1 and remove the misfed paper.
3. If you cannot remove the misfed paper, raise cover Z2 and remove the misfed paper.
4. Close the unit.

ZAA030E

Changing the Paper Size

Preparation

Two procedures for changing the paper size are given below. The first is for changing the paper size in tray 1 or the optional paper table, the second for changing the paper size in tray 2. Please check you are following the appropriate procedure before you start.

Important

- Be sure to select the paper size with the user tools. Otherwise, misfeeds might occur.
- If you want to change the Large Capacity Tray's paper size, contact your service representative.

Reference

For paper sizes, weight, and capacity that can be set in each tray, see ⇒ P.19 "Copy Paper".

Changing the Paper Size in Tray 1 or the Optional Paper Table

- 1** Make sure that the paper tray is not being used.
- 2** Pull out the paper tray.

Note

- Remove any remaining copy paper.

- 3** While pressing the release lever, adjust the back fence.

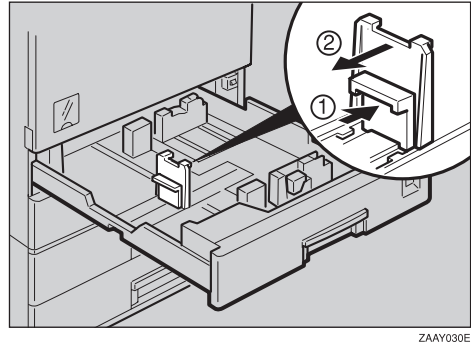

- 4** Release the side lever.

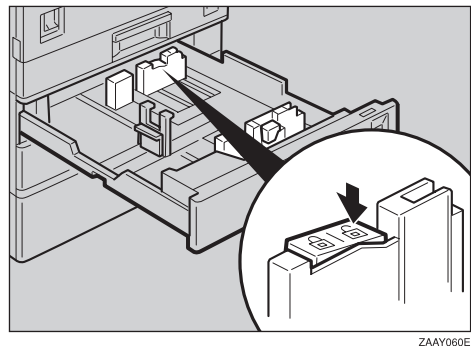

- 5** While pressing the release lever, adjust the side fences.

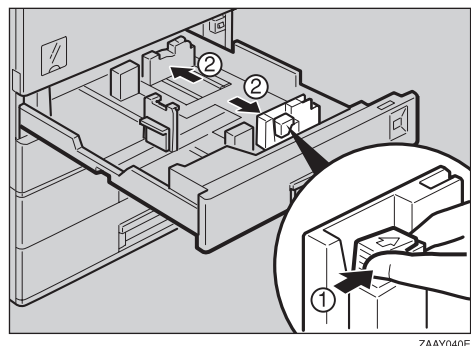

- 6** Square the paper and set it in the tray.

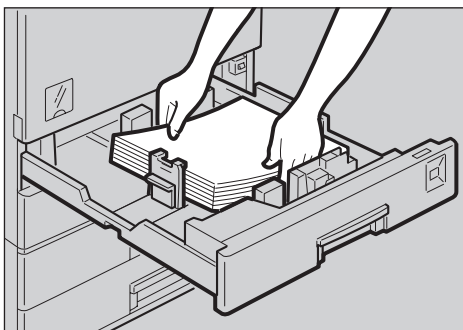

ZAA070E

- 9** While pressing the release lever, adjust the back fence to the new paper size.

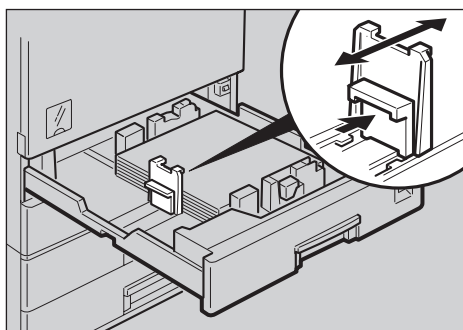

ZAA090E

Important

- Do not stack paper over the limit mark.

- 7** While pressing the release lever, adjust the side fences to the new paper size.

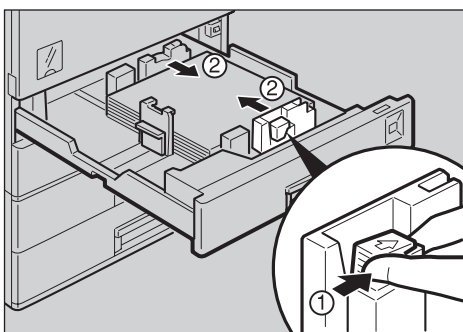

ZAA050E

Important

- When setting small quantities of copy paper, be careful not to squeeze in the side fence too much or paper will not be fed properly.

- 8** Lock the side lever.

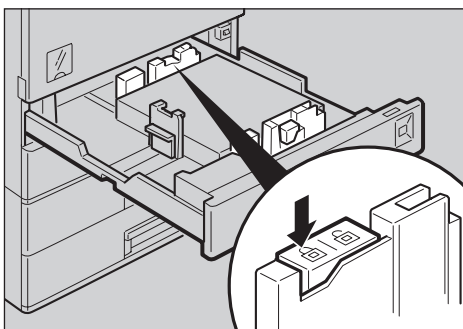

ZAA080E

- 10** Adjust the tray size with the paper size selector to the new paper size.

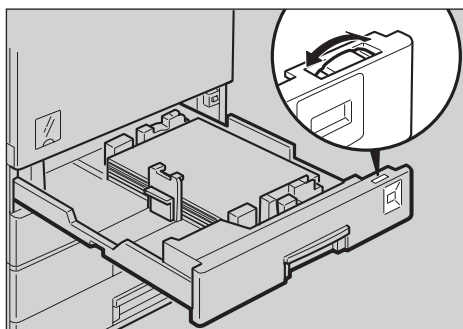

ZAA0100E

Note

- If you cannot find your desired paper size, select “*”, then set the copy paper size with the “11 Special Pap. Size” setting in the System Settings manual.

- 11** Push the paper tray in until it stops.

Changing the Paper Size in Tray 2

1 Carry out steps **1-10** described in "Changing the Paper Size in Tray 1 or the Optional Paper Table" ⇒ P.103 "Changing the Paper Size in Tray 1 or the Optional Paper Table".

Note

- If the size of paper you wish to load is not shown on the scale, slide the paper size selector to the "✖" mark then specify the paper size and type.

2 Push the switch-over lever to the left or right depending on the type of paper you have loaded:

Standard Paper

1 Push the switch-over lever to the left.

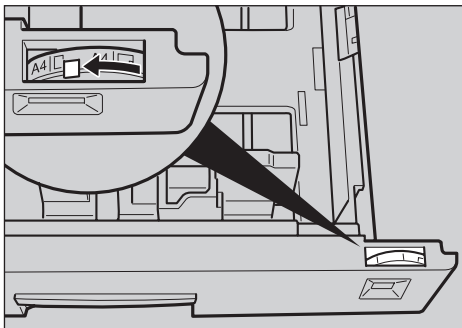

ZAAY130E

Non-standard Paper

e.g. OHP transparencies, transparent paper, postcards etc.

1 Push the switch-over lever to the right.



ZAAY120E

Note

- When you push the switch-over lever to the right, you cannot use the following functions.
 - Sort/Stack/Staple
 - Duplex

3 Push the paper tray in until it stops.

Setting the non-standard size paper

1 Press the **▶** key to select the second paper tray. Then press the **[#]** key.

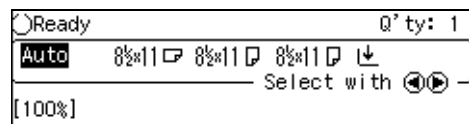

2 Press the **[Pap.Size]** key.

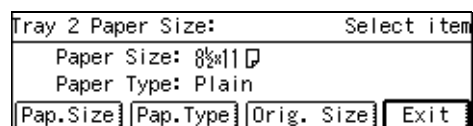

3 Press the [↑Prev.] or [↓Next] key until the page with the paper size you require is displayed.

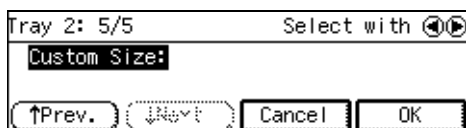
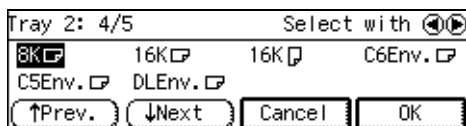
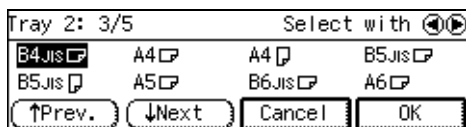
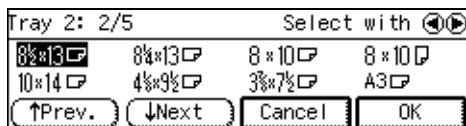
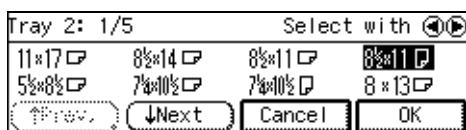

When the paper size you require is displayed

1 Press the [←] or [→] key to select the paper size. Then press the [OK] key.

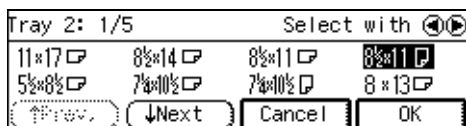

When the paper size you require is not displayed

Note

□ You can also specify the tray2 size with the User Tools (System Settings). See “11. Special Pap. Size” in the System Settings Reference.

1 When [Custom Size] screen is shown, press the [OK] key.

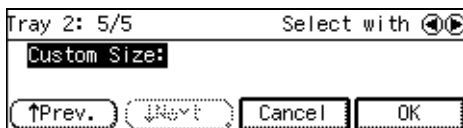

2 Enter the horizontal size then press the [#] key.

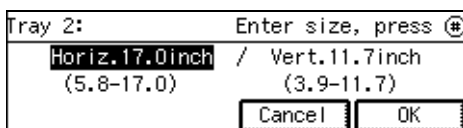

3 Enter the vertical size then press the [OK] key.

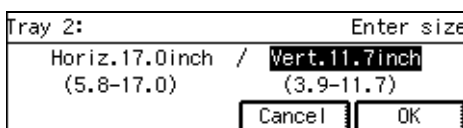

4 Press the [Pap.Type] key.

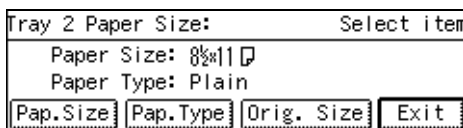

5 Press the [←] or [→] key to select the paper type. Then press the [OK] key.

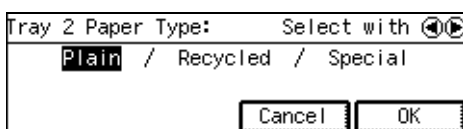

6 Press the [Exit] key.

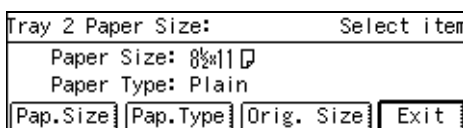

Adding Staples

CAUTION:

- Our products are engineered to meet high standards of quality and functionality, and we recommend that you only use the expendable supplies available at an authorized dealer.

Important

- ☐ If you use a staple cartridge other than that recommended, staple failure or staple jams might occur.

3

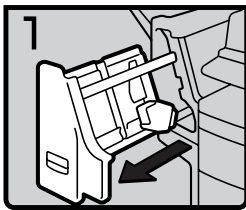

fin101EE

- 1: Open the front cover.

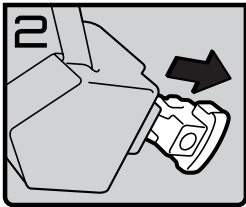

fin102EE

- 2: Remove the cartridge.

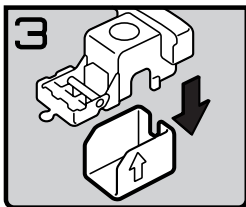

fin103EE

- 3: Take out the empty refill in the arrow direction.

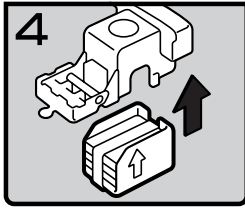

fin104EE

- 4: Push in the new refill until it clicks.

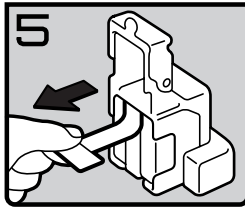

fin105EE

- 5: Pull out the ribbon.

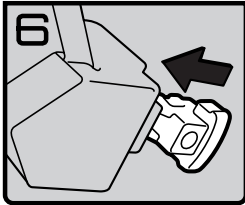

fin106EE

- 6: Reinstall the cartridge.

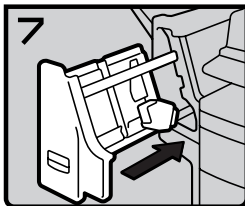

fin107EE

- 7: Close the front cover.

Removing Jammed Staples

Note

- ❑ Staples might be jammed because of curled copies. In this case, try turning the copy paper over in the tray. If there is no improvement, change to copy paper with less curl.
- ❑ After removing jammed staples, staples might not be ejected the first few times you try to use the stapler.

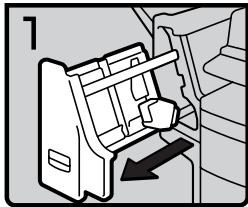

fin108EE

- 1: Open the front cover.

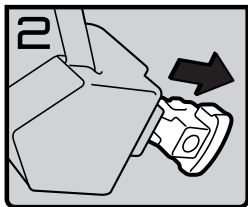

fin109EE

- 2: Remove the cartridge.

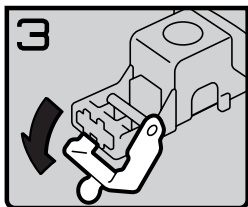

fin110EE

- 3: Open the face plate.

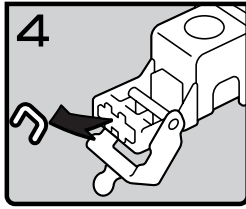

fin111EE

- 4: Remove the jammed staples.

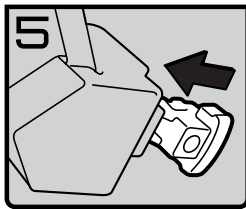

fin112EE

- 5: Reinstall the cartridge.

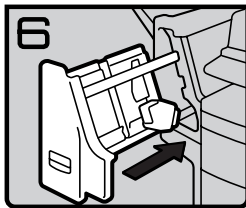

fin113EE

- 6: Close the front cover.

4. User Tools (Copy Features)

Accessing the User Tools (Copy Features)

This section is for the key operators in change of this machine. The user tools allow you to change or set the machine's default settings.

Preparation

Always exit the user tools when you have finished.

Reference

For how to access the system settings, see "Accessing The User Tools (System Settings)" in the System Settings Reference.

For information the Fax user tools, see the Fax Reference.

1 Press the **[User Tools/Counter]** key.

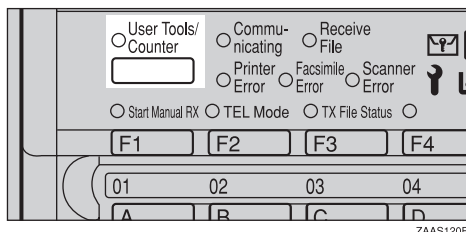

2 Enter **[2]** with the Number keys.

Note

- If you press the **[Language]** key, you can select the display language.

3 Enter the number of the desired User Tools menu with the Number keys.

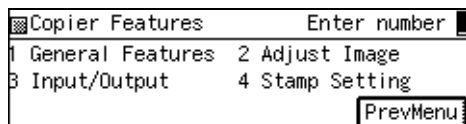

Note

- To return to the previous menu, press the **[PrevMenu]** key.

4 Search for the desired setting with the **[↓Next]** key. Enter its number with the Number keys.

Note

- [↓Next]** : Press to go to the next page.
- [↑Prev.]** : Press to go back to the previous page.

Reference

See ⇒ P.111 "User Tools (Copy Features)".

5 Change the settings by following the instructions on the panel display. Then press the **[OK]** key.

Reference

See ⇒ P.116 "Settings You Can Change with the User Tools".

Note

- [OK]** key: Press to set the new settings and return to the previous menu.
- [Cancel]** key: Press to return to the previous menu without changing any data.

Exiting the User Tools

1 Press the **[User Tools/Counter]** key.

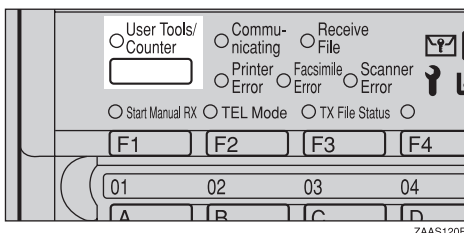

Note

- You can exit the User Tools by pressing the **[Exit]** key on the User Tools Main Menu.
- If you want to return to copy mode, press the **[User Tools/Counter]** key.
- The settings are not canceled even if the power switch is turned off or the **[Clear Modes]** key is pressed.

This page is intentionally blank.

User Tools Menu (Copier Features)

4

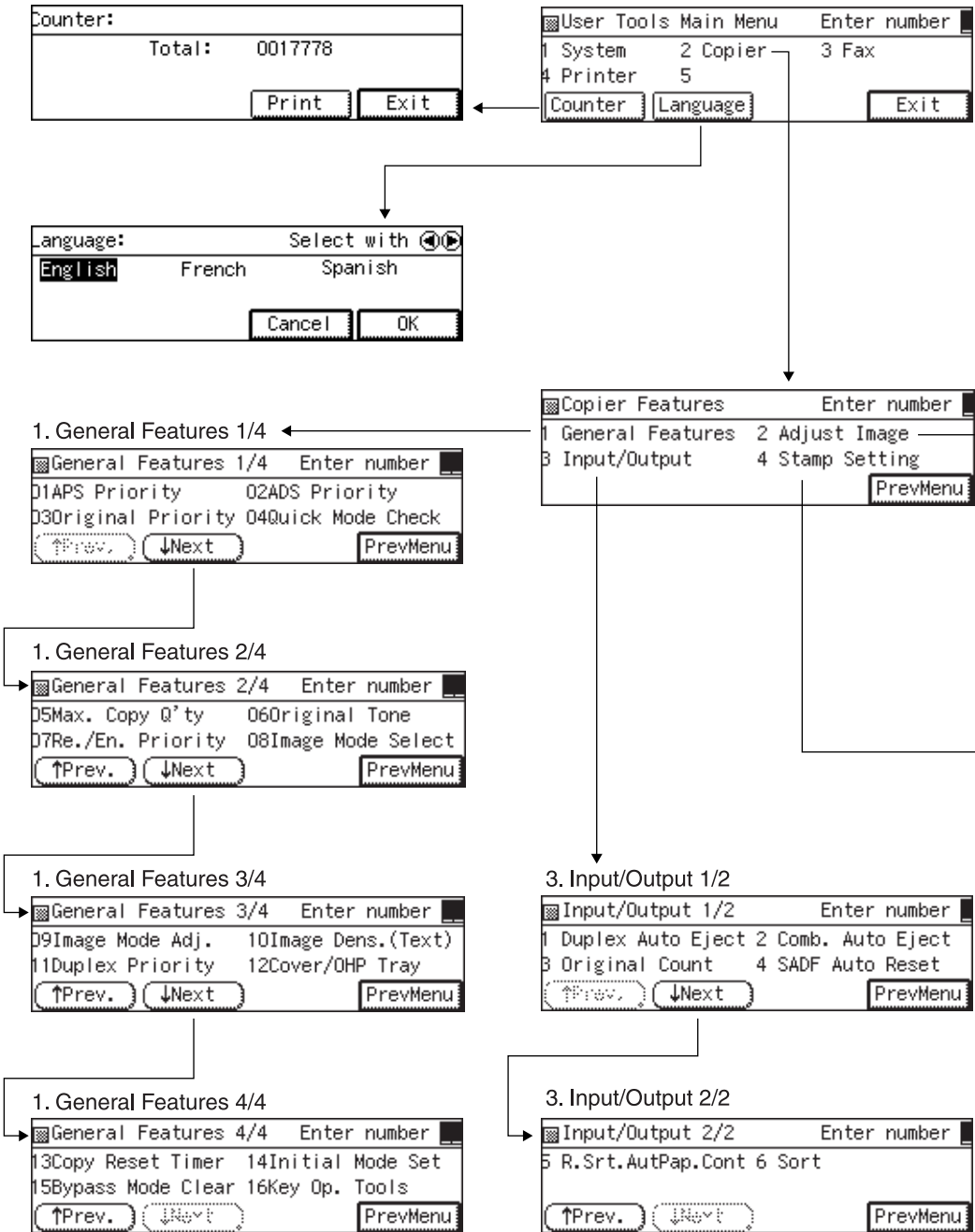

ZAAX050N

2. Adjust Image 1/2

Adjust Image 1/2	Enter number
1 Border EraseWidth	2 Center EraseWidth
3 Left Dup. Margin	4 Top Dup. Margin
↑Prev.	↓Next
PrevMenu	

2. Adjust Image 2/2

Adjust Image 2/2	Enter number
5 Line (Combine)	6 Line (Repeat)
↑Prev.	↓Next
PrevMenu	

4. Stamp Setting 1/3

Stamp Setting 1/3	Enter number
01Page No. Priority	02Page No. Size
03Dup.Back Page No.	04Page No. (Combine)
↑Prev.	↓Next
PrevMenu	

4. Stamp Setting 2/3

Stamp Setting 2/3	Enter number
05Page No. Position	06Page No. Adjust
07Stamp Priority	08Stamp Size
↑Prev.	↓Next
PrevMenu	

4. Stamp Setting 3/3







Stamp Setting 3/3	Enter number
09Stamp Density	10Stamp Position
11Stamp Adjustment	12Stamp Page Prio.
↑Prev.	↓Next
PrevMenu	

Settings You Can Change with the User Tools





Reference

For how to access the user tools, see ⇒ P.111 “Accessing the User Tools (Copy Features)”.





1. General Features ¹/₄





Menu	Description
01. APS Priority	<p>As a default setting, Auto Paper Select is selected. You can cancel this setting.</p> <p> Note <input type="checkbox"/> Default: <i>On</i></p>
02. ADS Priority	<p>In Text, Text/Photo and Photo modes, you can specify whether to select Auto Image Density.</p> <p> Note <input type="checkbox"/> Default:</p> <ul style="list-style-type: none"> • Text: <i>On</i> • Text/Photo: <i>On</i> • Photo: <i>Off</i>
03. Original Priority	<p>As a default setting, Text is selected as original type. You can change it to Text/Photo, or Photo.</p> <p> Note <input type="checkbox"/> Default: <i>Text</i></p>
04. Quick Mode Check	<p>You can specify whether the selected functions are shown on the initial display. If you change the default setting to [On], the display is shown as below.</p> <div style="border: 1px solid black; padding: 5px; width: fit-content; margin: 10px auto;"> <p>Ready Q'ty: 1</p> <p>Auto 8%*11 <input type="checkbox"/> 11*17 <input type="checkbox"/> 8%*11 <input checked="" type="checkbox"/> ↓</p> <p style="text-align: center;">Select with  </p> <p>[100%] Sort/Staple, C/B Erase</p> </div> <p> Note <input type="checkbox"/> Default: <i>Off</i></p>

1. General Features ²/₄



Menu	Description
05. Max. Copy Q'ty	<p>The maximum copy quantity can be set between 1 and 99.</p> <p> Note</p> <p><input type="checkbox"/> Default: 99</p>
06. Original Tone	<p>The key tone sounds when you forgot to remove originals after copying.</p> <p> Note</p> <p><input type="checkbox"/> Default: <i>On</i></p> <p><input type="checkbox"/> If the Panel Tone setting is set to Off, (see “System Settings”), the key tone does not sound irrespective Original Tone setting.</p>
07. Re./En. Priority	<p>Specify which Reduce, Enlarge or Input Ratio is shown on the panel display with priority when the [Reduce/Enlarge] key is pressed.</p> <p> Note</p> <p><input type="checkbox"/> Default:</p> <ul style="list-style-type: none"> • Metric version: 71 % • Inch version: 73 %
08. Image Mode Select	<p>You can select the copy quality.</p> <p> Limitation</p> <p><input type="checkbox"/> In Enhanced mode, the optional 48MB copier memory unit is required to use the sort function.</p> <p> Note</p> <p><input type="checkbox"/> Default: <i>Normal Mode</i></p>







1. General Features ^{3/4}

Menu	Description
09. Image Mode Adj. (when 08. Image Mode Select is set to Enhance mode)	Use to fine-tune the finish of copies for each original type setting (Text, Text/Photo, Photo)
1 Text	Use to adjust the cut of edges in the final image.  Note <input type="checkbox"/> Applied when the Original Type indicator is lit, and Text is selected.
2 Text/Photo	When your document contains a mixture of text and photographs, this settings adjusts which of the two take priority in the final image.  Note <input type="checkbox"/> Applies when Text/Photo has been selected with [Original Type] key.
3 Photo	Choose a setting that matches the type of photographic original you are copying.  Note <input type="checkbox"/> Applies when Photo has been selected with the [Original Type] key. <input type="checkbox"/> Coarse Print: Printed photographs are rendered using coarse dots. <input type="checkbox"/> Press Print: Printed photographs are rendered using fine dots. <input type="checkbox"/> Glossy Photo: For original photographs with a fine level gradation.
09. Image Mode Adj. (when 08. Image Mode Select is set to Normal mode)	Use to fine-tune the finish of copies for each original type setting (Text, Text/Photo, Photo)
1 Text	Use to adjust the cut of edges in the final image.  Note <input type="checkbox"/> Applies when the Original Type indicator is lit, and Text is selected.
2 Text/Photo	When your document contains a mixture of text and photographs, this settings adjusts which of the two take priority in the final image.  Note <input type="checkbox"/> Applies when Text/Photo has been selected with [Original Type] key.







Menu	Description
3 Photo	<p>Choose a setting that matches the type of photographic original you are copying.</p> <p> Note</p> <ul style="list-style-type: none"> <input type="checkbox"/> Applies when Photo has been selected with the [Original Type] key. <input type="checkbox"/> Glossy Photo: Renders printed photographs using large dots like that of a newspaper. <input type="checkbox"/> Coarse Print: Renders printed photographs coarsely, similar to gravure printing. <input type="checkbox"/> Glossy Photo: For original photographs with a fine level gradation.
10. Image Dens. (Text)	<p>You can select original text density setting level.</p> <p> Note</p> <ul style="list-style-type: none"> <input type="checkbox"/> Default: <i>Normal</i>
11. Duplex Priority	<p>You can select the type of the Duplex function to be effective when the machine is turned on, Energy Saver mode is off, or Copy Reset Timer is on.</p> <p> Note</p> <ul style="list-style-type: none"> <input type="checkbox"/> Default: <i>Off</i>
12. Cover/OHP Tray	<p>You can select a special tray for cover and OHP.</p> <p> Note</p> <ul style="list-style-type: none"> <input type="checkbox"/> Default: <i>Bypass</i>

1. General Features ⁴/₄







Menu	Description
13. Copy Reset Timer	<p>The machine returns to its initial condition automatically after your job is finished. The time can be set from 10 to 999 seconds, or Off.</p> <p> Note</p> <ul style="list-style-type: none"> <input type="checkbox"/> Default: <i>60 sec.</i>
14. Initial Mode Set	<p>You can select the initial mode or Program No. 10 as the mode to be effective when modes are cleared.</p> <p> Note</p> <ul style="list-style-type: none"> <input type="checkbox"/> Default: <i>Standard</i>
15. Bypass Mode Clear	<p>Specify whether to clear the bypass tray settings when the machine is turned on, Energy Saver mode is off, or the Copy Reset Timer times out.</p> <p> Note</p> <ul style="list-style-type: none"> <input type="checkbox"/> Default: <i>Off</i>







Menu	Description
<p>16. Key Op. Tools</p> <p>If the machine is set to use the User Code function, operators must input their user codes before the machine can operate.</p> <p>The machine can keep count of the number of copies made under each user code.</p>	
<p>1. User Code Mgmt.</p>	<p>Specify whether to employ user codes to restrict copier users and manage the number of copies made.</p> <p> Note</p> <p><input type="checkbox"/> Default: <i>Off</i></p>
<p>2. Counter Reset</p>	<p>You can check the number of copies made under each user code. You can also reset each user code's counter to 0.</p> <p> Note</p> <p><input type="checkbox"/> If more than one user code is registered, you can view all the counters using the [↑Prev.] or [↓Next] key.</p>
<p>3. Clear Code/Counter</p>	<p>You can delete all user codes or reset all counters to 0.</p>
<p>4. Prog. User Code</p>	<p>You can register user codes.</p> <p> Note</p> <p><input type="checkbox"/> Up to 50 user codes (8 digits or less) can be registered.</p>
<p>5. Chg/Del User Code</p>	<p>You can change or delete user codes.</p> <p> Note</p> <p><input type="checkbox"/> The number of copies made under the old code is added to that made under the new user code.</p> <p><input type="checkbox"/> The number of copies made under the deleted code is also deleted.</p>
<p>6. Counter List Print</p>	<p>You can print a list of counters shown by user code.</p> <p> Limitation</p> <p><input type="checkbox"/> If A4, 8¹/₂" × 11" or larger paper is not set in the paper trays, this list cannot be printed.</p> <p> Note</p> <p><input type="checkbox"/> To stop the printing, press the [Cancel] key.</p>

2. Adjust Image ¹/₃







Menu	Description
01. Border Erase Width	<p>The default width of erased margins in Border Erase mode can be changed as follows:</p> <ul style="list-style-type: none"> • Metric version: 3 – 50mm in 1mm steps • Inch version: 0.1 – 2.0" in 0.1" steps <p> Note</p> <p><input type="checkbox"/> Default:</p> <ul style="list-style-type: none"> • Metric version: <i>10mm</i> • Inch version: <i>0.4"</i>
02. Center Erase Width	<p>The default width of erased margins in Center Erase mode can be changed as follows:</p> <ul style="list-style-type: none"> • Metric version: 3 – 50mm in 1mm steps • Inch version: 0.1 – 2.0" in 0.1" steps <p> Note</p> <p><input type="checkbox"/> Default:</p> <ul style="list-style-type: none"> • Metric version: <i>10mm</i> • Inch version: <i>0.4"</i>
03. Left Dup. Margin	<p>You can specify left margin on the back side of copies.</p> <ul style="list-style-type: none"> • Metric version: 0 – 50mm in 1mm steps • Inch version: 0 – 2.0" in 0.1" steps <p> Limitation</p> <p><input type="checkbox"/> The optional duplex unit is required.</p> <p> Note</p> <p><input type="checkbox"/> Default:</p> <ul style="list-style-type: none"> • Metric version: <i>5mm</i> • Inch version: <i>0.2"</i>
04. Top Dup. Margin	<p>You can specify back top margin on the front side of copies.</p> <ul style="list-style-type: none"> • Metric version: 0 – 50mm in 1mm steps • Inch version: 0 – 2.0" in 0.1" steps <p> Limitation</p> <p><input type="checkbox"/> The optional duplex unit is required.</p> <p> Note</p> <p><input type="checkbox"/> Default:</p> <ul style="list-style-type: none"> • Metric version: <i>5mm</i> • Inch version: <i>0.2"</i>

2. Adjust Image ²/₃



Menu	Description
05. Line (Combine)	<p>You can select a type of separation line in Combine mode from None, Solid line, Broken 1, Broken 2, or Crop Marks.</p> <ul style="list-style-type: none"> • None <div style="text-align: center; margin: 5px 0;"></div> • Solid <div style="text-align: center; margin: 5px 0;"></div> • Broken 1 <div style="text-align: center; margin: 5px 0;"></div> • Broken 2 <div style="text-align: center; margin: 5px 0;"></div> • Crop Marks <div style="text-align: center; margin: 5px 0;"></div> <p> Note <input type="checkbox"/> Default: <i>None (no line)</i></p>

Menu	Description
06. Line (Repeat)	<p>You can select a type of separation line in Image Repeat mode from None, Solid, Broken 1, Broken 2, or Crop Marks.</p> <ul style="list-style-type: none"> • None <div style="text-align: center; margin: 5px 0;"></div> • Solid <div style="text-align: center; margin: 5px 0;"></div> • Broken 1 <div style="text-align: center; margin: 5px 0;"></div> • Broken 2 <div style="text-align: center; margin: 5px 0;"></div> • Crop Marks <div style="text-align: center; margin: 5px 0;"></div> <p> Note <input type="checkbox"/> Default: <i>None (no line)</i></p>

3. Input/Output ¹/₂





Menu	Description
1. Duplex Auto Eject	<p>When making two-sided copies from one-sided originals, if the last original is an odd page, the last copy will be automatically delivered with the reverse side blank. You can cancel this setting. ⇒ P.64 “<i>Duplex—Making Two-Sided Copies</i>”</p> <p> Limitation</p> <ul style="list-style-type: none"> <input type="checkbox"/> The optional duplex unit is required. <p> Note</p> <ul style="list-style-type: none"> <input type="checkbox"/> When you set one original at a time in the document feeder or set an original on the exposure glass, this function does not come effect. <input type="checkbox"/> Default: <i>On</i>
2. Comb. Auto Eject	<p>As a default setting, if the number of originals in the optional document feeder is less than the number required in the selected Combine mode, the missing image are copied blank. You can cancel this setting. ⇒ P.58 “<i>Combine—Combining Originals into One Copy</i>”</p> <p> Limitation</p> <ul style="list-style-type: none"> <input type="checkbox"/> When you set one original at a time in the document feeder or set an original on the exposure glass, this function does not come into effect. <p> Note</p> <ul style="list-style-type: none"> <input type="checkbox"/> Default: <i>On</i>
3. Original Count	<p>As a default setting, the display shows the copy quantity you specified and the number of copies made. You can cancel this setting, and instead view the number of originals to be fed in the document feeder and the number of copies made.</p> <p> Note</p> <ul style="list-style-type: none"> <input type="checkbox"/> Default: <i>Off</i>
4. SADP Auto Reset	<p>When you set one original at a time in the optional document feeder, the Auto Feed indicator lights for a selected time after an original is fed to show that the document feeder is ready for another original. You can adjust this time from 3 seconds to 99 seconds in 1 second steps.</p> <p> Limitation</p> <ul style="list-style-type: none"> <input type="checkbox"/> The optional document feeder (ADF) is required. <p> Note</p> <ul style="list-style-type: none"> <input type="checkbox"/> Default: <i>4 seconds</i>

3. Input/Output ²/₂







Menu	Description
5. R. Srt. AutPap. Cont	<p>If you select [Off] when the paper tray in use runs out of paper, the machine stops allowing you to add paper to the tray so you can have all the copies rotate-sorted.</p> <p> Note <input type="checkbox"/> Default: <i>Off</i></p>
6. Sort	<p>You can select a Sort function. ⇒ P.35 “Sort—Sorting into Sets (123, 123, 123)”</p> <p> Limitation <input type="checkbox"/> The optional finisher is required to use the Shift Sort function.</p> <p> Note <input type="checkbox"/> Default:</p> <ul style="list-style-type: none"> • Machine with finisher or shift sort tray: <i>Shift Sort</i> • Machine without finisher or shift sort tray: <i>Rotate Sort</i>

4





4 Stamp Setting ¹/₃

Menu	Description
01. Page No. Priority	<p>You can select the type of Page number priority.</p> <p> Note <input type="checkbox"/> Default: <i>P1, P2...</i></p>
02. Page No. Size	<p>You can select the size of page numbers.</p> <p> Note <input type="checkbox"/> Default: <i>Auto</i></p>
03. Dup. Back Page No.	<p>When making Duplex copies (Top to Top), you can select the position of page numbers on the back side of copies.</p> <p> Note <input type="checkbox"/> Default: <i>Left Side</i></p>
04. Page No. (Combine)	<p>When making Combine copies, you can select numbering per original or per copy.</p> <p> Note <input type="checkbox"/> Default: <i>Per Original</i></p>

4 Stamp Setting ²/₃

Menu	Description
05. Page No. Position	<p>You can select the position of page numbers for each Stamp mode.</p> <p> Note</p> <p><input type="checkbox"/> Default:</p> <ul style="list-style-type: none"> • P1, P2...: <i>Top Right</i>  • 1/5, 2/5...: <i>Top Right</i>  • -1-, -2-...: <i>Bottom Center</i> 
06. Page No. Adjust	<p>When you print page numbers on the top right, you can adjust the position in the range 0–50mm, 0–2.0 inch in 1mm, 0.1 inch steps.</p> <p> Note</p> <p><input type="checkbox"/> Default:</p> <ul style="list-style-type: none"> • Top: <i>0mm, 0.0"</i> • Right: <i>0mm, 0.0"</i>
07. Stamp Priority	<p>You can select the type of Stamp priority.</p> <p> Note</p> <p><input type="checkbox"/> Default: <i>CONFIDENTIAL</i></p>
08 Stamp Size	<p>You can select the size of the stamp.</p> <p> Note</p> <p><input type="checkbox"/> Default: <i>1x</i></p>

4 Stamp Setting ³/₃

Menu	Description
09. Stamp Density	<p>You can select the stamp density.</p> <p> Note</p> <p><input type="checkbox"/> Default: <i>Screen</i></p>
10. Stamp Position	<p>You can select the position of the stamp.</p> <p> Note</p> <p><input type="checkbox"/> Default: <i>Top</i> </p>
11 Stamp Adjustment	<p>When you print the stamp, you can adjust the position in the range 0–50mm, 0 – 2.0 inch in 1mm, 0.1 inch steps. This setting is valid for all types of stamps.</p> <p> Note</p> <p><input type="checkbox"/> Default:</p> <ul style="list-style-type: none"> • Top: <i>0mm, 0.0"</i> • Right: <i>0mm, 0.0"</i>
12 Stamp Page Prio.	<p>You can select the stamp page priority.</p> <p> Note</p> <p><input type="checkbox"/> Default: <i>All Pages</i></p>

5. Remarks

Do's and Don'ts

⚠ CAUTION:

- *Unplug the power cord from the wall outlet before you move the equipment. While moving the equipment, you should take care that the power cord will not be damaged under the equipment.*

🔊 Important

- Make sure the remaining memory space is 100%, before you unplug the power cord.
- While the machine is unplugged, you can neither send nor receive a fax.

🔍 Reference

For details, see the Facsimile Reference.

- Do not touch areas on or around the fusing unit. These areas get hot.
- After making copies continuously, you may feel the exposure glass is heated. This is not a malfunction.
- You may feel warm around the ventilation hole. This is caused by exhaust air, and is not a malfunction.
- Do not turn off the operation switch while copying or printing. When turning off the operation switch, make sure that copying or printing is completed.
- The machine might fail to produce good copy images if condensation forms inside the machine due to temperature change.
- Do not open the covers of the machine while copying or printing. If you do, misfeeds might occur.
- Do not move the machine while copying or printing.
- If you operate the machine improperly or a failure occurs, your settings might be lost. Be sure to take a note of your machine settings.
- Supplier shall not be liable for any loss or damages resulting from a failure on the machine, loss of machine settings, and use of the machine.
- Do not touch the Allen key if it is stored in the inner front cover. It is used by your service representative.

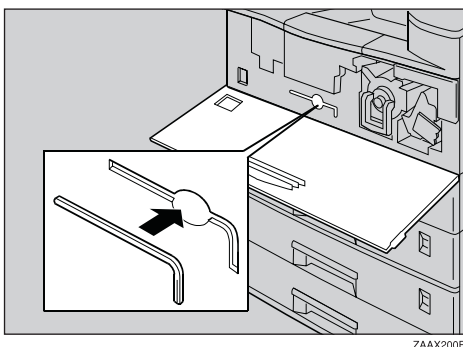

Where to Put Your Machine

Machine Environment

Your machine's location should be carefully chosen because environmental conditions greatly affect its performance.

Optimum environmental conditions

⚠ CAUTION:

- *Keep the equipment away from humidity and dust. Otherwise a fire or an electric shock might occur.*
- *Do not place the equipment on an unstable or tilted surface. If it topples over, it could cause injury.*

⚠ CAUTION:

- *Before moving the equipment, be sure to pull all four handles fully out. Not doing this may result in an injury, such as getting your fingers pinched. After moving the equipment, return the four handles to their original positions.*
- *When the optional paper tray unit is installed, do not push the upper part of the main unit horizontally. If the paper tray unit becomes detached from the main unit, this could cause an injury.*

⚠ CAUTION:

- *If you use the equipment in a confined space, make sure there is a continuous air turnover.*

- Temperature: 10 – 32°C (50 – 89.6°F), humidity 50% at 32°C, 89.6°F
- Humidity: 15 – 80%, temperature 27°C, 80.6°F at 80%
- A strong and level base.
- The machine must be level within 5mm, 0.2" both front to rear and left to right.
- To avoid possible build-up of ozone, be sure to locate this machine in a large well ventilated room that has an air turnover of more than 30 m³/hr/person.

Environments to avoid

- Locations exposed to direct sunlight or strong light (more than 1,500 lux).
- Locations directly exposed to cool air from an air conditioner or heated air from a heater. (Sudden temperature changes might cause condensation within the machine.)
- Places where the machine might be subjected to frequent strong vibration.
- Dusty areas.
- Areas with corrosive gases.

Power Connection

⚠ **WARNING:**

- **Only connect the machine to the power source described on the inside front cover of this manual. Connect the power cord directly into a wall outlet and do not use an extension cord.**
- **Do not damage, break or make any modifications to the power cord. Do not place heavy objects on it. Do not pull it hard nor bend it more than necessary. These actions could cause an electric shock or fire.**

⚠ **CAUTION:**

- *Unplug the power cord from the wall outlet before you move the equipment. While moving the equipment, you should take care that the power cord will not be damaged under the equipment.*

⚠ **CAUTION:**

- *When you disconnect the power plug from the wall outlet, always pull the plug (not the cable).*

- When the main switch is in the Stand-by positions, the optional anti-condensation heaters are on. In case of emergency, unplug the machine's power cord.
- When you unplug the power cord, the anti-condensation heaters turn off.
- Make sure the plug is firmly inserted in the outlet.
- Voltage must not fluctuate more than 10%.

Access to Machine

Place the machine near the power source, providing clearance as shown.

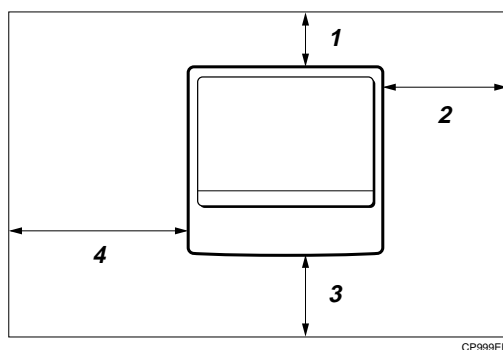

1. Rear: more than 1cm (0.4")

3. Front: more than 75cm (29.6")

2. Right: more than 1cm (0.4")

4. Left: more than 1cm (0.4")

Note

- For the required space when options are installed, please contact your service representative.

Maintaining Your Machine

If the exposure glass, platen covers or document feeder white sheet is dirty, you might not be able to make copies as you want. Clean them if you find them dirty.

❖ Cleaning the machine

Wipe the machine with a soft, damp cloth. Then wipe it with a dry cloth to remove the water.

⚠ Important

- ❑ Do not use chemical cleaner or organic solvent such as thinner or benzene. If they get into the machine or melt plastic parts, a failure might occur.
- ❑ Do not clean parts other than those specified in this manual. Such parts should be cleaned by your service representative.

5

Cleaning the Exposure Glass



Cleaning the Platen Cover

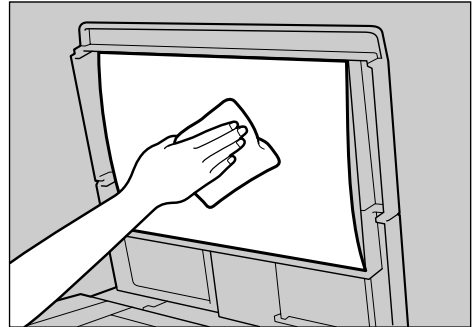

Cleaning the Document Feeder

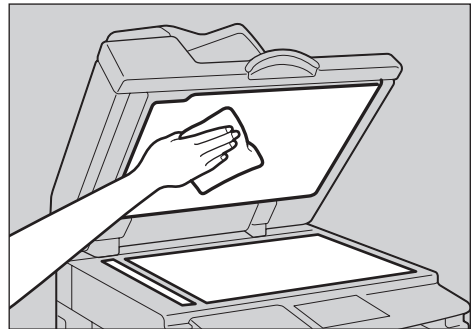

6. Specification

Mainframe

- ❖ **Configuration:**
Desktop
- ❖ **Photosensitivity type:**
OPC drum ($\Phi 30$)
- ❖ **Original scanning:**
One-dimensional solid scanning system through CCD
- ❖ **Copy process:**
Dry electrostatic transfer system
- ❖ **Development:**
Dry two-component magnetic brush development system
- ❖ **Fusing:**
Heating roll system
- ❖ **Resolution:**
600dpi
- ❖ **Exposure glass:**
Stationary original exposure type
- ❖ **Original reference position:**
Rear left corner
- ❖ **Warm-up time:**
Less than 45 seconds (20°C)
- ❖ **Originals:**
Sheet/book/objects
- ❖ **Maximum original size:**
A3☐, 11" × 17"☐
- ❖ **Copy paper size:**
 - Trays: A3☐ – A5☐, 11" × 17"☐ – $5\frac{1}{2}$ " × $8\frac{1}{2}$ "☐
 - Bypass: A3☐ – A5☐, 11" × 17"☐ – $5\frac{1}{2}$ " × $8\frac{1}{2}$ "☐
 - Bypass (non-standard size):
Vertical: 90 – 305mm, 3.6" – 12.0"
Horizontal: 148 – 432mm, 6.0" – 17.0"
 - Duplex: A3☐ – A5☐, 11" × 17"☐ – $8\frac{1}{2}$ " × 11"☐
 - LCT: A4☐, $8\frac{1}{2}$ " × 11"☐

❖ **Copy paper weight:**







- Paper tray: 64 – 105g/m² (20 – 28 lb)
- Bypass tray: 64 – 157g/m² (20 – 42 lb)
- Duplex unit: 64 – 105g/m² (20 – 28 lb)
- LCT: 64 – 105g/m² (20 – 28 lb)

❖ **Non-reproduction area:**





- Leading edge: 3 ± 2mm
- Trailing edge: 3 ± 3/-2mm
- Left edge: 2 ± 1.5mm
- Right edge: 2 ± 2.5mm/-1.5

❖ **First copy time:**





5 seconds or less

(A4 , 8¹/₂" × 11"  100%, feeding from 1st paper tray, A4  , 8¹/₂" × 11"   Text mode, Auto Image Density)

❖ **Copying speed: (Type 1)**

- 13 copies/minute (A3 , 11" × 17" )
- 15 copies/minute (B4JIS )
- 22 copies/minute (A4 , 8¹/₂" × 11" )

❖ **Copying speed: (Type 2)**

- 15 copies/minute (A3 , 11" × 17" )
- 17 copies/minute (B4JIS )
- 27 copies/minute (A4 , 8¹/₂" × 11" )

❖ **Reproduction ratio:**

Preset reproduction ratios:

--	Metric version	Inch version
Enlargement	400% ^{*1}	400% ^{*1}
	200%	200%
	141%	155%
	122%	129%
	115%	121%
Full Size	100%	100%
Reduction	93%	93%
	87%	85%
	82%	78%
	71%	73%
	65%	65%
	50%	50%
	25% ^{*1}	25% ^{*1}

Zoom: From 25% to 400 % in 1% steps.

^{*1} When you set the originals in the document feeder, you can change the reproduction ratio from 50 – 200 %.

❖ **Continuous copying count:**

1 – 99 copies

❖ **Copy paper capacity:**

- 1st and 2nd paper trays: 500 sheets (80g/m², 20 lb)

❖ **Power consumption:**

- Mainframe only

	Type 1	Type 2
Warm up	About 1.0kW	About 1.0kW
Stand-by	About 120Wh	About 120Wh
Copying	About 500Wh	About 500Wh
Maximum	Less than 1.44kW	Less than 1.44kW

- Full system

	Type 1 ^{*1}	Type 2
Warm up	About 1.0kW	About 1.0kW
Stand-by	About 130Wh	About 130Wh
Copying	About 500Wh	About 500Wh
Maximum	Less than 1.44kW	Less than 1.44kW

^{*1} Mainframe with the document feeder, bridge unit, paper tray unit, large capacity tray, finisher, duplex unit, 1 bin tray and 48MB copier memory unit.

❖ **Dimensions (W × D × H up to exposure glass):**

- 550 × 580 × 709mm, 21.7" × 22.9" × 28.0"

❖ **Noise Emission (ISO7779 Sound Power Level)**

Based on actual measurement

	Mainframe only	Complete System
Copying	64dB (A)	67.5dB (A)
Stand-by	40dB (A)	40dB (A)

❖ **Weight:**

- Type 1, 2: Approx. 55kg, 121.3 lb

 **Note**







- ❑ Specifications are subject to change without notice.

Document Feeder (Option)

❖ Mode:

ADF mode, SADF mode

❖ Original size:

- A3  – A5  
- 11" × 17"  – 5¹/₂" × 8¹/₂"  

❖ Original weight:

- 1-sided originals: 40 – 128g/m² (11 – 34 lb)
- 2-sided originals: 52 – 105g/m² (14 – 28 lb) (Duplex)

❖ Number of originals to be set:

50 sheets (80g/m², 20 lb)

❖ Maximum power consumption:

50W (power is supplied from the main frame.)

❖ Dimensions (W × D × H):

550 × 470 × 130mm, 21.7" × 18.6" × 5.2"

❖ Weight:

Approx. 10kg, 22.1 lb

 Note

- Specifications are subject to change without notice.

Paper Tray Unit (Option)

❖ **Copy paper weight:**

64 – 105g/m² (20 – 28 lb)

❖ **Available paper size:**

A3☐, B4JIS☐, A4☐☐, B5JIS☐☐, A5☐, 5 1/2" × 8 1/2"☐, 7 1/4" × 10 1/2"☐, 8" × 10"☐☐, 8 1/2" × 11"☐☐, 8" × 13"☐, 8 1/2" × 13"☐, 8 1/2" × 14"☐, 8 1/4" × 13"☐, 10" × 14"☐, 11" × 17"☐, 8K☐, 16K☐☐

❖ **Maximum power consumption:**

28W (power is supplied from the main frame.)

❖ **Paper capacity:**

500 sheets (80g/m², 20 lb) × 2 trays

❖ **Dimensions (W × D × H):**

550 × 520 × 271mm, 21.7" × 20.5" × 10.7"

❖ **Weight:**

Approx. 25kg, 55.2 lb

 **Note**

☐ Specifications are subject to change without notice.

Internal Tray 2 (1bin tray) (Option)

❖ **Number of bins:**

1

❖ **Available paper size:**

A3, B4JIS, A4, B5JIS, A5, 11" × 17", 8 1/2" × 14", 8 1/2" × 11", 5 1/2" × 8 1/2"

❖ **Paper capacity:**

125 sheets (80g/m², 20 lb)

 **Note**

The paper capacity might be less than 125 sheets when copy paper is considerably curled.

❖ **Copy paper weight:**

60 – 105g/m² (16 – 28 lb)

❖ **Dimensions (W × D × H):**

530 × 410 × 110mm, 20.9" × 16.2" × 4.4"

❖ **Weight:**

Approx. 1.1kg, 2.5 lb

 **Note**

Specifications are subject to change without notice.

Finisher (Option)

❖ Paper size:

A3, B4JIS, A4, B5JIS, A5, 5 1/2" × 8 1/2", 8" × 10", 8" × 13", 8 1/2" × 11", 8 1/2" × 13", 8 1/2" × 14", 8 1/4" × 13", 10" × 14", 11" × 17", 8K, 16K

❖ Paper weight:

52 – 157g/m², 14 – 42 lb

❖ Stack capacity:

- 1,000 sheets (A4, 8 1/2" × 11" or smaller) (80g/m², 20 lb)
- 500 sheets (B4JIS, 8 1/2" × 14" or larger) (80g/m², 20 lb)

❖ Staple capacity:

- 30 sheets (A4, 8 1/2" × 11" or smaller) (80g/m², 20 lb)
- 20 sheets (B4JIS, 8 1/2" × 14" or larger) (80g/m², 20 lb)

❖ Staple paper size:

A3, B4JIS, A4, B5JIS, 8" × 10", 8 1/2" × 11", 8" × 13", 8 1/2" × 13", 8 1/2" × 14", 8 1/4" × 13", 10" × 14", 11" × 17", 8K, 16K

❖ Staple paper weight:

64 – 80g/m², 17 – 20 lb

❖ Staple position:

1 position (upper left)

❖ Power consumption:

48W (power is supplied from the main frame.)

❖ Dimensions (W × D × H):

568 × 520 × 625mm, 22.4" × 20.5" × 24.6"

❖ Weight:

Approx. 21kg, 46.3 lb

Shift Sort Tray (Option)

❖ **Paper size:**

A3, B4JIS, A4, B5JIS, A5, B6, A6, 5 1/2" × 8 1/2", 7 1/4" × 10 1/2", 8" × 10", 8 1/2" × 11", 8" × 13", 8 1/2" × 13", 8 1/2" × 14", 8 1/4" × 13", 11" × 17", 8K, 16K

❖ **Paper weight:**

52 – 157g/m², 14 – 42 lb

❖ **Paper capacity:**

250 sheets (A4, 8 1/2" × 11" or smaller) (80g/m², 20 lb)
 125 sheets (B4JIS, 8 1/2" × 14" or larger) (80g/m², 20 lb)

❖ **Power consumption:**

3.6 W (power is supplied from the main frame.)

❖ **Dimensions (W × D × H)**



430 × 372 × 148 mm, 17" × 15" × 6"

❖ **Weight:**

Approx. 1.6kg, 3.5 lb

Large Capacity Tray (LCT) (Option)

❖ **Paper size:**

- Metric version: A4 
- Inch version: 8¹/₂" × 11" 

❖ **Paper weight:**

64 – 105g/m², 20 – 28 lb

❖ **Paper capacity:**

2,000 sheets (80g/m², 20 lb)

❖ **Power consumption**

Approx. 30W (power is supplied from the main frame.)

❖ **Dimensions (W × D × H):**

550 × 520 × 271mm, 21.7" × 20.5" × 10.7"

❖ **Weight:**

Approx. 25kg, 55.2 lb

Duplex Unit (Option)

❖ **Paper size:**

A3, B4JIS, A4, B5JIS, A5, 5 1/2" × 8 1/2", 7 1/4" × 10 1/2", 8" × 10", 8 1/2" × 11", 8" × 13", 8 1/2" × 13", 8 1/2" × 14", 8 1/4" × 13", 11" × 17", 8K, 16K

❖ **Paper weight:**

64 – 105g/m², 20 – 28 lb

❖ **Power consumption (Max):**

35W (power is supplied from the main frame.)

❖ **Dimensions (W × D × H):**

90 × 520 × 400mm, 3.6" × 20.5" × 15.8"

❖ **Weight:**

Approx. 6kg, 13.3 lb

Bypass Tray (Option)

❖ **Available paper size:**

- Standard size (metric version): A3, A4, A5, 8" × 13"
- Standard size (inch version): 11" × 17", 8¹/₂" × 14", 8¹/₂" × 13", 8¹/₂" × 11", 5¹/₂" × 8¹/₂"
- Non-standard size: Vertical (90 – 305mm, 3.6" – 12.0"), Horizontal (148 – 432mm, 6.0" – 17.0")

❖ **Copy paper weight:**

60 – 157g/m², 16 – 42 lb

❖ **Dimensions (W × D × H):**

296 × 495 × 163mm, 11.7" × 19.5" × 6.5"

❖ **Paper capacity:**

- 52 – 90g/m², 16 – 20 lb: 100 sheets

❖ **Weight:**

Approx. 2.5kg, 5.6 lb

48MB Copier Memory Unit (Option)

- ❖ **Memory capacity:**
48MB
- ❖ **Additional functions:**
 - Enhanced print quality
 - Increased memory capacity
- ❖ **Number of originals that can be stored: about 100 pages**
(reference value based on ITU-T No.4 chart)

INDEX

1000-sheet finisher, 7, 35, 140
1 bin tray, 7, 139
48MB copier memory unit, 7, 145

A

Access to Machine, 131
Adding Staples, 107
Adjusting Copy Image Density, 30
Auto Image Density, 30
Auto Off, 26
Auto Paper Select, 32
Auto Reduce/Enlarge, 33
Auto Reset, 26
Auto Start, 48

B

Basic Functions, 30
Both Covers, 69
Bridge unit, 7
Bypass tray, 6, 7, 41, 144

C

Changing the Paper Size, 103
Changing the Toner Bottle, 91
Clearing Misfeeds, 98
Combination Chart, 80
Combine, 58
Copying from the Bypass Tray, 41
copy initial display, 11
Copy Paper, 19
Cover, 68

D

Deleting a Program, 46
Directional Magnification (%), 55
Directional Size Magnification (inch), 53
Document feeder (ADF), 5, 7, 27, 132, 137
Do's and Don'ts, 129
Duplex, 64
Duplex unit, 7, 143

E

Energy Saver, 47
Enlarging, 50

Erase Border, 56
Erase Center, 56
Exposure glass, 5, 16, 18, 27, 132

F

Fax key, 15
Front Cover, 68
Front cover, 6

I

Image Repeat, 72
Interchange unit, 7
Internal tray, 5
Internal tray 2, 7, 139
Interrupt, 47

J

Jammed Staples, 109

L

Large Capacity Tray (LCT), 7, 90, 142
Loading Paper, 89
Lower right cover, 6

M

Machine Environment, 130
Mainframe, 133
Main Power indicator, 6
Main power switch, 5, 13
Maintaining, 132
Manual Image Density, 30
Message, 83

O

OHP Slip Sheet, 70
On indicator, 6
Operation panel, 6, 8
Operation switch, 6, 13
Options, 7
Originals, 16, 27
Original Tone, 49
Original type, 31

P

Panel display, 11

Paper tray, 6
Paper tray cover, 6
Paper tray unit, 6, 7, 138
Photo Conductor Unit, 24
Platen cover, 5, 7, 132
Positive/Negative, 71
Power Connection, 131
Preset Reduce/Enlarge, 50
Program, 45

R

Recalling a Program, 46
Reducing, 50
Remarks, 129
Replacing the Photo Conductor Unit, 93
Rotate Sort, 36

S

Safety Information, i
Selecting Copy Paper, 31
Selecting Original Type Setting, 31
Series Copies, 62
Shift Sort, 36
Shift Stack, 37
Sort, 35
Specification, 133
Stack, 37
Staple, 38
Storing Your Settings, 45

T

Toner, 23

U

User Codes, 48
User Tools, 111

V

Ventilation hole, 5

Z

Zoom, 52

