

Miele

Operating instructions

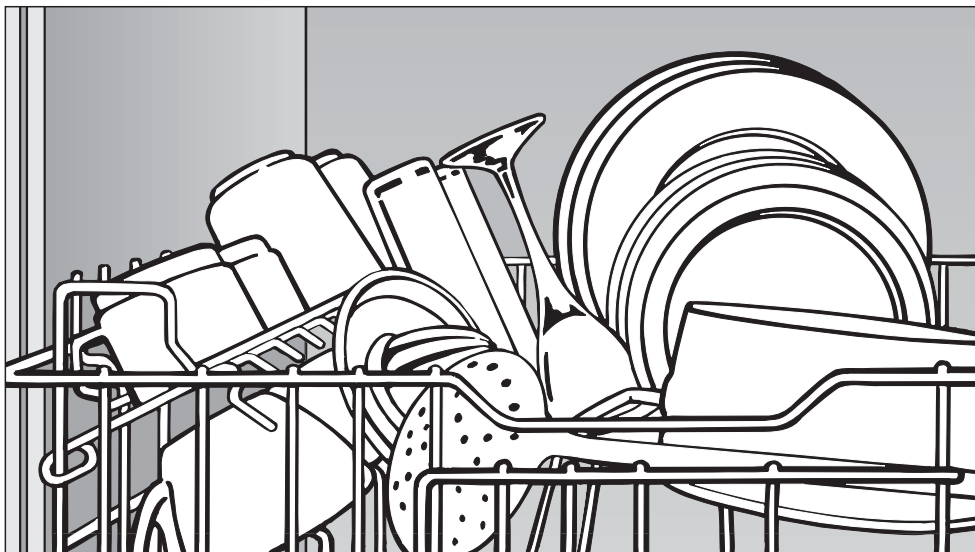

for dishwashers

It is **essential** to read the operating and installation instructions before installing or using the machine, to avoid the risk of accident or damage to the machine.



M.-Nr. 05 184 480

Contents

Guide to the appliance	4
View of the machine	4
Control panel (fascia)	5
Warning and safety instructions	6
Caring for the environment	10
Disposal of the packing material	10
Disposal of your old appliance	10
Energy saving washing	10
Before using for the first time	11
Before using the machine for the first time you require	11
To open the door	12
To close the door	12
Child safety lock	12
Water softener	13
Programming and setting the water hardness level	14
Programming the machine to the water hardness level	14
Setting the water hardness level selector in the wash cabinet	15
Checking the programmed water hardness level	16
Filling the salt reservoir	17
Salt indicator	18
Rinse aid	19
Adding rinse aid	19
Rinse aid indicator	20
Setting the rinse aid dosage	21
Loading the dishwasher	22
Loading examples	23
Upper basket	23
Flap up rack	23
Positioning rail	23
Adjusting the upper basket	24
Lower basket	25
Bottle holder	26
Cutlery	26
Items not suitable for dishwashers	29

Operating the dishwasher	30
Adding detergent	30
Programme selection	33
Switching on	34
Starting a programme	34
Programme sequence indicator lights	34
At the end of a programme	35
Switching off	35
Interrupting a programme	36
Changing a programme	36
Drying fan running time	37
Unloading the dishwasher	38
Cleaning and care	39
Cleaning the filters in the wash cabinet	39
Cleaning the spray arms	41
Cleaning the wash cabinet	42
Cleaning the door and the door seal	42
Cleaning the control panel (fascia)	42
Cleaning the door panel	42
Problem solving guide	43
Solving problems	50
Cleaning the water inlet filter	50
Checking the water level	51
Increasing the water intake time	52
Cleaning the drain pump and non-return valve	53
After sales service	55
Special accessories	56
Comparison tests	57
Transport	59
Programme chart	60
Technical data	62

Guide to the appliance

View of the machine

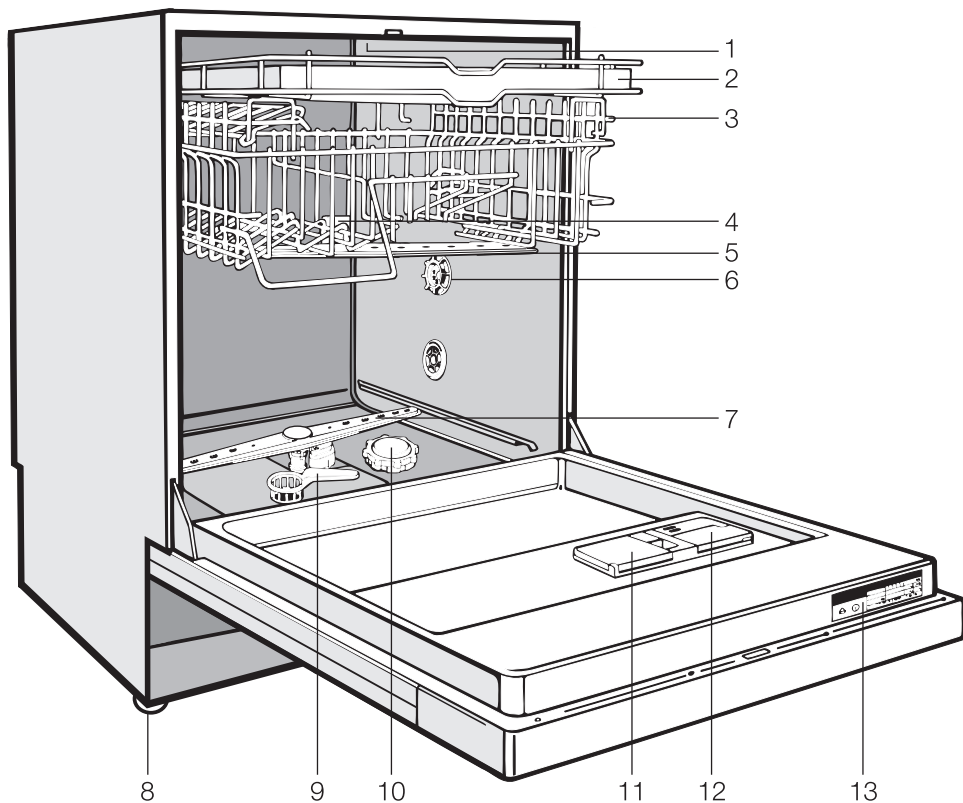

- | | |
|--|--|
| 1 Upper spray arm (not visible) | 8 Four height adjustable screw feet |
| 2 Cutlery tray
(depending on model) | 9 Filter combination |
| 3 Upper basket | 10 Salt reservoir |
| 4 Water feed for middle
spray arm | 11 Dual compartment detergent
dispenser |
| 5 Middle spray arm | 12 Rinse aid reservoir
(with dosage selector) |
| 6 Water hardness selector | 13 Data plate |
| 7 Lower spray arm | |

Control panel (fascia)

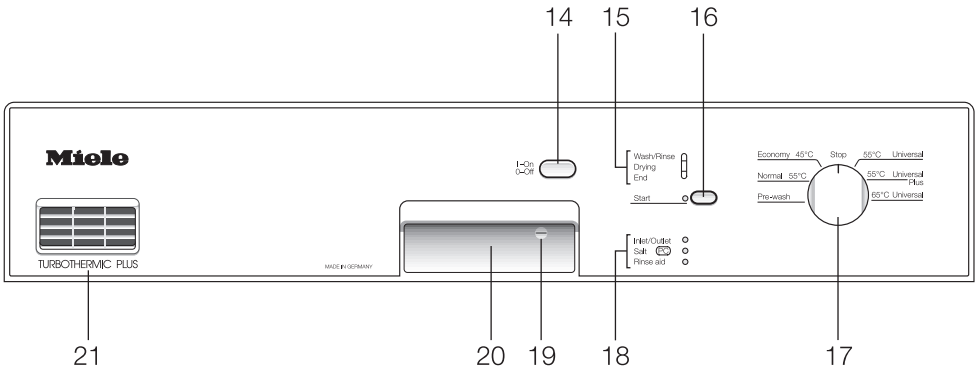

- 14 "On/Off" button
- 15 Programme sequence display
- 16 Start button
- 17 Programme selector
- 18 Check/Refill indicators
- 19 Child safety lock
- 20 Door release
- 21 Ventilation outlet for drying fan

Warning and safety instructions

This appliance conforms to current safety requirements. Inappropriate use can however lead to personal injury and damage to property. Read the operating instructions carefully before starting to use this machine. This way you will avoid the risk of accidents, and damage to the machine. Keep these instructions in a safe place for reference, and pass them on to any future user.

Appropriate usage

This dishwasher is intended exclusively for cleaning domestic crockery and cutlery in a domestic household. Do not use for purposes other than those for which it was designed. Any other applications may be dangerous.

The manufacturer cannot be held responsible for any damage caused by improper use or for uses other than those for which the appliance is intended.

Delivery

A damaged appliance is dangerous. It is therefore essential to check packaging immediately and examine the dishwasher for transport damage. Under no circumstances should you use a damaged machine.

Please ensure that the packaging material is offered for recycling.

Installation

The dishwasher must be installed and connected in compliance with the installation instructions.

To ensure stability this dishwasher must be built into a tall housing unit.

Do not connect the dishwasher to the mains supply until it has been installed.

Check that the voltage, frequency and fuse rating shown on the data plate match the household mains supply.

The electrical safety of this appliance can only be guaranteed when continuity is complete between the appliance and an effective earthing system. It is imperative that this basic safety requirement is tested and where there is any doubt the electrical system in the house is checked out by a qualified electrician.

The manufacturer cannot be held responsible for damage caused by the lack or inadequacy of an effective earthing system (electric shock, for example).

A damaged appliance is dangerous. Switch off at the mains and call your Miele supplier or the Miele Service Department.

Warning and safety instructions

■ With the “Waterproof system” the plastic housing of the water inlet connection contains an electrical component. The housing must therefore not be dipped in water.

■ Never cut the water inlet hose, even if it is too long. There are live wires in this hose.

■ For safety reasons do not operate this appliance on an extension cable. (Danger of overheating).

Daily use

■ Do not use solvents in the dishwasher. Danger of explosion.

■ Water in the dishwasher must not be used as drinking water.

■ Avoid inhalation of powder detergents. Dishwasher detergents contain irritant or corrosive ingredients. They can cause burning in the mouth and throat if swallowed, or inhibit breathing. Consult a doctor immediately if detergent has been swallowed or inhaled.

■ Do not sit or lean on the opened door. This could cause the dishwasher to tip and be damaged and you could get injured.

■ In an appliance with a cutlery basket (depending on model) cutlery is cleaned and dried more efficiently if placed in the basket with the handles downwards. However, to avoid the risk of injury place cutlery with sharp points with the handles upwards.

■ Only use detergents formulated for domestic dishwashers. Do not use washing-up liquid.

■ Only use rinse aid formulated for domestic dishwashers.

■ Only use special coarse grained dishwasher salt for reactivation, as other salts may contain insoluble additives which can impair the functioning of the softener.

■ Plastic items which cannot withstand being washed in hot water, such as disposable plastic containers, or plastic cutlery and crockery should not be cleaned in the dishwasher. The high temperatures in the dishwasher may cause them to melt or lose shape.

Take care on dishwashers with a visible heater element

■ Do not touch the heating element during or directly after the end of a programme, you could burn yourself.

■ Some plastic items could melt or catch fire if they were to come into contact with the heating element. Therefore always place plastic items or any other items which may not be completely heat resistant in the upper basket and ensure they cannot drop down onto the heater element. Any items which are too small to be lodged securely in the upper basket should not be cleaned in the dishwasher.

Warning and safety instructions

Safety with children

Do not let small children play with the dishwasher and its controls or operate it. There is a danger that children playing might shut themselves in the dishwasher.

Keep children away from detergents. Dishwasher detergents contain irritant or corrosive ingredients. They can cause burning in the mouth and throat if swallowed, or inhibit breathing. Consult a doctor immediately if your child has swallowed or inhaled detergent.

To avoid the danger of children coming into contact with the dishwasher detergent: Only add detergent just before starting the programme and close the door, activating the child safety lock (depending on model).

Keep children away from the dishwasher when the door is open. There could be detergent residues in the appliance.

To ensure children do not come into contact with detergent: For models with the "Delay start" option make sure the dispenser is dry before adding detergent. Wipe dry if necessary. Detergent will clog if poured into a damp dispenser and may not be thoroughly dispersed. If the door is open at the end of a programme, children may come into contact with this residue.

To avoid machine and material damage

Do not fill the rinse aid reservoir with powder or liquid detergent. This will cause serious damage to the reservoir.

Inadvertently filling the salt reservoir with powder or liquid dishwasher detergent always leads to serious damage to the water softener.

Do not use commercial or industrial detergents as these may damage material and there is a risk of severe chemical reaction.

The Miele Waterproof System offers protection from water damage, provided the following conditions are met:

- The dishwasher is correctly installed and plumbed in.
- The dishwasher is properly maintained and parts are replaced where it can be seen that this is necessary.
- The stopcock has been turned off when the machine is not used for a longer period of time (e.g. during holidays).

Warning and safety instructions

In countries where there are areas which may be subject to infestation by cockroaches or other vermin, pay particular attention to keeping the appliance and its surroundings in a clean condition at all times. Any damage which may be caused by cockroaches or other vermin will not be covered by the appliance guarantee.

Repairs and maintenance

Repairs may only be carried out by suitably qualified and competent engineers in accordance with local and national safety regulations. Repairs by unqualified persons could be dangerous.

Always disconnect the appliance from the electrical supply for maintenance work (switch off at wall socket and remove the plug, or remove the screw out fuse in countries where this is applicable).

Disposal of your old machine

When disposing of an old dishwasher first make it unusable. Disconnect, cut off the cable and the plug from the cable.

Make the door lock inoperative (2 cross-slotted screws), so that children cannot accidentally shut themselves in. Make appropriate arrangements for the safe disposal of the appliance.

The manufacturer cannot be held responsible for any damage caused by non-observance of the warning and safety instructions.

Caring for the environment

Disposal of the packing material

The transport and protective packing has been selected from materials which are environmentally friendly for disposal and can normally be recycled. Rather than just throwing these materials away, please ensure they are offered for recycling.

Disposal of your old appliance

Old appliances contain materials which can be recycled. Please contact your local authorities or scrap merchant about potential recycling schemes, before disposing of the appliance. Ensure that the appliance presents no danger to children while being stored for disposal. See the appropriate section in the Warning and Safety instructions.

Energy saving washing

This dishwasher is exceptionally economical in its use of water and electricity. You can make the most of your appliance by following these tips:

- If your household water system is suitable, this dishwasher can be connected to a hot water supply, for further economies.
Although all stages of the wash then take place with hot water, savings are made in:
 - the use of primary energy
 - costs
 - programme running time.If, however, your water is heated by electricity we would still recommend connection to cold water.
- For most economical dishwashing make full use of the baskets without overloading the dishwasher.
- Choose the programme to suit the type of crockery being washed and the degree of soiling.
- Select the Economy 45°C programme for energy-saving dishwashing.
- Use the correct amounts of detergent.
- Use only 2/3 of the given dosage if baskets are only half full.

Before using the machine for the first time you require:

- approx. 2 litres of water,
- approx. 2 kg dishwasher reactivation salt,
- domestic dishwasher detergent,
- rinse aid formulated for domestic dishwashers.

Every dishwasher is tested at the factory.

There will be residual water in the machine from this test. It is not an indication that the machine has been previously used.

Before using for the first time

To open the door

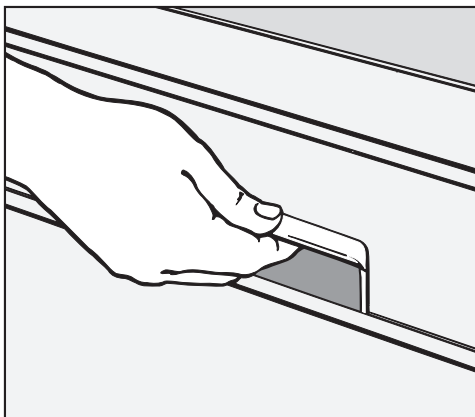

- Press the release catch inside the door grip and pull forward.

If the door is opened during operation all functions are automatically interrupted.

To close the door

- Push the baskets right in. Lift the door and push until it clicks into position.

Child safety lock

The yellow key for the child safety lock is on one of the spikes at the front of the upper basket. Remove the key before switching on the dishwasher and keep it in a safe place away from the dishwasher.

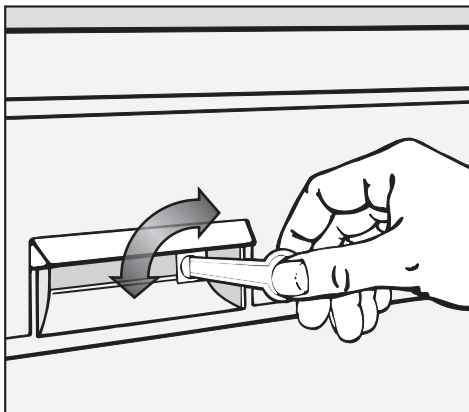

If you wish to prevent children opening the dishwasher door during operation use the key provided to turn the lock to the required setting.



Horizontal setting:
The door is locked.



Vertical setting:
The door can be opened.

Before using for the first time

Water softener

In order to achieve good cleaning results, the dishwasher needs to operate with soft water. Hard water results in the build-up of calcium deposits on crockery and in the dishwasher. Hence if mains water hardness is above 4 °d (0.7 mmol/l), the water should be softened. This takes place automatically in the integrated water softener.

- The water softener must be filled with dishwasher salt for reactivation.
- The water softener must be set to correspond to the water hardness in your area.
- Your local water authority will advise you on the highest level of water hardness in your area.

If the hardness of your local supply is constantly lower than 4 °d (= 0.7 mmol/l), you do not need to add dishwasher salt. The water softener must, however, still be programmed to correspond to the water hardness level in your area.

Where the water hardness fluctuates e.g. between 8 - 17 °d (1.4 - 3.1 mmol/l), always set the machine to the higher value (17 °d in this example).

In the case of a fault, it will help the service technician if you know the hardness of your local water supply.

- Enter the water hardness below:

_____ °d

Before using for the first time

Programming and setting the water hardness level

The water hardness level of your water supply must be programmed into the machine using the programme selector. The water hardness level selector in the wash cabinet is then also set to the water hardness level in your area.

Programming the machine to the water hardness level

- Switch the appliance off with “On/Off” button.
- Turn the programme selector to “Stop”.
- Press the “Start” button in and whilst doing so at the same time switch the dishwasher on using the “On/Off” button. Release the “Start” button again within two seconds.

The “Salt” indicator light will start flashing.

Note:

If a different indicator light is on or flashing, the process must be repeated.

Exception:

The “Rinse aid” indicator light will come on if you have not yet added rinse aid or if rinse aid needs replenishing.

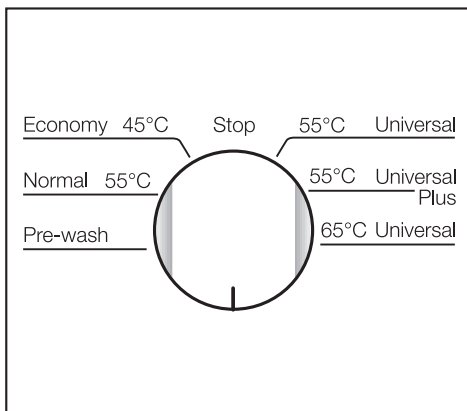

- Turn the programme selector to the position that corresponds to your water hardness level (see chart below).

°d	mmol/l	Programme selector setting
1 - 4	0.2 - 0.7	Universal 55° (1 o'clock)
5 - 7	0.9 - 1.3	Universal Plus 55° (2 o'clock)
8 - 10	1.4 - 1.8	Universal 65° (3 o'clock)
11 - 14	2.0 - 2.5	4 o'clock position
15 - 17	2.7 - 3.1	5 o'clock position
18 - 21	3.2 - 3.8	6 o'clock position
22 - 35	4.0 - 6.3	7 o'clock position
36 - 70	6.5 -12.6	8 o'clock position

The dishwasher is set at the factory for a hardness level of 22 - 35 °d (4.0 - 6.3 mmol/l).

Example:

For a water hardness level of 20 °d. Turn the programme selector to the 6 o'clock position.

Before using for the first time

- Press the “Start” button.

The “Start” indicator light will come on.

- Turn the programme selector to the “Stop” position.
- Switch the appliance off by pressing the “On/Off” button.

The water hardness level is now stored in memory.

Setting the water hardness level selector in the wash cabinet

The water hardness level selector in the wash cabinet must be set according to the table below.

Setting the selector to the correct setting will help minimise the effects of the wash process on glass surfaces. Too high a setting will lead to poor cleaning results and an increase in water spots left on crockery and cutlery.

- Use a screwdriver to take the cover off the water hardness level selector in the wash cabinet.

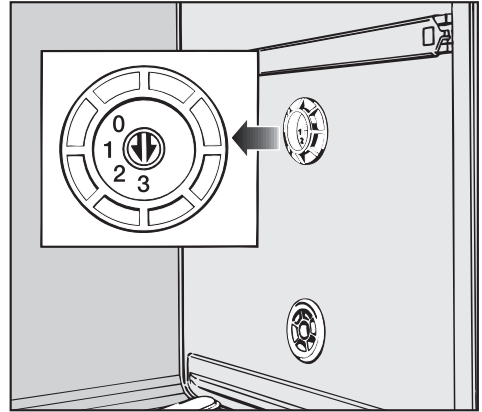

- Use a coin or screwdriver to adjust the water hardness level selector in the wash cabinet. There is a click as each setting is reached.

°d	mmol/l	°f	Selector setting (level)
1- 7	0.2 - 1.3	2 - 13	3
8-10	1.4 - 1.8	14 - 18	2
11-14	2.0 - 2.5	20 - 25	1
15-70	2.7 - 12.6	27 - 126	0

The water hardness selector is set at the factory to setting “1”.

Example:

For a water hardness level of 6 °d. Turn the water hardness level selector to setting 3 (1 - 7 °d).

- Replace the cover on the water hardness level selector.

Before using for the first time

Checking the programmed water hardness level

- Switch the appliance off by pressing the “On/Off” button.
- Turn the programme selector to the “Stop” position.
- Press the “Start” button in and whilst doing so at the same time switch the dishwasher on using the “On/Off” button. Release the “Start” button again within two seconds.

The “Salt” indicator light will start flashing.

Note:

If a different indicator light is on or flashing, the process must be repeated.

Exception:

The “Rinse aid” indicator light will come on if you have not yet added rinse aid or if rinse aid needs replenishing.

- Click the programme selector from the “Universal 55°” (1 o'clock) as far as the 8 o'clock position.

When the programme selector is at the position which corresponds to the water hardness setting already programmed, the “Start” indicator light will come on (see chart “Programming and setting the water hardness level”).

- Turn the programme selector to the “Stop” position.
- Switch the appliance off with the “On/Off” button.

Before using for the first time

Filling the salt reservoir

Important. Before filling the salt reservoir with dishwasher salt for the first time, you must fill it with approx. 2 litres of water to enable the salt to dissolve. Once the dishwasher has been used, there is always sufficient water in the reservoir.

Inadvertently filling the salt reservoir with powder or liquid dishwasher detergent always causes serious damage to the water softener. Make sure that you have picked up the right packet of dishwasher salt before filling the salt reservoir.

Please only use special coarse grained dishwasher salt for reactivation, as other salts may contain insoluble additives which can impair the functioning of the softener.

- Remove the lower basket and unscrew the salt reservoir cap.
- Fill the reservoir with approx. 2 litres of water (first use).

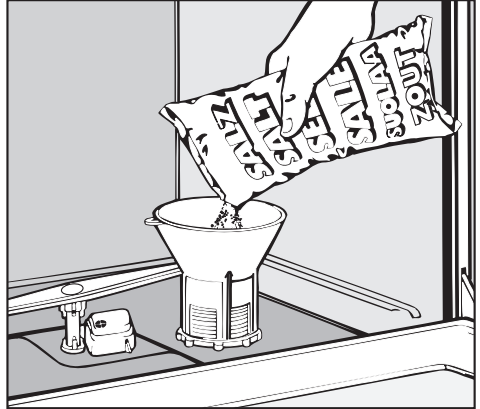

- Place the funnel provided over the salt reservoir and carefully fill with salt. The salt reservoir holds approx. 2 kg of salt.

As the salt reservoir is filled, displaced water will overflow.

- Clean any excess salt from around the reservoir opening and then screw the cap on again firmly.
- Run the Pre-wash programme immediately to remove any traces of salt water from the cabinet.

Before using for the first time

Salt indicator

The salt indicator light comes on to notify you that the reservoir is empty.

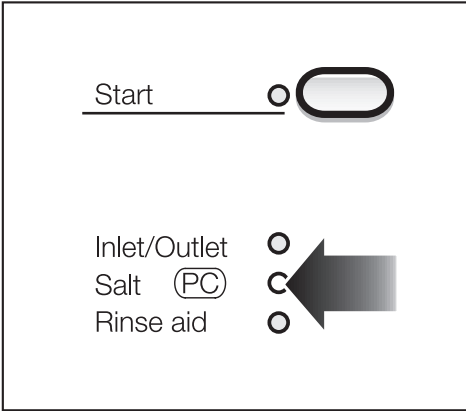

- The reservoir should then be refilled with dishwasher salt for reactivation. (See: Filling the salt reservoir)

After the reservoir has been filled, the water softener is automatically reactivated the next time the dishwasher is run. The salt indicator light may still be illuminated during this process. It will go out once the salt concentration has reached the correct level.

Note

The salt indicator light will also come on if the water used is very soft (below 4 °d / 0.7 mmol). In this case the reservoir should not be filled with salt. The indicator light will remain lit and should be ignored.

(See “After sales service” for definition of “PC”).

Before using for the first time

Rinse aid

Rinse aid is necessary to ensure water does not cling and leave marks on crockery during the drying phase.

Rinse aid is poured into the storage reservoir and the amount set is dispensed automatically.

Make sure you have added rinse aid before using the dishwasher for the first time.

Inadvertently filling the rinse aid reservoir with powder or liquid dishwasher detergent always causes serious damage to the reservoir. Only pour rinse aid formulated for domestic dishwashers into the reservoir.

Alternatively it is possible to use

- Household vinegar with a max. 5% acid content

Do not use vinegar with a higher acid content (e.g. vinegar essence 25% acid). This must not be used as its use would damage the dishwasher.

or

- Liquid citric acid up to 50% acid content. The resulting rinsing and drying quality will not, however, be as good as when rinse aid is used.

Adding rinse aid

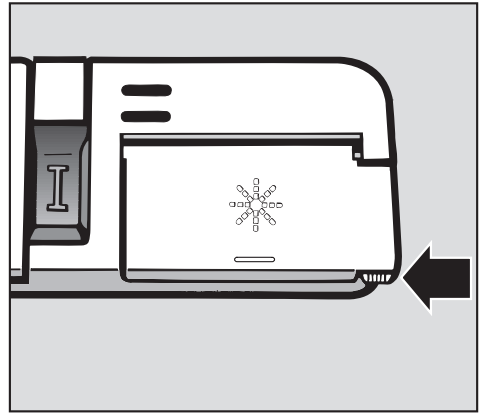

- Press the button in the direction of the arrow until the flap springs open.

Before using for the first time

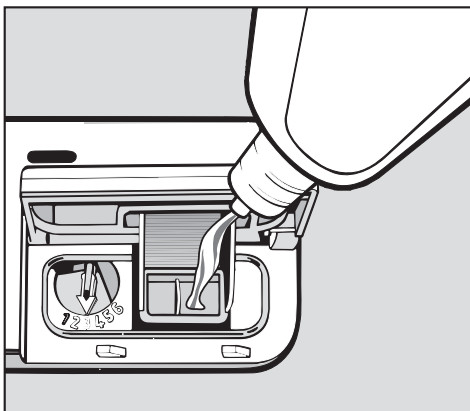

- Add rinse aid only until it is visible on the surface of the filter in the opening.

The rinse aid reservoir holds approx. 130 ml.

- Close the flap firmly so that it clicks into place. Otherwise water would enter the rinse aid reservoir during a programme.
- Wipe up any spilled rinse aid. This prevents over-foaming occurring during the next programme.

Rinse aid indicator

The Rinse aid indicator light on the fascia comes on when the rinse aid reservoir needs to be replenished.

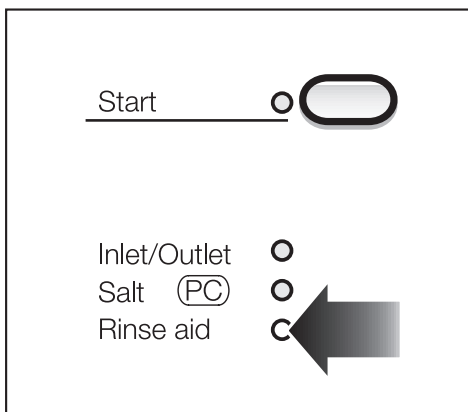

When the light comes on the reservoir still contains sufficient rinse aid for 2 - 3 programmes.

- Add rinse aid in plenty of time.

Setting the rinse aid dosage

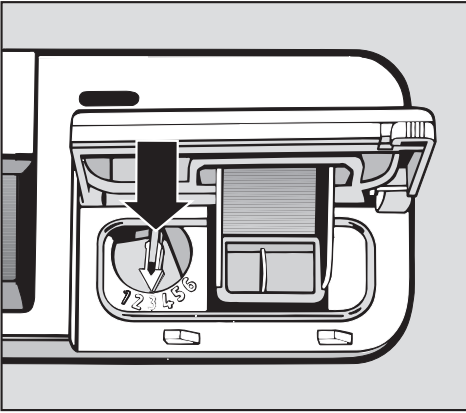

The dosage selector has settings from 1-6. It is set to 3 at the factory (see arrow). Approx. 3 ml of rinse aid are then used per programme. This is a recommended setting.

If spots appear on crockery and glassware:

- Use a higher setting.

If clouding or smearing appears on crockery and glassware:

- Use a lower setting.

Loading the dishwasher

Note

- Remove coarse food residues from crockery.

There is no need to rinse items under running water.

Do not wash items soiled with ash, sand, wax, lubricating grease or paint in the dishwasher. Ash does not dissolve and is distributed in the wash cabinet. Wax, sand, lubricating grease and paint cause damage to the dishwasher.

Crockery can be loaded anywhere in the baskets, but the following notes should be observed:

- Do not place crockery and cutlery inside other pieces where they may be concealed.
- Load the crockery so that water can access all surfaces. This ensures that it is properly cleaned.
- Make sure that all items are securely positioned.
- Hollow items such as cups, glasses, pans, etc. must be inverted in the basket.
- Tall, narrow, hollow items, e.g. champagne glasses, should be placed in the centre of the basket to ensure better water coverage.

- Deep-based items should be placed at an angle so that water can run off them freely.
- The spray arms must not be blocked by items which are too tall or hang through the baskets. If in doubt, test for free movement by manually rotating the spray arms.
- Make sure that small items do not fall through the holders in the baskets. Small items, e.g. lids, should therefore be placed in the cutlery tray or cutlery basket.

Some foodstuffs may contain natural dyes, e.g. carrots, tomatoes or ketchup. Plastic items in the dishwasher may discolour if large quantities of these foodstuffs find their way into the appliance on the crockery. The stability of plastic items is not affected by this discolouration.

When the dishwasher is being loaded food and drink residue may drip onto the sides of the dishwasher door. These surfaces do not belong to the wash cabinet and are not accessed by water from the spray arms. Food residue should therefore be wiped away before the dishwasher door is closed.

Loading the dishwasher

Loading examples

Upper basket

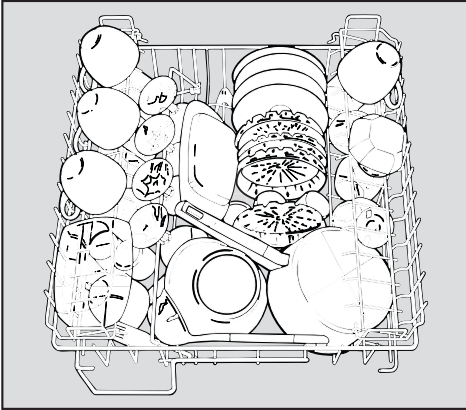

For small, lightweight, delicate items such as cups, saucers, glasses, dessert bowls, etc. Flat saucepans or casserole dishes can also be placed in the upper basket.

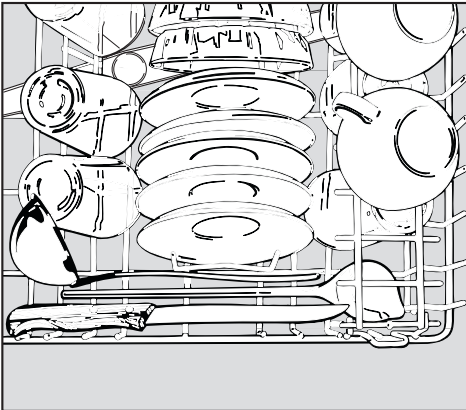

Long items such as soup ladles, mixing spoons and long knives should be placed lying down across the front of the upper basket.

Flap up rack

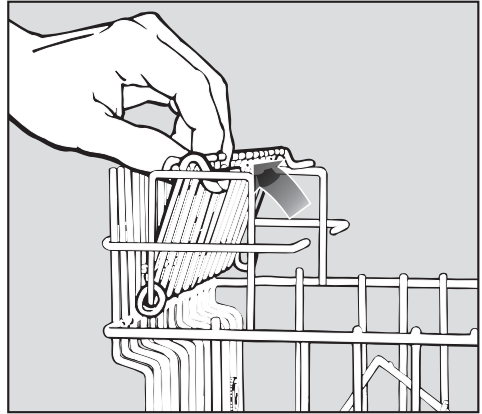

To make room for tall items raise the rack upwards.

Positioning rail (depending on model)

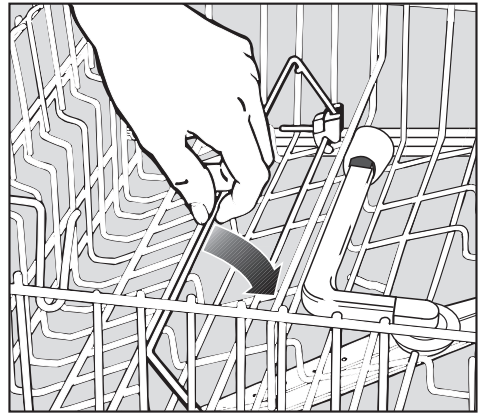

The positioning rail can be flipped over to the middle of the basket for easy sorting and removing of crockery.

Loading the dishwasher

Adjusting the upper basket

In order to gain more space for taller pieces of crockery in the bottom or upper basket, the upper basket can be adjusted on three levels with 2 cm between each level.

The upper basket can also be set at an angle with one side high, and the other side low. Ensure however, that the basket can be inserted smoothly into the cabinet.

- Pull out the upper basket.

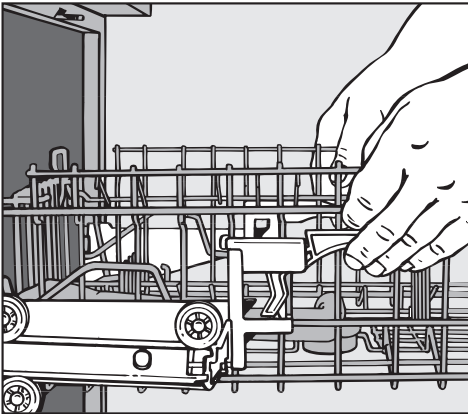

- Pull upwards on the levers at either side of the upper basket.
- Adjust the basket to the desired height.
- Then push the levers securely back down into position.

Depending on the setting of the upper basket, the following plate dimensions can be accommodated.

Dishwashers with cutlery tray

Upper basket level	Plate Ø in cm	
	Upper basket	Lower basket
Top	20.5	30
Middle	22.5	28
Bottom	24.5	26

Dishwashers with cutlery basket

Upper basket level	Plate Ø in cm	
	Upper basket	Lower basket
Top	26	30
Middle	28	28
Bottom	29.5	26

Loading the dishwasher

Lower basket

For larger and heavier items such as plates, serving platters, saucepans, bowls, etc.

Small items such as saucers can also be placed in the lower basket.

Do not place thin, delicate glassware in the lower basket unless a special basket with glassware insert is installed.

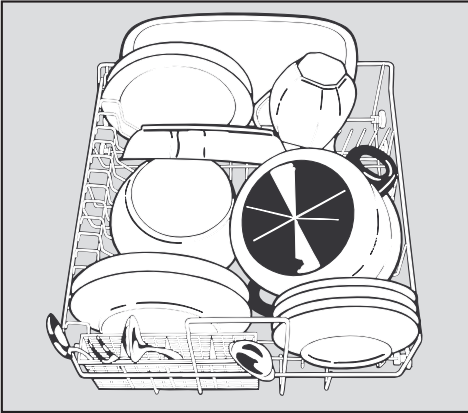

Height limitation

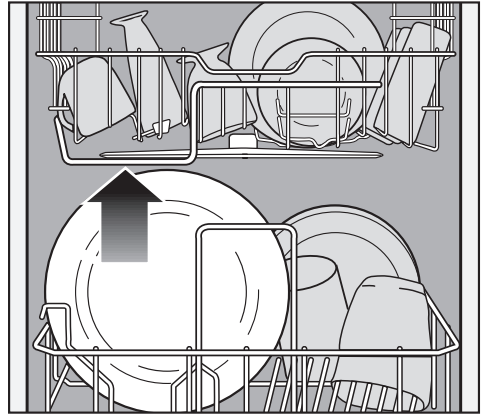

The stay at the front of the upper basket determines the max. height permissible for items placed in the lower basket to ensure they do not impede the movement of the middle spray arm.

Dishwashers with a cutlery tray

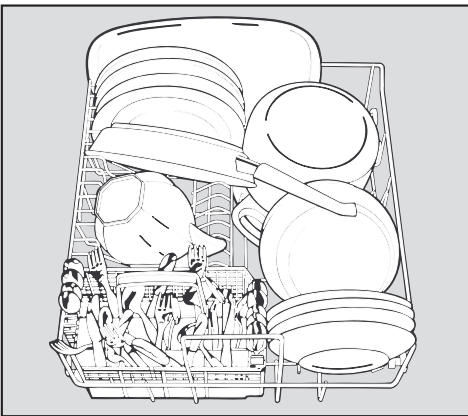

Dishwashers with a cutlery basket

Loading the dishwasher

Bottle holder

(depending on model)

The bottle holder e.g. for milk and baby bottles, can be inserted into the bottom basket in more than one place. Position in any area marked white in the illustration. Do not position in areas marked "X", as water cannot properly access bottles in these areas, hence cleaning results are impaired.

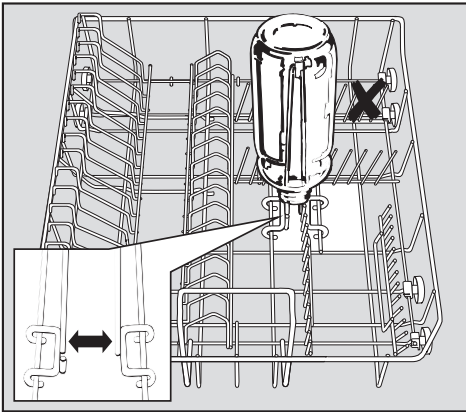

Cutlery

Dishwashers with a cutlery basket

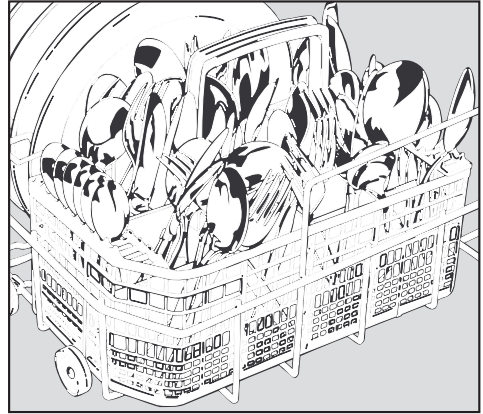

- Unsorted cutlery should be placed in the cutlery basket with the handles facing downwards to ensure optimum spray water access.

However, to avoid the risk of injury cutlery with sharp points should be placed with the handles upwards.

Place small spoons in the individual slots to either side of the cutlery basket.

Spoon inserts for the cutlery basket

Use the inserts supplied when washing heavily soiled spoons, e.g. tablespoons and serving spoons.

The inserts separate the spoons to allow a space between them so that they can be more easily accessed by water.

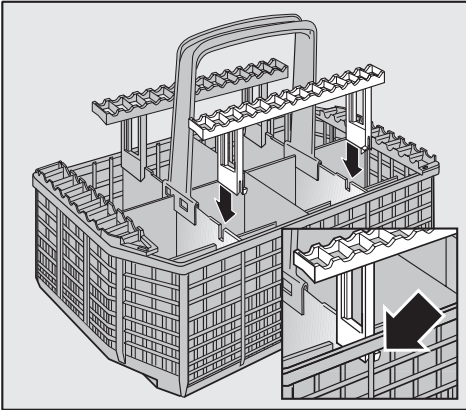

- If required, place an insert onto the front and rear of the cutlery basket.

To remove the inserts:

- Press the engaged hooks inwards (use a spoon handle if necessary) and remove the insert by pulling it upwards.

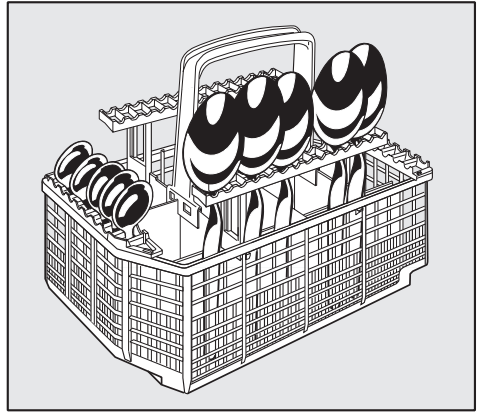

- Insert the spoons with the handles facing downwards, using only every other slot.

Loading the dishwasher

Dishwashers with a cutlery tray (SC)

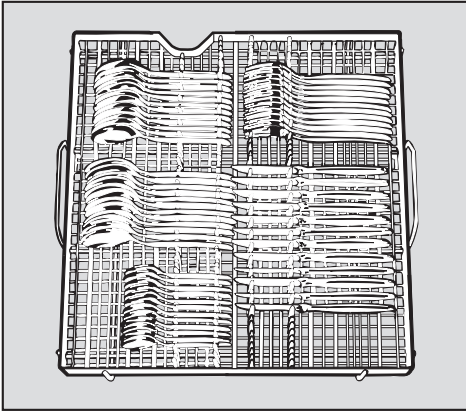

For best results cutlery should be grouped in zones, one for knives, one for forks, one for spoons, etc. This makes unloading much easier.

The upper spray arm must not be blocked by items which are too big (e. g. cake slices)

The cutlery tray insert is removable.

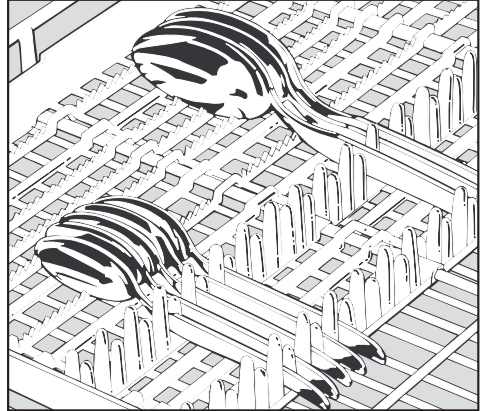

Place the handles between the holders. Spoon heads should be placed in contact with at least one of the serrated retainers on the base of the cutlery tray to ensure that water runs off them freely.

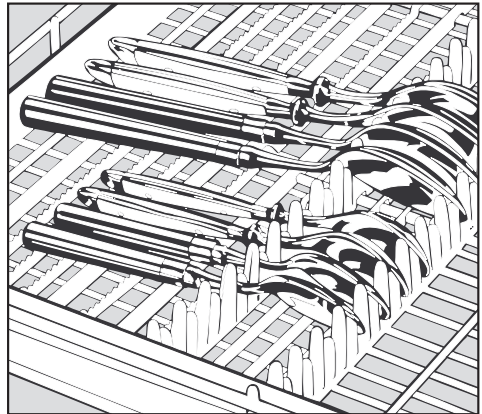

Spoons with round or oval handles should be placed with the heads in the holders as this prevents them slipping.

Items not suitable for dishwashers:

- Wooden cutlery and crockery or items with wooden parts: these may discolour and fade. The glue used in these items is not dishwasher-proof and wooden handles may come loose after being washed in a dishwasher.
- Craft items, antiques, valuable vases and decorative glassware are also not suitable for dishwashers.
- Plastic items which are not heat resistant may lose shape.
- Copper, brass, tin and aluminium items may discolour or become matt.
- Items with colours painted over a glaze may fade after many washes.
- Clouding may occur on glasses after frequent washing. Do not wash glassware containing lead crystal in a dishwasher.

We recommend:

- When purchasing new crockery and cutlery, make sure they are dishwasher-proof.
- There are no standard guidelines for washing glassware. When in doubt, wash by hand.
- If delicate glassware is washed in the dishwasher ensure that only very low temperatures are used (see programme chart). This will reduce the risk of clouding.

Please note

Silverware previously cleaned with a silver polish may still be damp or spotted at the end of a programme, where water has not run off smoothly. It may need rubbing dry with a soft cloth. Silver treated in a silver immersion dip is usually dry at the end of a programme but may discolour.

Aluminium components (e. g. a grease filter) must not be cleaned with caustic alkaline commercial or industrial cleaning agents. These may damage material, or in extreme cases, cause severe chemical reaction.

See section “Adding detergent” for information on suitable detergents.

Operating the dishwasher

Adding detergent

Only use detergents formulated for domestic dishwashers. Do not use washing up liquid.

- You can use conventional powder detergent, tablets or liquid dishwasher detergent.
- Put powder or liquid detergent into the dispenser compartment.
- Detergent tablets should only be put into compartment II if this is recommended by the manufacturer. If the manufacturer recommends inserting tablets in the cutlery basket do not do so. Instead place them on the inside of the door or directly into the wash cabinet. The tablets will then dissolve completely.

Detergent manufacturers give the required amount of detergent for a particular programme on their packaging.

- Use at least 30 ml of detergent for a full load in the following programmes:
 - Normal programme,
 - Universal programme,
 - Universal plus programme,
 - Economy 45° C programme.If the manufacturer recommends a larger amount of detergent, use the amount recommended.

Please note

Failure to dispense the recommended amount of detergent may impair cleaning results.

There are currently three types of detergent on the market:

1. Detergents containing phosphates and chlorine.
2. Detergents containing phosphates but chlorine-free.
3. Phosphate-free and chlorine-free detergents.

Type 3 detergents are more environmentally friendly, however:

Phosphate-free detergent reacts more sensitively to water hardness than detergent containing phosphates. This may influence cleaning results.

The following problems may occur:

- Increased etching in the form of a bluish sheen on the surface of glassware
- Discolouration of silverware
- Colours painted over a glaze may fade.

Appearances of this nature are generally caused by the detergent used and are not attributable to any malfunctioning of the dishwasher itself.

Preventative measures:

- Try out a phosphate-free detergent from another manufacturer.
- Change to a detergent containing phosphates (type 2), or, if available, to a detergent containing both phosphates and chlorine (type 1).
- Programme the water hardness selector one setting higher than recommended for your supply hardness (see chart in “Before using for the first time”). Softer water is then provided.

Operating the dishwasher

The bleaching effect of chlorine-free detergents is lower than that of detergents containing chlorine. This may result in increased tea stains or discolouration on plastic items. Appearances of this nature are generally caused by the detergent used and are not attributable to any malfunctioning of the dishwasher itself.

Preventative measures:

- Increase the amount of detergent used for a greater bleaching effect.
- If available, change to a detergent containing chlorine (type 1).

Should you experience difficulties when using these types of products, please contact the detergent manufacturer's advisory service.

Warning:

Avoid inhalation of powder detergents. Dishwasher detergents contain irritant or corrosive ingredients. They can cause burning in the mouth and throat if swallowed, or inhibit breathing. Consult a doctor immediately if detergent has been swallowed or inhaled.

Keep children away from detergents and from the dishwasher when the door is open. There could still be detergent residues in the cabinet.

To avoid the danger of children coming into contact with the dishwasher detergent only add detergent just before starting the programme and close the door, activating the child safety lock.

To achieve optimum results distribute the required amount of detergent, depending on the type of detergent and the programme selected, proportionally between compartments I and II of the dispenser.

It is essential to follow the instructions given in the programme chart at the end of the operating instructions.

Operating the dishwasher

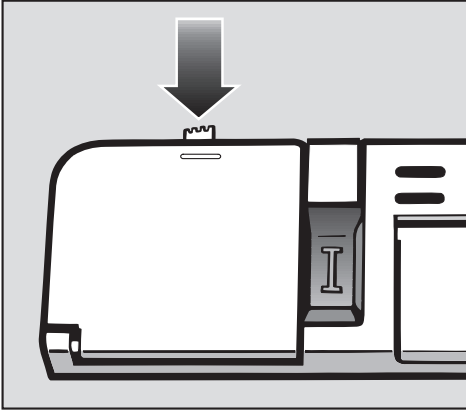

For information

Compartment I holds max. 25 ml.
Compartment II holds max. 80 ml.

There are markings in compartment II to assist with dispensing. The marks indicate a level of approx. 20, 25, 30 ml when the door is open in a horizontal position.

- Press the opening catch on the detergent dispenser. The flap will spring open.

The flap is always open at the end of a programme.

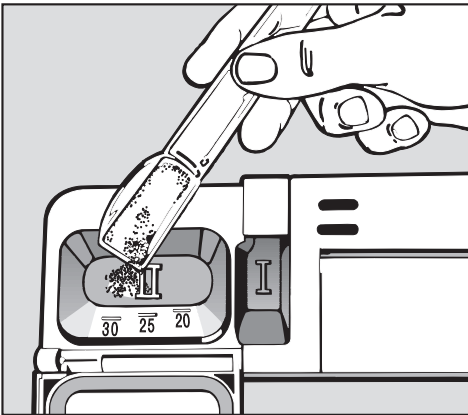

- Add the required amount of detergent and close the flap.
- Ensure that the detergent package is properly sealed after use. Otherwise the detergent can lose its effectiveness.

Programme selection

Choose your programme according to the type of load and how dirty it is.

In most cases this will be a Normal Programme, a Universal Programme or a Universal Plus Programme.

These programmes are ideally suited to everyday mixed loads with varying degrees of soiling.

The different programmes and their uses are described in the programme chart at the end of this booklet.

Operating the dishwasher

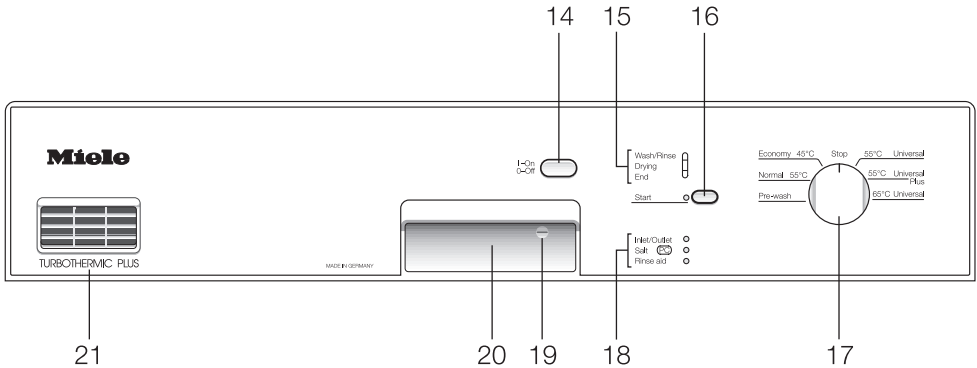

Switching on

- Check whether the spray arms can rotate freely.
- Close the door.
- Open the stopcock (if it is closed).
- Press the “On/Off” button (14).

The “Start” indicator light (16) comes on.

Starting a programme

- When selecting a programme, refer to the programme chart at the end of the operating instructions.
- Turn the programme selector (17) clockwise or anti-clockwise to the required programme.
- Press the “Start” button (16).

The programme cycle begins. The “Start” indicator light (16) goes out and the “Wash/Rinse” indicator light (15) comes on.

Do not finish a programme prematurely. Important programme stages (e. g. reactivating the water softener) could be omitted.

Programme sequence indicator lights (15)

The “Wash/Rinse” indicator light comes on in the Pre-wash, Main wash, Interim rinse and Final rinse stages of a programme.

The “Drying” indicator light comes on during the Drying stage of a programme.

The “End” indicator light comes on when the programme has finished.

At the end of a programme

A programme has finished when the “End” indicator light comes on in the programme sequence display (15).

The dishwasher can now be opened and unloaded (see “Unloading the dishwasher”).

If the dishwasher is left closed, the fan will continue for a few more minutes to diminish any remaining moisture. This process is not part of the programme.

We recommend only opening the door immediately a programme has ended if you urgently need crockery or cutlery from it.

The running time of the fan can be increased to avoid the risk of damp air condensing on furniture fronts above the dishwasher. See “Drying fan running time” later in this section.

For safety's sake it is advisable to always switch the dishwasher off if you do not wish to start another programme immediately.

Switching off

At the end of a programme:

- Turn the programme selector (17) to “Stop”

The “End” indicator light (15) goes out and the “Start” indicator light (16) comes on.

- Press and release the “On/Off” button (14).

The “Start” indicator light (16) goes out.

The dishwasher continues to use electricity until switched off using the “On/Off” button.

If the dishwasher is not to be used for a longer period of time, e. g. whilst on holiday, it is recommended that the stopcock is turned off.

Operating the dishwasher

Interrupting a programme

A programme is interrupted as soon as the door is opened.

If the door is closed again, the programme will continue from the point it was at before the door was opened.

Warning:

Water in the dishwasher may be hot.

Danger of scalding!

Only open the door if absolutely necessary and exercise extreme caution when doing so. Before closing the door again, leave it ajar for approx. 20 secs. This will enable the temperature in the wash cabinet to settle. Close the door firmly making sure that it clicks into place.

Changing a programme

A programme can be changed at any time.

- Turn the programme selector switch to the new programme.

The new programme will start from the point the other programme was at when the programme was changed.

If, when changing a programme, you turn the programme selector past the "Stop" position, e. g. from "Economy 45°" to "Universal 55°", and the programme selector is on the Stop position for longer than one second, the programme initially selected will be cancelled (the "Wash/Rinse" indicator light (15) goes out and the "Start" (16) indicator light comes on). This also happens if the programme selector stands for longer than one second between "Universal 65°" and "Pre-Wash". The newly selected programme then starts from the beginning and you will have to press the "Start" button to commence the programme.

Drying fan running time

During drying and for 4 minutes after the end of a programme air passes through the ventilation outlet for the drying fan. To avoid the risk of this damp air condensing on furniture fronts above the dishwasher it is possible to extend the running time of the drying fan at the end of the programme from 4 minutes to 45 minutes.

To change the drying fan running time:

- Switch the appliance off with the “On/Off” button.
- Turn the programme selector to the “Stop” position.
- Press the “Start” button in and whilst doing so at the same time switch the dishwasher on using the “On/Off” button. Release the “Start” button again within two seconds.

The “Salt” indicator light will start flashing.

Note:

If a different indicator light is on or flashing, the process must be repeated.

Exception:

The “Rinse aid” indicator light will come on if you have not yet added rinse aid or if rinse aid needs replenishing.

- Turn the programme selector to the “Pre-wash” position.
 - If the “Start” indicator light does not come on: the fan running time is set to 4 minutes,
 - If the “Start” indicator light comes on: the fan running time is set to 45 minutes.
- Press the “Start” button to change the setting.

Depending on the previous setting the “Start” indicator light will either come on or go out.

- Turn the programme selector to the “Stop” position.
- Switch the appliance off with the “On/Off” button.
- The change is now stored in memory.

Operating the dishwasher

Unloading the dishwasher

- Dishes tend to break and chip more easily when they are hot.
Allow the dishes to cool until they are comfortable enough to handle before unloading them.
- If you open the door fully after switching off, the dishes will cool much faster.
- First unload the lower basket, then the upper basket and cutlery tray (depending on model).
This will prevent water drops from the upper basket and cutlery tray from falling onto the dishes in the lower basket.

Check your dishwasher regularly (approx. every 4 - 6 months). This way faults and problems can be avoided.

The dishwasher must not be used without all the filters in place.

Cleaning the filters in the wash cabinet

The filter combination in the base of the wash cabinet retains coarse soil from the suds solution, thus preventing it accessing the circulation system and re-entering the cabinet through the spray arms.

Collection of coarse soil may cause the filters to clog.

Check the filter combination regularly (every 4 - 6 months) and clean if necessary.

- Switch the dishwasher off beforehand.

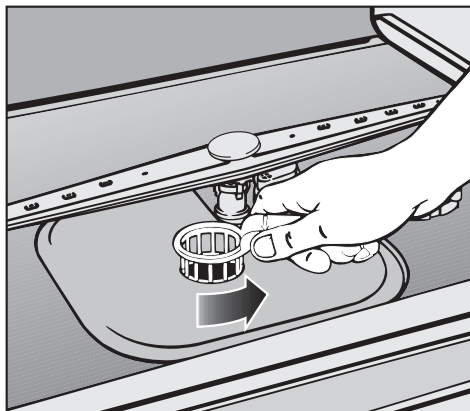

- Turn the handle anti-clockwise to release the filter combination.

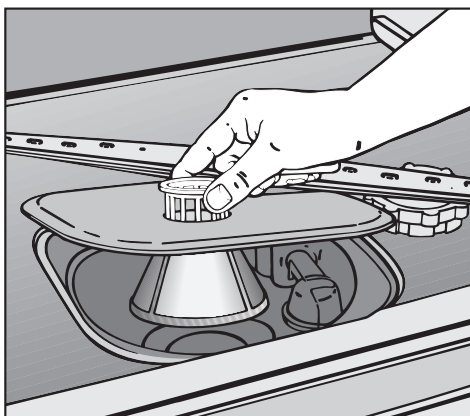

- Lift the filter combination out of the machine. Remove any coarse particles and rinse the filter under running water. Use a nylon brush if necessary.

Cleaning and care

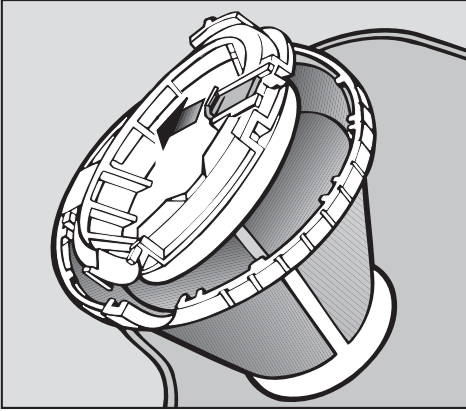

To clean the underside of the filter, the flap must be opened:

- Pull back the yellow clip to do this.
- Rinse all parts under running water, using a nylon brush if necessary.

Then close the flap so that the clip engages.

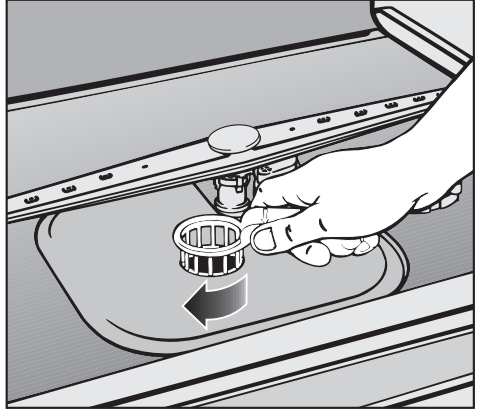

- Replace the filter combination so that it lies flat in the base of the wash cabinet.
- Secure the filter by turning the handle in a clockwise direction.

Important:
After cleaning make sure that the clip has properly engaged.

Cleaning the spray arms

Particles of food can get stuck in the spray arm jets. The spray arms should therefore be inspected and cleaned regularly (approx. every 4 - 6 months).

- Switch the dishwasher off beforehand.

Remove the spray arms as follows:

- Take out the cutlery tray (if your dishwasher is fitted with one).
- Press the top spray arm upwards to engage the inner ratchet. Then unscrew the spray arm.

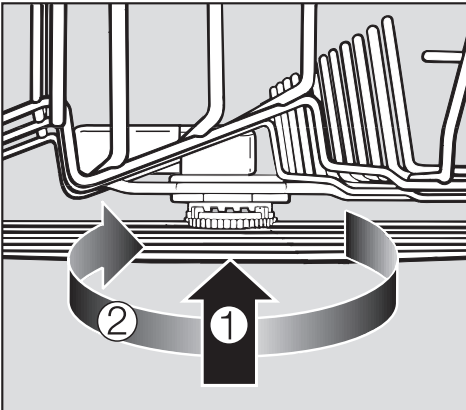

- Lift up the middle spray arm ① to engage the ratchet. Then unscrew the spray arm ②.

- Remove the lower basket.

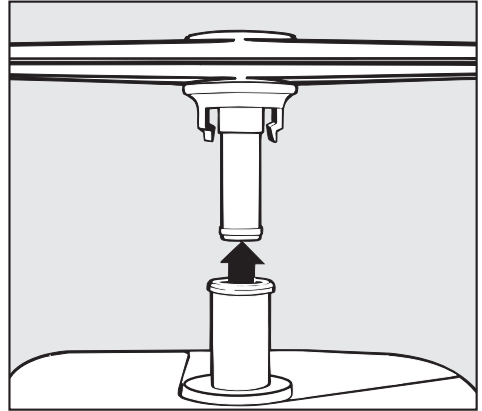

- Pull the lower spray arm firmly upwards to remove it.

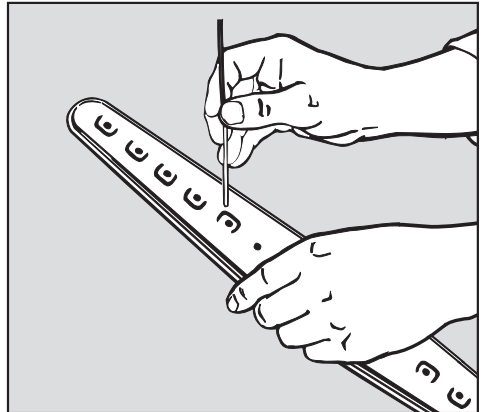

- Use a pointed object to push food particles into the spray arm jets.
- Rinse thoroughly under running water.
- Replace the spray arms and check that they rotate freely.

Cleaning and care

Cleaning the wash cabinet

The wash cabinet is largely self-cleaning, provided that the correct amount of detergent is always used.

If however there are lime scale or grease deposits in the cabinet these can be removed with a proprietary dishwasher cleaner.

Cleaning the door and the door seal

- Wipe the door seals regularly with a damp cloth to remove food deposits.
- Wipe food and drink residue from the sides of the dishwasher door. These areas are not part of the wash cabinet and are therefore not accessed by water from the spray arms.

Cleaning the control panel (fascia)

- This should only be wiped with a damp cloth or suitable cleaning agent designed for use on plastic.

Do not use abrasive cleaning agents, glass cleaning agents or all-purpose cleaners. Because of their chemical composition they could cause serious damage to plastic surfaces.

Cleaning the door panel

- Clean using a suitable cleaning agent.
- Panels made from wood should only be cleaned using a damp chamois leather and then dried with a soft cloth.

Do not use any cleaning agents containing ammonia or thinners. They could damage surfaces.

Problem solving guide

With the aid of the following guide, minor problems can be easily corrected without calling in a Miele service technician, thus saving you both time and money.

You should, however, note the following:

Repairs should only be carried out by a suitably qualified and trained person in accordance with local and national safety regulations. Unauthorised or incorrect repairs could cause personal injury or damage the machine.

Problem	Possible cause	Remedy
The “Start” indicator light does not come on after the machine has been switched on using the On/Off button.	The door is not properly closed.	Close the door firmly.
	The machine is not plugged in.	Insert the plug.
	The fuse is defective or has tripped.	Replace the fuse (U.K. fuse rating = 13 A).
The dishwasher does not start, after the “Start” button has been pressed; the “Start” indicator light comes on	The Programme selector is at the “Stop” position.	<ul style="list-style-type: none">– Turn the Programme selector to the required programme,– Press the “Start” button.
The dishwasher stops during a programme	The fuse has tripped.	Replace the fuse (U.K. fuse rating = 13 A).

Problem solving guide

Problem	Possible cause	Remedy
<p>The indicator light “Inlet/Outlet” is flashing and the programme does not continue</p>		<p>Before rectifying the problem you must:</p> <ul style="list-style-type: none"> – Turn the programme selector to the “Stop” position. – Switch the dishwasher off using the “On/Off” button.
	<p>Water intake is restricted.</p>	<ul style="list-style-type: none"> – Open the stopcock fully. – Check the water inlet filter and clean if necessary, see “Cleaning the water inlet filter”. – Check the water level and if necessary increase the water intake time, see “Increasing the water intake time”.
	<p>Water outlet is restricted. Water remains in the wash cabinet at the end of a programme.</p>	<ul style="list-style-type: none"> – Clean the filter combination, see “Cleaning and Care”. – Clean the drain pump. – Clean the non-return valve, see “Cleaning the drain pump and non-return valve”. – Remove any kink in the drain hose.

Problem solving guide

Problem	Possible cause	Remedy
<p>The “End” and “Start” indicator lights flash simultaneously</p>	<p>There may be a technical fault.</p>	<ul style="list-style-type: none"> – Turn the Programme selector to the “Stop” position. – Switch the dishwasher off using the “On/Off” button. <p>After a few seconds:</p> <ul style="list-style-type: none"> – Switch the dishwasher on using the “On/Off” button. – Turn the Programme selector to the required programme. – Press the “Start” button. <p>If the indicator lights flash again, there is a technical fault.</p> <ul style="list-style-type: none"> – Call the Miele Service Department. <p>Despite the problem the dishwasher can be used in all programmes. However the water will not heat up.</p>
<p>Knocking noise in the wash cabinet</p>	<p>The spray arm is knocking against an item in the basket.</p>	<p>Interrupt the programme, rearrange items which are obstructing the spray arms.</p>
<p>Rattling noise</p>	<p>Items of crockery are insecure in the wash cabinet.</p>	<p>Interrupt the programme, rearrange the items of crockery.</p>

Problem solving guide

Problem	Possible cause	Remedy
A whistling noise is heard during the programme	The axial face seal of the circulation pump sometimes makes a whistling noise. This may be caused by detergent.	This is not a problem. Try out other detergents. Consult the Miele Service Department if the noise is permanent.
Knocking noise in the water pipes	This may be caused by the on-site installation or the cross-section of the piping.	This has no influence on dishwasher function. If in doubt contact a suitably qualified plumber.
Dishes and glasses are not dry or are flecked	The rinse-aid amount set may be insufficient, or the rinse-aid reservoir empty.	Increase the dosage or replenish the reservoir, see "Before using for the first time".
	The water hardness level selector in the wash cabinet is set too high.	Set the selector to a lower setting, see "Programming and setting the water hardness level".
	Crockery was taken out of the cabinet too soon.	Leave it in for longer, see "Operating the dishwasher"
The dishes are not clean	The dishes were not loaded correctly. Dishes were placed inside other pieces, water could not access all surfaces.	See notes in "Loading the dishwasher".
	The outlet of the water intake pipe for the middle spray arm was covered. An insufficient amount of water flowed into the middle spray arm.	Make sure that dishes inserted in the rear section of the upper basket do not cover the pipe outlet.

Problem solving guide

Problem	Possible cause	Remedy
The dishes are not clean	The programme was not powerful enough.	Select a more intensive programme see “Programme chart” at the end of these operating instructions.
	Not enough detergent was dispensed.	Use more detergent, see “Operating the dishwasher”.
	Tall items are blocking the path of the spray arms.	Rearrange items so that the spray arms can rotate freely.
	The spray arm jets are blocked.	Clean the spray arm jets, see “Cleaning and care”.
	The filter combination in the base of the wash cabinet is not clean or is not correctly fitted. This may cause the spray arms jets to get blocked.	Clean and/or replace the filter combination correctly, Clean the spray arms, see “Cleaning and care”.
	The drain pump or non-return valve may be blocked.	Clean the drain pump and the non-return valve, see section on this.
	Too little water in the wash cabinet.	Check the water level and if necessary increase the water intake time, see sections on these.
Tea or lipstick stains have not been completely removed	The wash temperature of the selected programme was too low.	Select a programme with a higher wash temperature.
	The bleaching effect of the detergent used is too low.	Use detergent containing chlorine.

Problem solving guide

Problem	Possible cause	Remedy
White residue is visible on cutlery and crockery, clouding occurs on glassware; film can be wiped off	Not enough rinse aid was used.	Increase the dosage, see "Before using for the first time".
	There is no salt in the salt reservoir.	Add reactivation salt, see "Before using for the first time".
	The salt reservoir cap was not correctly screwed on.	Replace it making sure it screws back on correctly.
	The water softener is programmed to a setting which is too low.	Programme a higher setting, see "Before using for the first time".
	Phosphate-free detergent was used.	Try detergent containing phosphate.
Smearing appears on glassware and cutlery, there is a bluish sheen on the surface of glassware; film can be wiped off	The rinse aid dosage is set too high.	Reduce the dosage, see "Before using for the first time".
Glassware is dull and discoloured; film cannot be wiped off	The water hardness selector in the wash cabinet is incorrectly set.	Set it to the correct setting, see "Before using for the first time". There is no remedy for already damaged glassware.
	Glassware is not dishwasherproof. The surfaces are affected.	There is no remedy. Purchase glassware which is dishwasherproof.

Problem solving guide

Problem	Possible cause	Remedy
Plastic items are discoloured	Natural dyes e. g. from carrots, tomatoes or ketchup may be the cause. The amount of detergent used or its bleaching effect was not sufficient to deal with natural dyes.	Use detergent containing chlorine. Use more detergent, see "Operating the dishwasher". Discolouration is irreversible .
There are rust stains on cutlery	The salt reservoir cap has not been screwed on properly.	Screw the cap on firmly.
	The affected items are not corrosion resistant.	There is no remedy. Purchase cutlery which is dishwasher-proof.
The detergent dispenser lid cannot be closed properly	Clogged detergent residue is blocking the catch.	Remove the residue.
Detergent residue is left in the dispenser at the end of a programme	The dispenser was still damp when detergent was added.	Make sure the dispenser is dry before adding detergent.
Water remains in the wash cabinet at the end of a programme		Before rectifying the problem: <ul style="list-style-type: none"> – Turn the Programme selector to the "Stop" position. – Switch the dishwasher off using the "On/Off" button.
	The filter combination in the wash cabinet is clogged.	Clean the filter combination, see "Cleaning and Care"
	The drain pump or the non-return valve may be blocked.	Clean the drain pump and the non-return valve, see appropriate section.
	The drain hose is kinked.	Remove the kink.

Solving problems

Cleaning the water inlet filter

A filter is incorporated in the screw connection of the valve on the water inlet hose. The filter must be cleaned when dirty, otherwise insufficient water flows into the wash cabinet (see “Checking the water level”).

The plastic housing of the water connection contains an electrical component. It must not be dipped in water.

Recommendation

If the mains water contains a large number of insoluble substances, we recommend fitting a large-area filter in the connection between the stopcock and the water inlet hose threaded union.

This filter is available from the Miele Spares Dept.

Cleaning the filter:

- Disconnect the dishwasher from the mains supply (switch off at the mains socket, pull out the plug, switch off the appropriate circuit at the fuse box or withdraw the mains fuse).
- Turn off the stopcock.
- Unscrew the inlet hose.

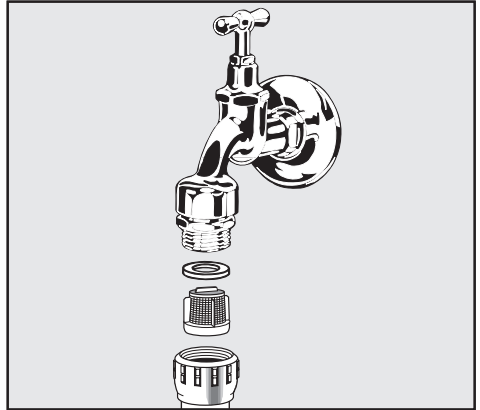

- Carefully remove the rubber seal.
- Withdraw the filter using pointed pliers and rinse clean under running water.
- Replace the filter and seal, making sure they are sitting correctly.
- Screw back into place on the water inlet, taking care that it is not cross-threaded.
- Turn on the stopcock gradually to test for leaks. If there is a leak, screw the connections on more tightly, making sure the threads do not cross.

Checking the water level

If the water pressure (flow pressure at the take-off point) is less than 1.0 bar, too little water will flow into the wash cabinet and the dishes will not be cleaned properly.

To check whether sufficient water flows into the wash cabinet:

- Turn on the stopcock fully.
- Run the “Pre-wash” programme (without crockery) once to get water flowing throughout the machine.
- Start the “Pre-wash” programme again.
- After approx. three minutes open the door and remove the bottom basket from the machine.

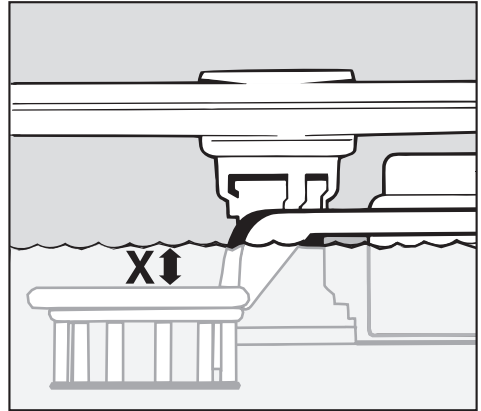

The water level is correct when the water level (dimension “X”), is at least 4 mm above the coarse filter in the middle of the filter combination.

If it measures less, then either the water inlet filter must be cleaned (see previous page) or the water intake time increased (see following page).

Solving problems

Increasing the water intake time

If the water pressure is lower than 1.0 bar, too little water will flow into the wash cabinet (see “Checking the water level”). In this case the water intake time must be increased.

Proceed as follows:

- Switch the dishwasher off using the “On/Off” button.
- Turn the programme selector to “Stop”.
- Press the “Start” button in and whilst doing so at the same time switch the dishwasher on using the “On/Off” button. Release the “Start” button again within two seconds.

The “Salt” indicator light will start flashing

Note:

If a different indicator light is on or flashing, the process must be repeated.

Exception:

The “Rinse aid” indicator light will come on if you have not yet added rinse aid or if rinse aid needs replenishing.

- Turn the programme selector to the “Economy 45°” setting.
- If the “Start” indicator light does not come on, then the water intake time is set to the standard time,
- If the “Start” indicator light comes on: then the water intake time is set to increased intake time.
- Press the “Start” button to change the setting.

Depending on the previous setting, the “Start” indicator light will either come on or remain switched off.

- Turn the programme selector to the “Stop” position.
- Switch the dishwasher off using the “On/Off” button.

The modified water intake time is now stored in memory.

Cleaning the drain pump and non-return valve

If the water has not been pumped away at the end of a programme the drain pump or the non-return valve might be blocked. They are, however, easy to clean. Watch out for glass or bone splinters which could cause injury.

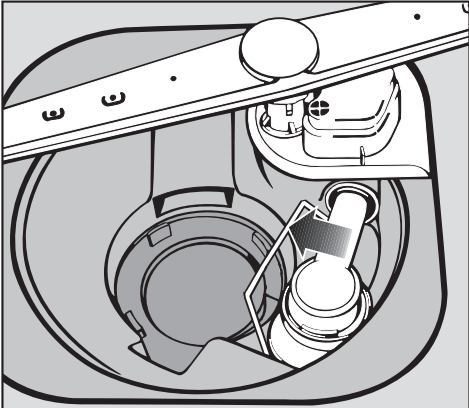
- Take the filter combination out of the wash cabinet (see “Cleaning and care”, “Cleaning the filters in the wash cabinet”).
 - Scoop the water out of the cabinet using a suitable container.
- 
- The diagram shows a top-down view of the internal components of a washing machine's drain system. A metal locking clamp is positioned over a circular non-return valve. To the left, the drain pump is visible, connected to a network of pipes. The entire assembly is housed within a plastic cabinet structure.
- Raise the locking clamp for the non-return valve.

Solving problems

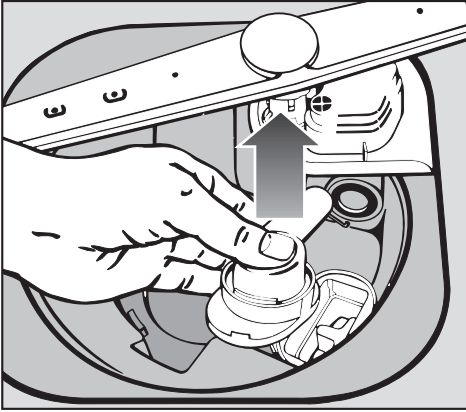

- Lift up the non-return valve and rinse well under running water.
- Remove all extraneous objects from the non-return valve.

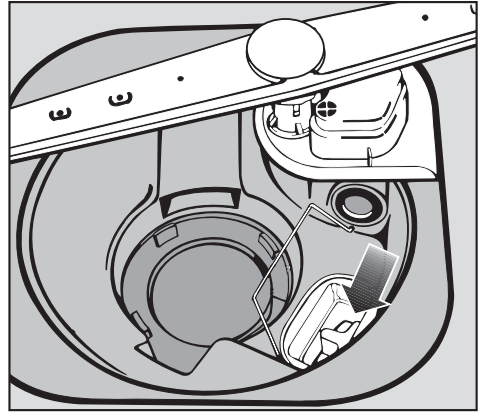

The drain pump is situated under the non-return valve (see arrow).

- Remove all extraneous objects from the drain pump (watch out for glass or bone splinters which are particularly difficult to detect and could cause injury). Turn the drain pump impeller by hand to check that there are no more obstructions.
- Carefully replace the non-return valve and secure it with the locking clamp.

Should you still have any difficulties, please contact:

- Your Miele Dealer
- or
- The Miele Service Department

See back cover for addresses.

- Please quote the model type and number of your appliance.

This information can be found on the data plate at the top of the door.

Please note that telephone calls may be monitored and recorded to improve our service.

Programme update function - PC

The programme update function enables new developments in programme technology to be programmed into your machine by a service technician.

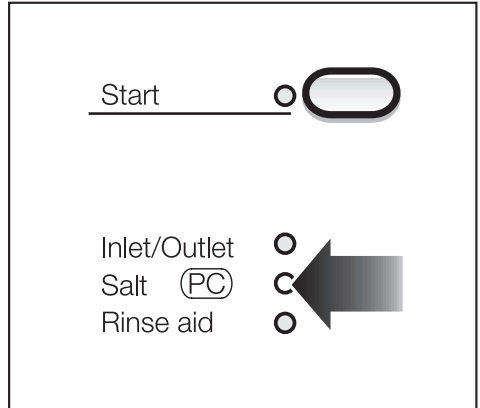

When, for example, technological developments offer advanced modifications to your existing programme cycles a service technician will be able to input these into your machine controls via the indicator light marked PC (Programme Correction).

Miele will provide information on programme updates when such developments become available.

Special accessories

To make the most of your dishwasher

You would like...	then you need...
... to wash bottles, e. g. milk or baby bottles	... a bottle holder
... to wash long-stemmed glassware	... a glassware insert for the upper basket

Test standard: IEC 436 / DIN 44990 / IEC 704 / prEN 50242

Programme tested: **Universal Plus 55 °**
Programme with best cleaning and drying results and for noise emissions

Standard programme for Energy label: Economy 45 °

Amount washed: 12 place settings

Amount of detergent: If using a detergent containing chlorine:
5 g in compartment I and 25 g in compartment II.
If using a chlorine-free detergent:
30 g only in compartment II.

Rinse aid dispensing: Setting 3 (approx. 3 ml, set at factory)

Water hardness level selector: Setting 0

Noise measurements: Before starting a programme to measure noise, the dishwasher door must first be opened completely, and then closed. Doing this will automatically close the ventilation outlet for the Turbothermic process.

Dishwashers with cutlery basket

Spoon inserts: Fit the two inserts on top of the cutlery basket (see section on loading the dishwasher, spoon inserts). Place six spoons at intervals in each insert.

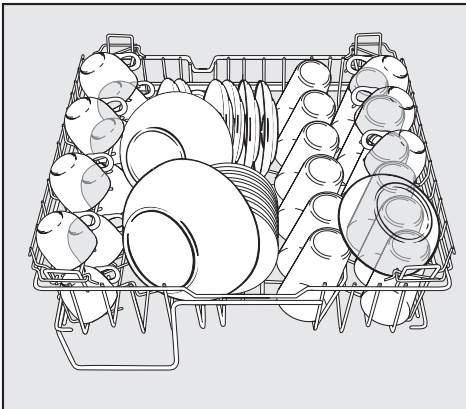

Upper basket

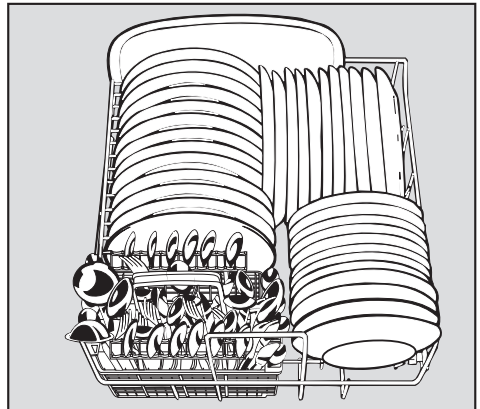

Lower basket

Comparison tests

Dishwashers with cutlery tray

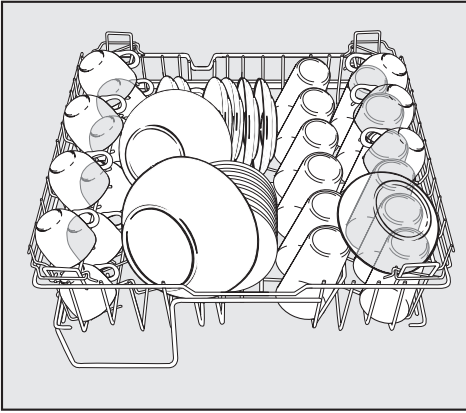

Upper basket

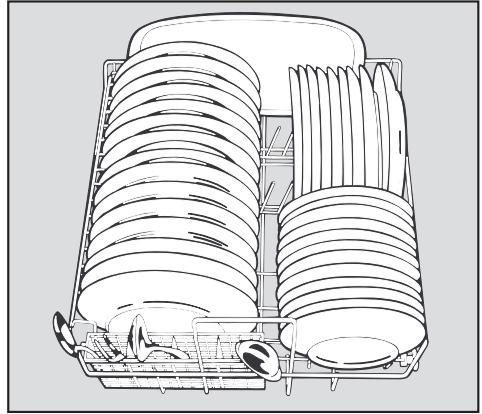

Lower basket

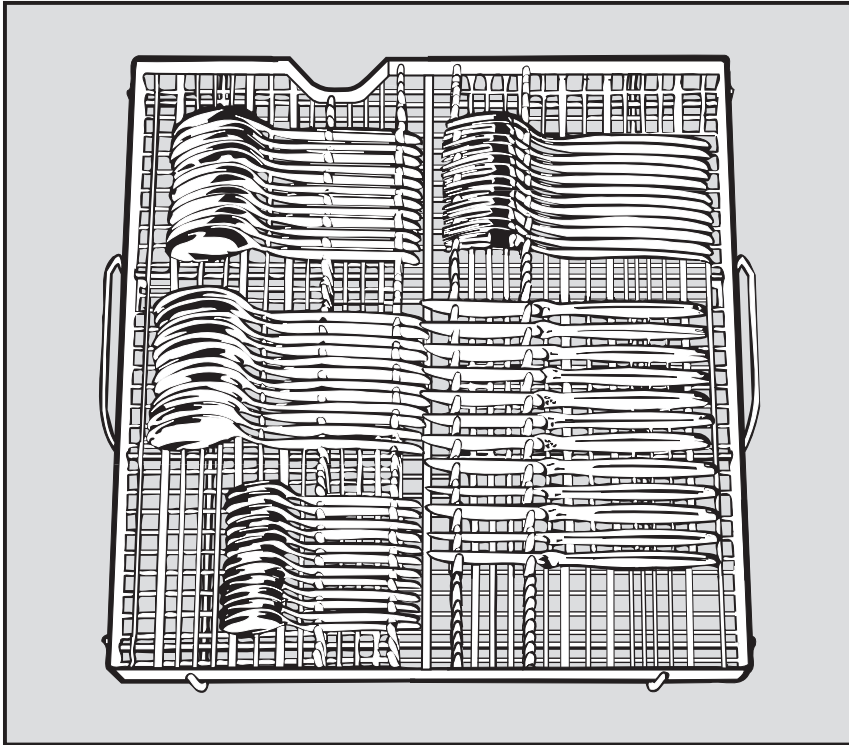

Cutlery tray

Should you ever need to move the dishwasher, e.g. when moving house, note the following:

- Empty the dishwasher,
- Secure any loose parts, e. g. hoses, cables, cutlery baskets,
- Transport the dishwasher in the upright position.

If unavoidable it may be transported on its back.

Do not transport it on its side or on the door as residual water still in the machine will leak out of it.

This residual water could get into the electronic unit and cause a fault.

Programme chart

Programme	When to use	Detergent		
		chlorine free ¹⁾	containing chlorine ²⁾	
			Compartment II (Wash cycle)	Compartment I (Pre-wash)
Universal 55 °	for normal everyday loads	100 %	20 %	80 %
Universal Plus 55 ° ³⁾	as Universal 55 °, but with longer wash time for heavily soiled loads, also suitable for chlorine-free detergents	100 %	20 %	80 %
Universal 65 °	as Universal 55 °, but at a higher temperature for stubborn dried on particles	100%	20 %	80 %
Normal 55 °	for normal everyday loads, also suitable for chlorine-free detergents	100 %		100 %
Economy 45 ° ⁴⁾	for normal everyday loads, energy saving programme	100 %		100 %
Pre-wash	for rinsing crockery to avoid smells, if a complete cycle is not yet needed			

The dispensing method will depend on the type of detergent being used.

1) Use this ratio for:

- detergent which is chlorine and phosphate free
- detergent which is chlorine free but contains phosphates
- liquid dishwasher detergent

In this instance the whole amount is placed in compartment II.

2) Use this ratio for:

- powder detergent which contains chlorine and phosphates (but not liquid detergent)

Divide the total amount, as shown, between compartment I and compartment II.

When washing a full load in the Normal Programme, the Universal Programme, the Universal Plus Programme or the Economy Programme at least 30 ml of detergent are required. If the detergent manufacturer recommends using more than this you should dispense the amount they suggest.

3) Standard programme for comparison tests (see section "Comparison tests")

4) Standard programme for Energy label

Programme chart

Programme cycle						Consumption			Duration	
						Energy	kWh	Water	Minutes (approx.)	
1. Preliminary pre-wash	2. Pre-wash	Main wash	Interim rinse	Final rinse	Drying	Cold water connection (15 °C)	Hot water connection (55 °C)	Litres	Cold water (15 °C)	Hot water (55 °C)
	X	X 55 °	X	X 65 °	X	1.20	0.6	18	85	72
	X	X 55 °	X	X 65 °	X	1.25	0.7	18	108	95
	X	X 65 °	X	X 65 °	X	1.30	0.7	18	88	74
		X 55 °	X	X 65 °	X	1.20	0.6	14	80	67
		X 45 °	X	X 55 °	X	1.05	0.6	14	115	102
	X					0.06	0.06	5	11	11

N.B. Data obtained from a machine tested in Germany.

Technical data

Dishwasher model

G 349

Height	84.5 cm (adjustable + 5.0 cm)
Height of building in recess	87.5 - 89.5 cm
Width	54.7 cm
Width of building in recess	56.2 - 56.8 cm
Depth	57 cm
Depth with door open	120.5 cm
Weight	
Integrated model	approx. 52 kg
Integrated model SC#	approx. 54 kg
Voltage	} see data plate at the top of the door
Rated load	
Fuse rating	
Test marks	VDE, Radio and television suppressed
Water pressure (flow pressure)	1.0 - 10 bar pressure
Hot water connection	max. 60 °C
Delivery head	max. 1 m
Drainage length	max. 4 m
Connection cable	approx. 2.65 m
Capacity	12 place settings

SC = Dishwasher with cutlery tray



United Kingdom:

Miele Co. Ltd.

Fairacres, Marcham Road, Abingdon, Oxon, OX14 1TW

tel. Abingdon (01235) 554455 - fax (01235) 554477

Service Office, tel. Abingdon (01235) 554466

Ireland:

Miele Ireland Limited

Broomhill Business Complex, Broomhill Road, Dublin 24

Tel. (01) 46 10 710, Fax (01) 46 10 797