

Honeywell

**Heating/Cooling
Thermostat and Subbase
Package**

T8196A/Q682A

OWNER'S MANUAL

Congratulations on your purchase of a Honeywell energy saving thermostat. The Honeywell name is your assurance of accurate control and reliable operation for years to come.

During heating and cooling, this thermostat will automatically lower and raise the temperature in your home one or more times every 24 hours. This allows you to significantly lower your fuel costs, while awakening (or returning home) to a comfortable temperature.

Read this manual to learn how to use your new thermostat.

Recycling Notice

This control contains mercury in a sealed tube. Do *not* place control in the trash at the end of its useful life.

If this control is replacing a control that contains mercury in a sealed tube, do *not* place your old control in the trash.

Contact your local waste management authority for instructions regarding recycling and the proper disposal of the control, or of an old control containing mercury in a sealed tube.

If you have questions, call Honeywell Inc. at 1-800-468-1502.

Table of Contents

	PAGE
Features Of Your Thermostat	4
Setting The Temperature	6
Inserting Timer Batteries	7
Setting The Timer	8
Programming	9
Troubleshooting	12
Warranty	19

Features Of Your Thermostat

- ① **FLIP-UP COVER.** Lift it up to set timer for energy savings and comfort temperature periods.
- ② **THERMOSTAT COVER.** Lift up to show timer.
- ③ **THERMOMETER.** Provides room temperature reading.
- ④ **TEMPERATURE SETTING LEVERS** Left (blue mark) controls the low temperature, right (red mark) controls the high temperature.
- ⑤ **TIMER.** This timer provides a 24-hour slotted dial to hold the programming pins.
- ⑥ **TIMER SETTING KNOB.** Turn clockwise to match the correct AM or PM time to the time indicator.
- ⑦ **TIME INDICATOR.** Arrow head indicates time for 24-hour dial.
- ⑧ **PROGRAM INDEX WHEEL.** Controls high

and low temperature at specific time of day as set by program pins.

- ⑨ **PROGRAM PINS.** Must be inserted into 24-hour timer dial slots to control program index wheel.

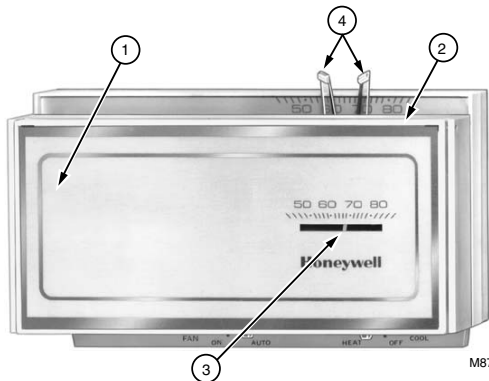

M8723

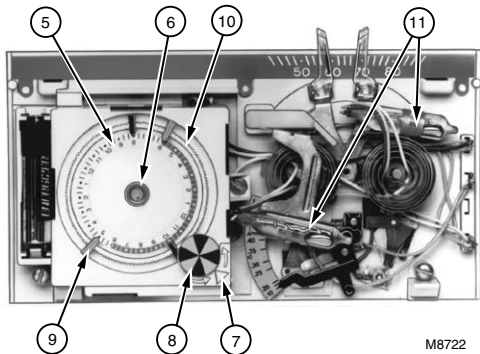

M8722

- ⑩ PIN SLOTS. Located on 24-hour dial at 10-minute intervals for program pin insertion.
- ⑪ MERCURY BULB AND BIMETAL ELEMENT (2). Provide automatic temperature control by switching the heating or cooling system on and off.

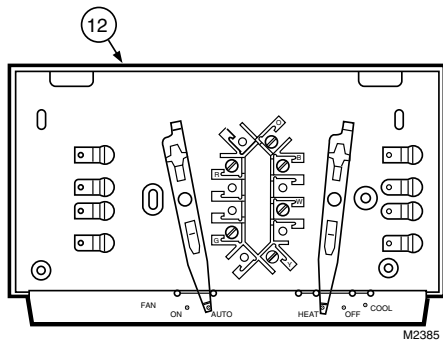

M2385

- ⑫ SUBBASE. Provides mounting base, wiring connections and manual switching control for heating/cooling thermostat.

Setting The Temperature

For Heating

Set the left lever (blue mark) to the energy savings temperature you want when you are sleeping or your home is unoccupied.

Set the right lever (red mark) to the temperature you want for comfort periods.

NOTE: You may bypass the time program by setting both the red and blue levers to the same temperature set point.

For Cooling

Set the left lever (blue mark) to the temperature you want for comfort periods.

Set the right lever (red mark) to the energy savings temperature you want when you are sleeping or your home is unoccupied.

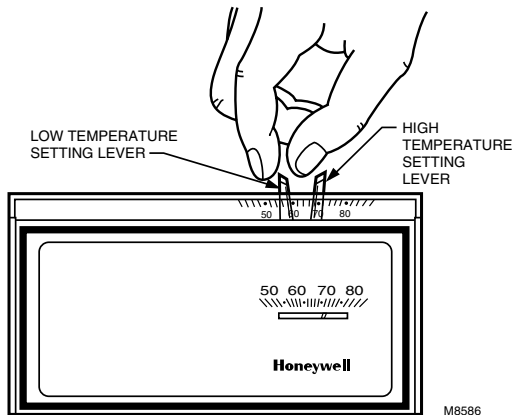
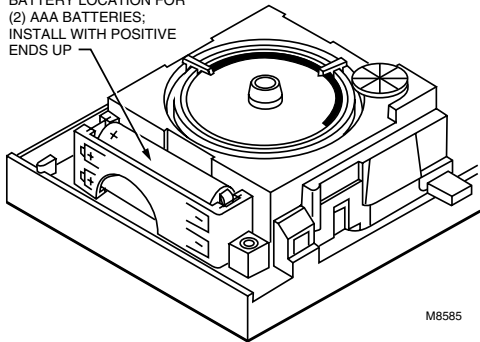

Fig. 1—Setting high and low temperature levers.

Inserting Timer Batteries

Power is supplied to the timer by two AAA alkaline batteries (not included). Install the batteries in the thermostat as shown in Fig. 2. Once a year or when batteries are dead, replace with two new AAA alkaline batteries. We recommend Energizer® batteries.

BATTERY LOCATION FOR
(2) AAA BATTERIES;
INSTALL WITH POSITIVE
ENDS UP



M8585

Fig. 2—Inserting timer batteries.



Setting The Timer

Lift thermostat flip-up cover, and you'll find the 24-hour program dial, slotted in ten-minute increments. Adjust the timer to the current time by carefully turning the knob clockwise . DO NOT reverse the knob.

When time is correctly set, the Time Indicator Arrow (See Fig. 3) will point to the correct time and corresponding daytime (light) or nighttime (dark) band of the program dial.

EXAMPLE: For 11 PM, the time indicator arrow will point directly to dark band on dial. For 11 AM, the arrow will point to light band on dial.

Daylight Savings Time

When Daylight Savings Time starts, carefully move the knob clockwise  one hour. When Daylight Savings Time ends, carefully move the knob clockwise  23 hours. DO NOT reverse the knob.

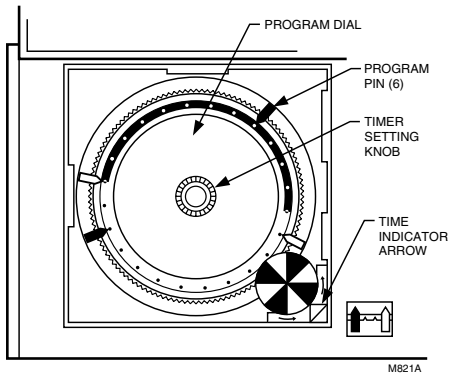

Fig. 3—Setting the timer.

Programming

You can program your thermostat to automatically lower and raise the temperature one or more times every 24 hours.

Before Setting Your Program

Lift thermostat flip-up cover and you'll find the 24-hour program dial. The slots on the program dial (Fig. 4) are for the program pins which can be inserted at ten-minute intervals.

Three red and three blue program pins are included with your thermostat. The red pins start the high-temperature period; the blue pins start the low-temperature period. A heating program was preprogrammed. A red pin is inserted at 6:00 AM for high temperature (comfort period); a blue pin is inserted at 10:00 PM for low temperature (energy saving period). Two additional sets of pins are located in the program pin storage area.

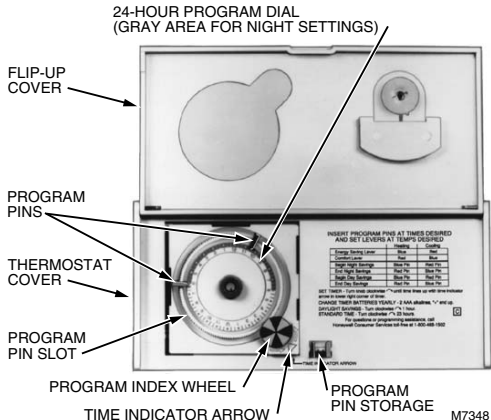

Fig. 4—Program components.

You can set up to six temperature changes with the pins supplied. We recommend at least five hours for each energy savings period.

To change the pins or add a new energy savings period—

- To insert a pin, push it straight into the selected notch on the program dial until it is completely seated.
- To remove a pin, press against program dial and pull the pin straight out. **DO NOT** attempt to change a pin if it is engaged with the program index wheel.
- On heating-cooling systems, you must remove the program pins from the heating program to set new times for your cooling program. Write down your colors and time for reprogramming at the next heating season. Also, you may want to change the temperature setting lever positions.

Setting the Heating Program

Decide when you want the temperature to reach the comfort level. Find the notch on the program dial that is one-half hour before this time and insert a red pin. The half-hour head start gives the furnace time to heat the house before you wake up or arrive home.

		WINTER			SUMMER 		
		TEMPERATURE		PROGRAM PIN IN CONTROL	TEMPERATURE		PROGRAM PIN IN CONTROL
		°F	°C		°F	°C	
NIGHT ENERGY SAVING PERIOD	BEGINS 10:00 PM	58	14	BLUE	80	27	RED
	ENDS 6:00 AM	68	20	RED	75	24	BLUE
DAY ENERGY SAVING PERIOD	BEGINS 7:30 AM	58	14	BLUE	80	27	RED
	ENDS 4:00 PM	68	20	RED	75	24	BLUE



NOT APPLICABLE ON HEATING-ONLY MODEL.

M8677

Fig. 5— Program examples.

Decide when you want the energy savings period to start and insert a *blue* pin at the notch that corresponds to this time. After the blue pin engages, the furnace will be off until room temperature drops to the energy savings set point.

You can set both a day and night program. See Fig. 5. for program examples.

Setting the Cooling Program

Decide when you want the temperature to reach the comfort level. Find the notch on the program dial that is one-half hour before this time and insert a *blue* pin. The half-hour head start gives the air conditioner time to cool the house before you wake up or arrive home.

Decide when you want the energy savings period to start and insert a *red* pin at the notch that corresponds to this time. After the red pin engages, the air conditioner will be off until room temperature rises to the energy savings setpoint.

Troubleshooting

Your Honeywell thermostat requires little or no attention. Most problems can generally be traced to the following:

Problem	Check	Action
No heat.	— system switch. May be in OFF or COOL position.	Move system switch to HEAT position.
	— fuse or circuit breaker.	If blown or tripped, replace fuse or reset breaker.
	— furnace power switch. May be Off.	Move switch to ON.
	— pilot flame. May be out.	Relight pilot flame per furnace manufacturers instructions.
	— R and W thermostat connections.	Turn Off power to furnace. Check for correct terminal hookups. Repair any frayed or broken wires. Firmly tighten all terminal screws. Turn On power.

(continued)

Troubleshooting (continued)

Problem	Check	Action
No heat <i>(continued)</i> .	— other problem.	Contact a qualified service technician for assistance.
Energy savings temperature program 12 hours off.	— program dial for proper day or night phase.	Turn timer ahead 12 hours. Move setting knob clockwise  only.
Rooms do not warm up at programmed time.	— timer program for heating system. May need more time to warm up rooms.	Move red pin one-half hour earlier on the program dial.
Temperature change occurs at the wrong time.	— programs pins for correct time locations.	Relocate pins to desired settings.
Room temperatures are not correct.	— positions of thermostat setpoint levers.	Reset to desired temperatures.
	— position of subbase system switch.	Move to desired operating position.

(continued)

Troubleshooting (continued)

Problem	Check	Action
Room temperatures are not correct <i>(continued)</i> .	— thermostat circuits.	HEATING/COOLING SYSTEM—With system switch at HEAT, move temperature setting levers 5°F (3°C) above room temperature. Heating system should start. With system switch at COOL, move temperature setting levers 5°F (3°C) below room temperature. Cooling system should start. IF THE SYSTEMS DO NOT OPERATE, CALL A QUALIFIED TECHNICIAN.
No cooling.	— system switch. May be in OFF or HEAT position.	Move switch to COOL position.
	— fuse or circuit breaker.	If fuse is blown or breaker tripped, replace or reset.
	— condenser switch position. Located outdoors and may be turned OFF.	Move to ON position.

(continued)

Troubleshooting (continued)

Problem	Check	Action
No cooling (continued).	— Y and R thermostat connections.	Turn Off power to cooling system. Check for correct terminal hookups. Repair any frayed or broken wires. Firmly tighten all terminal screws.
	— other problems.	Contact a qualified service technician for assistance.
Timer is losing time.	— batteries. May be dead.	Replace with two new AAA alkaline batteries as shown on page 7.
Thermostat setting and thermometer reading disagree.	— level position of thermostat.	Reinstall thermostat subbase. Use a spirit level.
	— area around thermostat for drafts or radiant heat.	Thermostat should be about 5 ft (1.5m) above floor on an inside wall. Contact qualified service technician for change of location.
	— calibration of thermometer.	See instructions on page 16.

If Troubleshooting section has not solved the problem, call a qualified service technician or Honeywell Customer Assistance Center at 1-800-468-1502, Monday - Friday, 7:00 AM to 5:30 PM, Central time, for additional assistance.

Servicing The Thermostat

Cycle Rate Adjustment

The equipment should cycle on and off just enough to keep the room temperature close to the temperature lever settings.

If the thermostat seems to cycle the heating system too fast or too slow, adjust the cycle rate by moving the anticipator setting lever one indicator mark at a time (Fig. 6). Observe the heating system operation after each adjustment.

NOTE: Most hot water systems require a setting of 1.2A.

Thermometer Adjustment

The thermometer has been accurately calibrated at the factory and should only need adjustment if it was mishandled.

If the set point lever and the thermometer reading do not agree, follow the procedure on the next page.

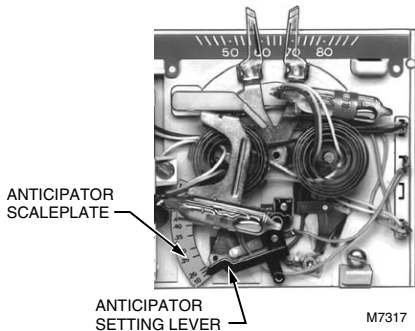

Fig. 6—Heat anticipator setting.

Remove thermostat cover and open the flip-up cover.

Set the thermostat cover on a table near thermometer of known accuracy.

Allow at least five minutes for cover thermometer to sense area temperature, then compare the readings. Be careful not to touch thermometer or breathe on it.

If the readings are the same, replace cover and put the system into operation.

If the readings are different, insert a small screwdriver in the thermometer slot, shown in Fig. 7, and turn it until both thermometers read the same.

Replace thermostat cover and put the system into operation.

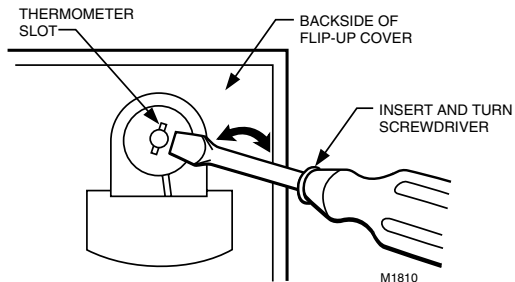

Fig. 7—Thermometer adjustment.

If you have questions regarding the installation and programming of your Honeywell thermostat, please contact the Honeywell Customer Assistance Center at 1-800-468-1502, Monday - Friday, 7:00 AM to 5:30 PM, Central time. Before you call, please have the following information available: make and model of furnace, thermostat, and air conditioner.

Limited One-Year Warranty

Honeywell warrants this product to be free from defects in the workmanship or materials, under normal use and service, for a period of one (1) year from the date of purchase by the consumer. If, at any time during the warranty period, the product is defective or malfunctions, Honeywell shall repair or replace it (at Honeywell's option) within a reasonable period of time.

If the product is defective,

- (i) return it, with a bill of sale or other dated proof-of-purchase, to the dealer or contractor from which you purchased it, or
- (ii) package it carefully, along with proof-of-purchase (including date of purchase) and a short description of the malfunction, and mail it, postage prepaid, to the following address:

Honeywell Inc.
Return Goods Department
1050 Berkshire Lane
Plymouth, MN 55441-4437

This warranty does not cover removal or reinstallation costs. This warranty shall not apply if it is shown by Honeywell that the defect or malfunction was caused by damage which occurred while the product was in the possession of a consumer.

Honeywell's sole responsibility shall be to repair or replace the product within the terms stated above. HONEYWELL SHALL NOT BE LIABLE FOR ANY LOSS OR DAMAGE OF ANY KIND, INCLUDING ANY INCIDENTAL OR CONSEQUENTIAL DAMAGES RESULTING, DIRECTLY OR INDIRECTLY FROM ANY BREACH OF ANY WARRANTY, EXPRESS OR IMPLIED, OR ANY OTHER FAILURE OF THIS PRODUCT. Some states do not allow the exclusion or limitation of incidental or consequential damages, so this limitation may not apply to you.

THIS WARRANTY IS THE ONLY EXPRESS WARRANTY HONEYWELL MAKES ON THIS PRODUCT. THE DURATION OF ANY IMPLIED WARRANTIES, INCLUDING THE WARRANTIES OF MERCHANTABILITY AND FITNESS FOR A PARTICULAR PURPOSE, IS HEREBY LIMITED TO THE ONE YEAR DURATION OF THIS WARRANTY. Some states do not allow limitations on how long an implied warranty lasts, so the above limitation may not apply to you.

This warranty gives you specific legal rights, and you may have other rights which vary from state to state.

If you have questions concerning this warranty, please write our Customer Assistance Center, Honeywell Inc., P.O. Box 524, Minneapolis, MN 55440-0524 or call 1-800-468-1502, Monday - Friday, 7:00 a.m. to 5:30 p.m., Central time.

Honeywell

Automation and Control Solutions

Honeywell International Inc.	Honeywell Limited—Honeywell Limitée
1985 Douglas Drive North	35 Dynamic Drive
Golden Valley, MN 55422	Scarborough, Ontario M1V 4Z9

D.F. ©Honeywell Inc. 1994 Rev. 11-94 Form Number 69-0636—1



Printed in U.S.A. on recycled paper containing at least 10% post-consumer paper fibers.