

**SAMSUNG**

*VEGA 290w*  
*EVOCA 90w Neo*



**ENGLISH/中文說明書**

## NOTE/注意事項

---

- **En** • This camera will not function without a battery.
- Use one 3V lithium battery(CR-123A or DL-123A).
- The lens cap automatically opens when the Power button is turned on.
- Do not open the lens cap with your fingers.

### **The shutter does not operate in the following circumstances:**

- When the camera has no battery or when the battery is almost drained.
  - When the Power is turned off.(When the lens cap is closed.)
  - When the zoom button is operating or when the film is winding or rewinding.  
(Rewinding will stop when the power button is pressed during rewinding.)
  - When the film remains in the camera after rewinding.
  - When the flash is being charged.
- ※ This camera is controlled electronically by a built-in microcomputer. Although unlikely, it may fail to operate under certain circumstances in which there is a strong electromagnetic field (near a TV, microwave etc.). If this occurs, please remove the lithium battery and replace after 2~3 minutes.

- 
- 中
- 像機沒裝電池就無法動作。
  - 使用一個3V鋰電池(CR-123A 或 DL-123A)
  - 電源開關一打開，鏡頭蓋就會自動打開。
  - 請勿用手指將鏡頭蓋打開。

#### 在下列情況下快門無法動作

- 像機沒裝電池或電池的電力已耗盡時。
- 電源關閉時。(鏡頭蓋關上時)
- 變焦 $\sim$ 正在操作中或底片正在進片或退片中。  
(回卷 中按 源便可停止回卷.)
- 退片完成後未將底片取出時。
- 閃光燈正在充電時。

※ 此像機由一個內藏微型計算機控制。在某些具有強電磁場的環境中( 近電視機，微波爐等) 可能會不工作，但可能性極小。如果出現這種情況，請取出鋰電池，2~3分鐘後再重新放回。

# CONTENTS/目

**En** Thank you for purchasing the SAMSUNG camera. Please read this manual before using your camera..

## TABLE OF CONTENTS

### PREPARATION

· Part names .....	6
· LCD panel .....	9
· Viewfinder and Indicators .....	11
· Attaching the strap .....	11
· Loading the battery .....	13
· Checking the battery .....	15
· Loading the film .....	16
· Using the camera.....	18
· Holding the camera .....	19
· Taking pictures .....	20
· Adjusting the diopter .....	22
· Buzzer operation .....	23

### TAKING PHOTOS

· Rewinding the film .....	25
· Date and caption (Q.D. model only) .....	27
· Using the flash mode .....	30
· Using the shooting mode .....	31
· Using the self mode .....	32
· Auto red-eye reduction .....	33
· Auto flash .....	34
· Fill-in flash .....	36

· Fill-in flash and red-eye reduction .....	37
· Flash off .....	38
· Spot shooting .....	39
· Continuous shooting .....	40
· Landscape shooting .....	41
· Bulb shooting (B Shutter) .....	42
· Snap shooting .....	43
· Step zoom .....	44
· Portrait zoom .....	45
· Using the focus lock .....	46
· Self-timer .....	48
· Double self-timer .....	49
· 2 second delayed shutter release .....	50
· Remote control shooting(Optional) .....	51
· Replacing the battery of the remote control(Optional) .....	52
· Panorama photography .....	53

### IMPORTANT NOTES

· Care and storage .....	54
· Trouble shooting .....	56

### SPECIFICATIONS

· Checking the camera .....	61
-----------------------------	----

中 非常感謝！選購三星像機。使用像機前請閱讀本手冊。

## 目

### 準備

· 各部名稱 .....	6
· LCD 液晶板 .....	9
· 觀窗及指示燈 .....	11
· 上背帶 .....	11
· 安裝電池 .....	13
· 檢查電池電力 .....	15
· 安裝底片 .....	16
· 使用像機 .....	18
· 持穩像機 .....	19
· 拍照 .....	21
· 調整視野 .....	22
· 蜂音器操作 .....	24

### 攝影

· 退片 .....	25
· 日期及留言(僅限Q.D.式) .....	27
· 閃光燈模式 .....	30
· 拍攝模式 .....	31
· 自拍模式 .....	32
· 自動消除紅眼 .....	33
· 自動閃光 .....	35
· 閃光燈強迫補光 .....	36

· 閃光燈強迫補光及消除紅眼 .....	37
· 不用閃光燈 .....	38
· 選點拍攝模式 .....	39
· 連納拍攝模式 .....	40
· 遠景模式 .....	41
· B快門 .....	42
· 快拍模式 .....	43
· 臺階式變焦模式 .....	44
· 自動取景模式 .....	45
· 使用焦距鎖定 .....	47
· 自拍器 .....	48
· 兩次自拍 .....	49
· 兩秒鐘延遲拍攝 .....	50
· 遙控拍攝模式(可選) .....	51
· 更換遙控器電池(可選) .....	52
· 全景攝影 .....	53

### 重要注意事項

· 保養與保存 .....	55
· 故障排除 .....	56

### 技術規格

· 檢查照相機 .....	62
---------------	----

## PART NAMES / 各部名稱

· Front / Top · 前面/頂部

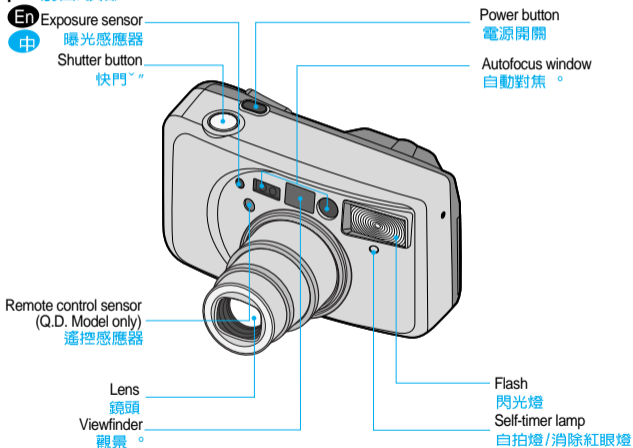

· Rear / Bottom · 後面/底部

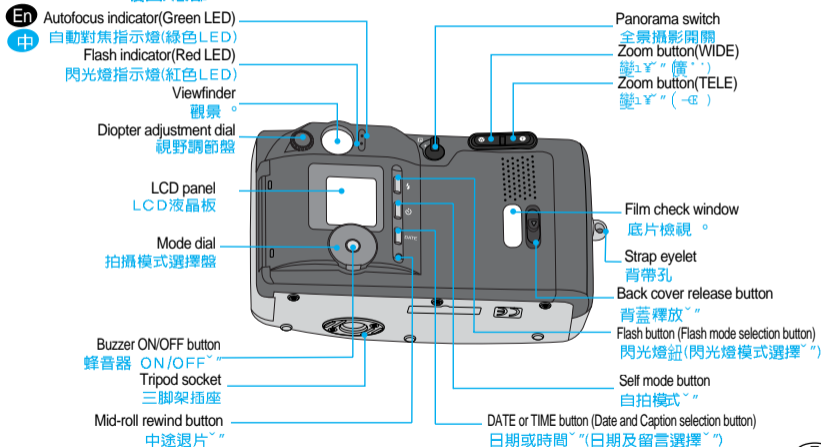

· Interior · 内部

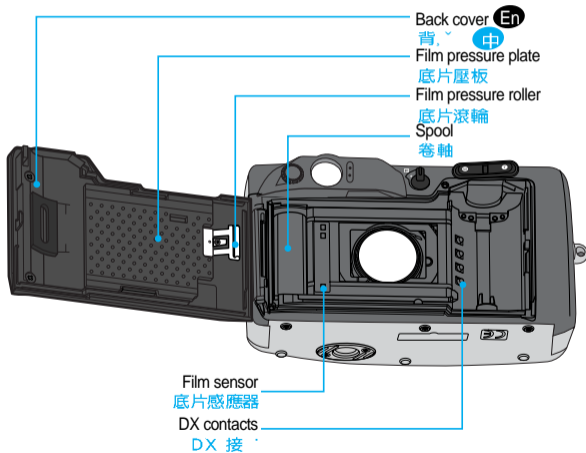



# LCD PANEL / LCD 液晶板

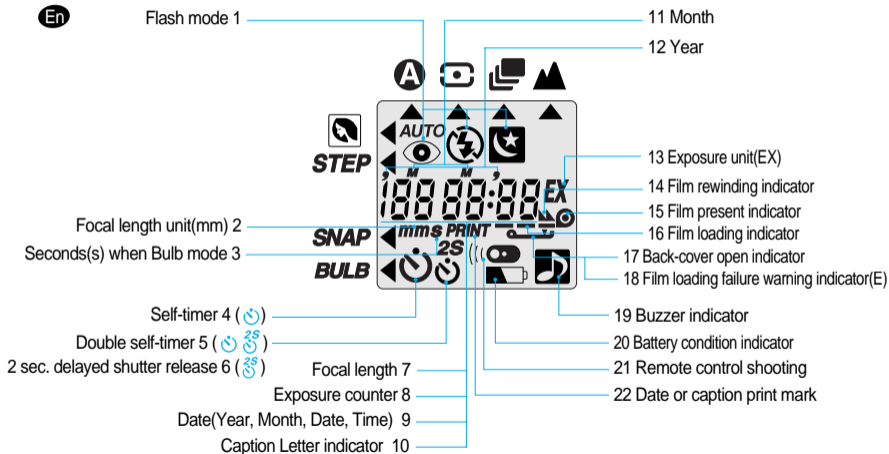

1	閃光燈模式	12	年
2	焦距單位(m m)	13	曝光值(EX)
3	B快門計算時間(秒)	14	底片退片指示
4	自拍器	15	底片現況指示
5	兩次自拍	16	底片安裝指示
6	兩秒/延遲拍攝	17	背蓋打開指示
7	焦距	18	底片錯裝警告指示(E)
8	曝光張數計數	19	蜂音器指示燈
9	日期(年,月,日,時間)	20	電池電力指示
10	留言字母指示燈	21	遙控拍攝模式
11	月	22	日期或留言印制標志

# VIEWFINDER AND INDICATORS / 觀窗及指示燈

## Viewfinder

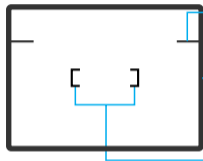

- En** Close range picture area mark  
- WIDE : Optimum picture area when shoot within 0.6m~1.5 m  
- TELE : Optimum picture area when shoot within 0.7m ~ 2m

**中** 微距取景

WIDE : 拍攝範圍在 0.6m ~ 1.5m 以內便可拍攝當 照片。

TELE : 拍攝範圍在 0.7m ~ 2m 以內便可拍攝當 照片。

Picture area frame

- WIDE : Optimum picture area when shoot over 1.5 m

- TELE : Optimum picture area when shoot over 2m

取景 1

WIDE : 拍攝範圍在 1.5m 以外便可拍攝當 照片。

TELE : 拍攝範圍在 2m 以外便可拍攝當 照片。

Autofocus frame (Focus on the subject with this frame)

自動對焦 1(用此 1在主體上對焦)

## ATTACHING THE STRAP / 1上背帶

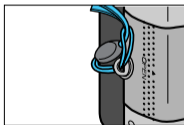
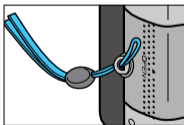

**En** · Refer to the illustrations above.

**中** · 參閱上圖。

## Indicators/ 指示燈

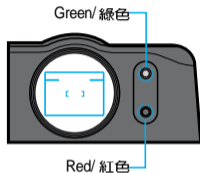

- En** 1. Autofocus Indicator (Green LED)
- When illuminated this confirms that conditions are suitable for picture taking.
  - When the subject is too close, (within 0.6m (1.97ft), the LED will blink rapidly and the shutter will lock. (Refer to page 23 for information of buzzer operation)
2. Flash Indicator (Red LED)
- Illuminates when the flash is fully charged. (In low light conditions)
  - Blinks rapidly when the flash is being charged. (Shutter will be locked)
  - It blinks quickly if you are out of the range.
  - Blinks slowly to indicate that the camera requires steady support (preferably a tripod) to avoid camera shake.

**中**

1. 自動對焦指示燈(綠色LED)
- 綠燈亮時(可以拍照)
  - 主體太近時(0.6m (1.97ft)以內), LED 會快速閃 并且快門會鎖定(參閱 24頁蜂音器操作知識)
2. 閃光燈指示燈(紅色LED)
- 閃光燈完全充足電時, 紅色燈會亮。(在光線弱暗時)
  - 閃光燈正在充電時, 紅色燈會快速閃。(快門會鎖定)
  - '∅'是閃光燈在迅速地一閃一閃的話, 這可能距離太遠而發生的。
  - 紅色燈慢速閃 表明橡機需要穩固支撐(最好是三腳架)以免受到震動。

## LOADING THE BATTERY / 安裝電池

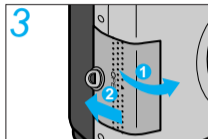
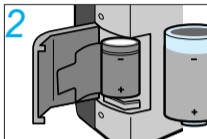
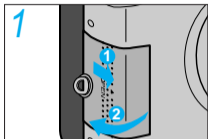

- En**
1. Open the chamber cover by sliding the battery chamber cover.
  2. Insert a new battery and ensure it is placed in the correct position.
  3. Close the chamber cover.

- 中**
1. 輕推電池室蓋，將其打開。
  2. 裝入新電池并確認電池已正確放置。
  3. 關上電池室蓋。

---

## En NOTE

- Use one CR-123A or DL-123A battery.
- The camera will automatically turn the power off when not used after 3 minutes.  
Remove the battery from the camera when the camera is not used for an extended period.
- Be sure to check the date and shooting mode when you load a new battery.
- If the date or time is incorrect, please refer to page 27 and adjust accordingly.



## 中 注意事項

- 使用一個CR-123A 或 DL-123A 電池。
- 像機不用後三分鐘，像機會自動關上鏡頭蓋并切斷電源。  
如果長時間不使用像機，請將電池取出。
- 電池更換後，請務必檢查一下日期及拍攝模式。
- 如果日期或時間不正確，請參閱第(27)頁，并根据情況進行調整。

# CHECKING THE BATTERY / 檢查電池電力

**En** · You can check the battery life on the LCD panel.

**中** · 從液晶板上就能檢查電池電力。

	<b>En</b>	<b>中</b>
	1. Normal operation - The battery condition indicator does not appear.	1. 正常狀態 - 不出現電池電力指示。
	2. The indicator appears half way. - The battery life is low and you should ensure that a replacement battery is available.	2. 指示一半的電池電力。 - 電池電力已降低，應確保有備用電池。
	3. The indicator blinks. - The battery is exhausted. Load a new battery.	3. 電池電力指示閃爍。 - 電池電力已耗盡，需更換新電池。

## **En** NOTE

- Do not remove the battery while the camera is operating, because it may cause the camera to malfunction.
- Battery performance is reduced in low temperatures (under  $-10^{\circ}\text{C}$  ( $14^{\circ}\text{F}$ )); Try to keep the camera warm between shots. (The battery will operate normally again when the temperature returns to normal).
- Please dispose of the exhausted battery with care.
- Some local authorities may require batteries to be disposed of separately from other refuse.

## **中** 注意事項

- 像機使用中，請勿將電池取出以免干擾像機的功能。
- 低溫時電池的性能會下降 [ $-10^{\circ}\text{C}$  ( $14^{\circ}\text{F}$ ) 以下]。拍照間隔期間要注意像機的保暖。(溫度恢復正常時電池又會正常工作。)
- 廢舊電池請勿隨意處理。
- 有些地方管理部門會要求將電池與其他垃圾，分裝處理。



## LOADING THE FILM / 安裝底片

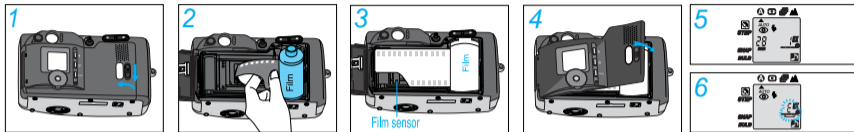

- En**
1. Open the back cover by sliding the release knob as shown above.
  2. Insert a roll of film in the chamber. Do not force the film into position.
  3. The film should lie flat.
  4. Close the back cover. It will close with a “click”.
  5. The film will automatically advance until the film counter reads “1”.
  6. If a film is loaded incorrectly, the LCD panel will display an “E” warning signal. (Refer to page 23 for information of buzzer operation) Reload the film following the steps shown above.

### NOTE

- The camera automatically adjusts for ISO 50-3200 DX film.
- When you use non-DX film, the camera will set the film speed at ISO 100.
- Load the film in subdued lighting.



中

1. 如上圖所示，輕推背蓋釋放栓打開背蓋。
2. 裝進一卷底片。不要將底片強行壓入。
3. 底片應平展放置。
4. 關上背蓋。關好時會聽到“喀”的一聲。
5. 底片會自動進片，直到底片計數器顯示“1”。
6. 若底片安裝不正確，液晶板會顯示警告信號“E”。(參閱24 頁蜂音器操作知識)  
按照上述步驟重新安裝底片。

### 注意事項

- 該像機自動設置ISO 50-3200有DX 的底片。
- 使用无DX 的底片時，像機會自動設定在 ISO 100 度。
- 在弱光下安裝底片。

## USING THE CAMERA / 使用像機

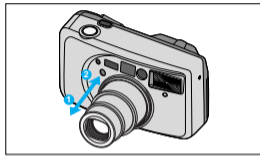
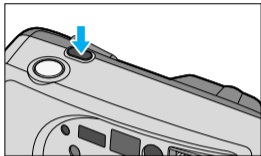

- En**
- Press the Power button to turn the power on. The indicators will appear on the LCD panel.
  - If the camera is not used for 3 minutes, the power will be turned off automatically.
  - While looking through the viewfinder, aim the camera at the subject and operate the zoom buttons.
  - Press the “**T**” (Tele) button to move the lens out ① and press the “**W**” (Wide) button to move the lens in ②.
  - During this operation, the LCD panel shows the focal lengths in the following sequence : 28, 35, 40, 45, 50, 55, 60, 65, 70, 75, 80, 85, 90 mm.
- 中**
- 下電源開關打開電源。液晶板上會出現指示。
  - 若三分鐘不使用像機，像機會自動切斷電源。
  - 從觀景窗對准拍攝目標，并調整伸縮鏡頭。
  - 按“**T**”（望遠）“則鏡頭伸長①（按“**W**”（廣角）“則鏡頭縮回②）。
  - 在此操作過程中，在液晶板上顯示的焦距順序為：28, 35, 40, 45, 50, 55, 60, 65, 70, 75, 80, 85, 90 mm。

## HOLDING THE CAMERA / 持穩像機



En

- ※ In order to avoid camera shake, hold the camera steady, especially when using longer focal lengths (Tele).
- Place the camera strap over your wrist.
- Both elbows (horizontal picture) or one elbow (vertical picture) should be held close to your body.
- Keep your eye close to the viewfinder when using the camera. This ensures correct framing. Ensure you can see all four sides of the viewing frame when composing your shot.

### NOTE

- Avoid obstructing the lens when you take a picture. Pictures can be spoiled when a finger, hair or camera strap falls in front of the Lens, Exposure Sensor or Auto-focus Windows.
- When you take vertical pictures with flash, the flash should be above the lens.

中

- ※ 為避免像機震動，請持穩像機，尤其在使用長焦距（望遠）時要特別注意。
- 用手腕握住像機的背帶。
- 將雙（水平拍照）或單（垂直拍照）肘近身體。
- 拍照時眼睛要近觀取景窗。這樣可保證取景正確。
- 拍照時要確定能看到取景窗的四周。

### 注意事項

- 拍照時要避免擋住鏡頭。若手指，頭髮或像機背帶等遮住鏡頭，曝光感應器或自動對焦窗，會影響照片的品質。
- 使用閃光燈拍垂直照片時，閃光燈要位於鏡頭的上方。

## TAKING PICTURES / 拍照

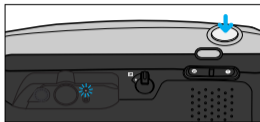

- En** Aim the Autofocus frame at a subject. (Refer to page 12)
- Press the Shutter button half way down. The lens is focused when the green lamp turns on.
  - Press the Shutter button all the way down to take a picture.
  - The film will automatically advance after shooting and the frame counter will advance.
  - Exposure range (WIDE) : 0.6m ~ ∞, (TELE) : 0.7m ~ ∞

### NOTE

- When the flash is being charged, the flash indicator ( **AUTO** ⚡ ) on the LCD panel blinks and the shutter will not operate.
- When the Red LED blinks slowly, use a tripod or support the camera to avoid camera shake.
- In order to avoid camera shake, hold the camera steadily and press the Shutter button gently, particularly when using longer focal lengths. (Tele)
- After taking pictures, turn off the camera. This will protect the lens and prevent unintended shots. (If not used for 3 minutes, the camera will turn off automatically).
- Should a subject be closer than 0.6m, the LED will blink rapidly to indicate that the subject is too close and the shutter will lock.
- Under certain circumstances, the autofocus system will be over-ridden. The camera will then function, even though the subject is too close. Some examples of this are :
  - A low contrast and bright subject.
  - Strong light directed towards the camera.
  - The subject is closer than 0.3m

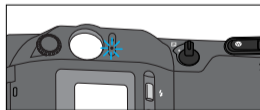
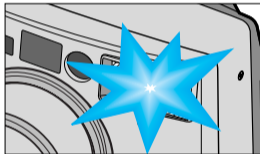

- 中** 將自動對焦 對準 主體。(參閱第12頁)
- 半按快門。綠色燈亮時，鏡頭聚焦。
  - 完全按下快門拍照。
  - 底片會自動進片并且底片計數器的計數會遞增。
  - 拍攝範圍(廣角):0.6公尺至 $\infty$  ,(TELE):0.7公尺至 $\infty$ 。

### 注意事項

- 閃光燈正在充電時，液晶板上的閃光燈指示(AUTO)閃 并且快門不動作。
  - 紅色 LED 慢速閃 時，需使用三角架或持穩相機，以免受到震動。
  - 爲了避免像機受到震動，請持穩像機并輕按快門，特別是在使用長焦距時。(望遠)
  - 拍完照后，請關上像機。這樣做可以保護鏡頭并防止快門意外啓動。(若三分鐘不使用，像機會自動關閉)
  - 若目 近于0.6m，LED快速 以指示拍 目 于近 快 被定。
  - 在一定 境下，自 焦系 无效。使目 于近，相机也 工作。
- 例如：
- 低 比度及亮度目 物
  - 强光 照相机
  - 目 物距 在0.3m以 以

## ADJUSTING THE DIOPTER / 調整視野

---



- En · Select the maximum zoom setting and turn the diopter adjustment dial until the viewfinder display becomes clear.
- 中 · 選擇最大變焦設置并旋轉視野調節盤，直到觀景窗內的畫面清晰為止。

# BUZZER OPERATION



- En · The buzzer function can be selected by Buzzer ON/OFF button and it will operate only if the buzzer mark appears on the LCD panel.

- According to the function, the buzzer sound is as follows.

Buzzer sound	Function	Application
1 short beep	Selection	When you press Flash, Self, Buzzer button When Mode Dial is changed
3 beeps	Warning	When hand shake is detected
3 short beeps	Warning/Error	When AF Lock (shorter than minimum shooting range) occurs When a film is loaded incorrectly When you press Tele/Wide button in the SNAP mode In case of shooting beyond the scope of flash range. (Refer to page 30. The function of Auto Flash zoom compensation)
5 long beeps	Completion	When the rewinding is completely finished

## 蜂音器操作



中 · 按 BUZZER ON/OFF 〰 可選擇蜂音器機能，且蜂音器標誌如出現在 LCD 液晶板上便將工作。

· 根據功能，蜂音器聲音如下。

蜂音器聲	功能	應用
1 個短	選擇	按閃光燈，自拍，蜂音器 〰 時，更改 Mode Dial 時，
3 個短信號	警告	察覺手動時，
3 個短信號	警告 / 錯誤	出現 AF 鎖定時(比最小拍攝範圍還近) 不正確地安裝底片時 在 SNAP 模式中按下 Tele/Wide 〰 時， 要想照閃光燈範圍以外的物體 (參閱 30. 自動閃光燈補正機能)
5 個長信號	完成	退片結束時



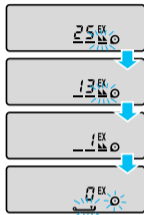

# REWINDING THE FILM / 退片



## En 1. Automatic rewinding

- After taking all the pictures on a roll of film, the camera will automatically rewind the film. The motor stops when the rewinding is completed.
- When the rewinding is completed, the icon (  ) will blink. You may remove the film at this point. (Refer to page 23 for information of buzzer operation)

## 中 1. 自動退片

- 拍完一卷底片后， 會自動退片。退片完成后，馬達會停止轉動。
- 完成回卷<sup>aæ</sup> 示 (  ) 。此<sup>a`~</sup>...可取下。∅  
(參閱 24頁蜂音器操作知識)

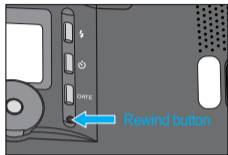

## En 2. Mid-roll rewinding

- To rewind the film in the middle of a roll, press the Mid-roll rewind button. The film will be completely rewound, ready for processing. You will not be able to reload the film.

### NOTE

- If you press the Power button during film rewinding, the rewinding is interrupted until the Power button is released.
- If the motor stops before the LCD shows "0", replace the battery. Do not open the back cover until the battery is replaced.

## 中 2. 中途退片

- 按中途退片<sup>∨</sup>就可中途退片。底片會完全回卷，以備衝洗。已退出的底片不能再裝回。

### 注意事項

- 若回卷。卷中按Power按<sup>∨</sup>，回卷操作 停止，`至Power按<sup>∨</sup>被放。`
- 若馬達在液晶板顯示“0”之前即停止，應更換電池。電池未更換前請勿打開背，<sup>∨</sup>。

# DATE AND CAPTION (Q.D.MODEL ONLY) / 日期及留言 (僅限Q.D.式)



**En** • Use the DATE button to control "Date" and "Caption"

**中** • 使用 DATE 〰 控制“日期”及“留言”。

## **En** 1. Changing "Date" format or selecting the caption

- Press the DATE button to select one of the different formats.(Refer to the left sequences)
- The "PRINT" mark on the LCD panel will blink during the print.

## **中** 1. 更改“日期”格式或選擇留言

- 按 DATE 〰 選擇不同的格式。(參閱左側順序)
- 印制時，液晶板上的“PRINT”標誌會閃。

## 2. Date Zone / 日期區域



<Normal picture / 正常攝影>



<Panorama shot / 全景攝影>

## NOTE / 注意事項

**En** • Under certain circumstances, the date will not print on the final frame of a film.  
• Printing date and time does not function in NON Q.D MODEL (TIME is printed beside the DATE or TIME button on the back cover), but you can check date and time through the LCD panel.

**中** • 在某些情況下，最 > 一張底片拍出來的照片無法印制日期。  
• 日期時間印記不能適用於 NON Q.D MODEL (時間印於後面日期活時間按鈕旁)，不過你可透過 LCD 螢幕檢驗日期時間。

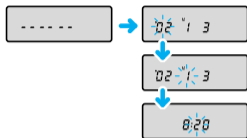

### En 3. Changing the date setting

- To change the date or time, press and hold down the DATE button for 2 seconds. The first sector of the date format will blink.
- To select the sector that you want to change, press the DATE button.
- Change the date setting by operating Zoom buttons. TELE button to increase, WIDE button to decrease.

#### NOTE

- This camera will set the date automatically until 2099.
- A year mark will be indicated by the last 2 digits on the LCD panel. It will be indicated by 4 digits on the picture.
- Under these circumstances the camera will operate as normal.

#### Example

2002 → "02"  
2010 → "10"

### 中 3. 更改日期設置

- 更改日期或時間，按下 DATE 鍵並保持兩秒鐘。日期格式的第一部分將閃爍。
- 按 DATE 鍵選擇要更改的部分。
- 按變焦鍵更改日期設置。用 TELE 鍵增大，WIDE 鍵減小。

#### 注意事項

- 2098年之前相機機會自動設定日期。
- 年標志由 LCD 液晶板上的最後兩位數字指示，會在照片上顯示4位數字。
- 在這些情況下，相機機會正常工作。

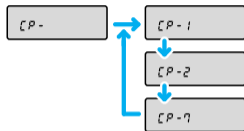

## MESSAGE CAPTIONS / 留言

CP-1	I LOVE YOU!
CP-2	A HAPPY BIRTHDAY
CP-3	THANK YOU
CP-4	CONGRATULATIONS
CP-5	A HAPPY NEW YEAR
CP-6	MERRY X-MAS
CP-7	HELLO!

### En 4. Selecting the caption print

- When the LCD panel shows "CP-1"(refer to the previous picture ), you can select one of seven captions as follows :
- To change the captions, operate the zoom buttons.("T" or "W")
- When caption Mode is selected, message caption will appear on the LCD panel in order.

#### NOTE

- The camera will print either a date or a caption. You cannot select both date and caption on the same picture. (The caption is printed on the date zone).
- Remember to reset the date and time after changing the battery.

### 中 4. 選擇留言印制

- 液晶板顯示“CP-1”時(參閱前面的示圖), 可選擇下列七種不同留言中的一種:
- 按變焦“更改留言.” (“T” 或 “W”)
- 選擇留言模式時, 由使用者更改 “加入字母” 模式, 留言便會依次出現在LCD 液晶板上。

#### 注意事項

- 像 f 只能印制日期或留言, 不能在同一個照片上同時印制日期和留言。(留言印制在日期區域上)。
- 切記更換電池後重新設置日期和時間。

# USING THE FLASH MODE / 閃光燈模式

**En** · You can select the flash mode by pressing the FLASH button.

**中** · 按閃光燈鈕選擇閃光燈模式。

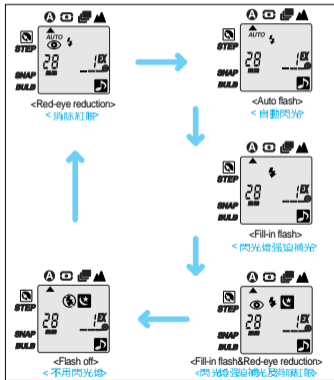

## NOTE / 注意事項

**En** · In case of the "Auto Flash" function, the camera will retain the mode even though the camera is turned off. When you turn on the camera, check the LCD panel.

### ※ THE FUNCTION OF AUTO FLASH ZOOM COMPENSATION

The zoom mode can be changed from TELE to WIDE when the shot mode is on normal shot mode A or on SPOT shot mode under the condition of flash radiation. (Red-eye reduction, Auto Flash, Fill-in Flash) The zoom operates automatically to prevent the pictures from getting too dark.

**中** · 使用“自動閃光”功能后，即使相機電源關閉，相機將仍然會保留該模式。打開相機時，請檢查液晶板。

### ※ 自動閃光燈補正機能

在閃光燈的補光條件下(消除紅眼,自動補光,閃光燈強迫補光模式),攝影模式時一般攝影模式A或者SPOT攝影模式的情況下,放大鏡頭的位置有時由Tele轉換為Wide.為了防止照片太暗,放大鏡頭會自動的動作。

## USING THE SHOOTING MODE / 拍攝模式

**En** · You can select the shooting mode by turning the dial clockwise or counter-clockwise.

**中** · 您可 或逆 方向 以 拍 模式。

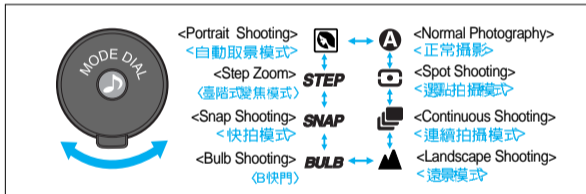

# USING THE SELF MODE / 自拍模式

**En** · You can select the self mode by pressing the Self mode button.

**中** · 按 SELF 選擇自拍模式。

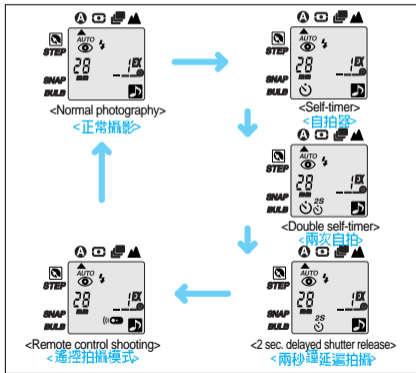

## NOTE / 注意事項

- En** · With the "Non Q.D. model", the "Remote control shooting" indicator does not appear on the LCD panel.
- After using the "2 sec. Delayed Shutter Release" or "Remote Control Shooting" modes, the camera will remain in that mode, until a new selection is made.
- 中** · 對於"非 Q.D. 式", 遙控拍攝"模式不在液晶板上出現。
- 使用"兩秒鐘延遲拍攝"或"遙控拍攝"模式后, 像機仍然停留在該模式中, 直到選擇新模式為止。



# AUTO AUTO RED-EYE REDUCTION / 自動消除紅眼

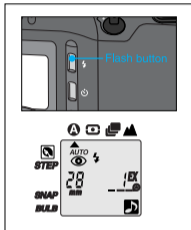

- En**
- In low light conditions, the flash will automatically fire to obtain a suitable exposure.
  - You can decrease the red-eye phenomenon automatically when taking a portrait picture in low light.

## NOTE

- The red-eye reduction mode dramatically reduce the possible red-eye effect by emitting rapid pre-flash to shrink the subject's pupils before the main flash fires. Do not allow the subject to move until the main flash has fired.
- Shooting beyond the scope of the flash range will induce the activation of the buzzer and the zoom lens. (applied to the cases of normal shot mode A, SPOT shot mode)

- 中**
- 在光線弱暗時，閃光燈會自動閃光，以獲得合適的曝光。
  - 可自動減輕在光線弱暗時拍照人像所出現的紅眼現象。

## 注意事項

- 閃光燈閃光之前，切勿使主體移動。
- 照了閃光燈範圍以外的物體，有了聲音，同時放大鏡頭會起作用。一般攝影模式A，SPOT攝影模式的情況下可以適用。



<Auto flash>  
<自動閃光>



<With auto red-eye reduction>  
<以自 消除紅眼>

## AUTO ⚡ AUTO FLASH

---

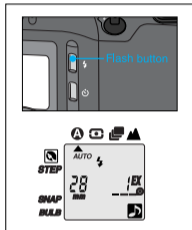

- En**
- Select the Auto flash Mode by pressing the FLASH button 1 time.
  - Auto flash mode activates the flash by measuring the brightness of the object.
  - Flash will not engage when the shooting object is too bright.

### NOTE

- Once the Auto Flash Mode is selected, it will remain active even when camera is turned off. (but)When you change the battery, the mode will be set to auto red-eye reduction.
- Shooting beyond the scope of the flash range will induce the activation of the buzzer and the zoom lens.

## AUTO ⚡ 自動閃光

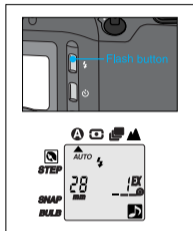

- 中 · 按FLASH按~"一次以 自 模式。
- 自動閃光模式測定了物體的明暗之後，閃光燈開始作用。
- 要是物體太明亮，閃光燈可能不會作用。

### 注意事項

- 自動閃光模式被選擇了之後，關掉電源了也可以繼續作用。  
不 f ~..更 † 池^`，模式被 定@ 自 消除β1眼。
- 照了閃光燈範圍以外的物體，有了聲音，同時放大鏡頭會起作用。

## ⚡ FILL-IN FLASH / 閃光燈強迫補光

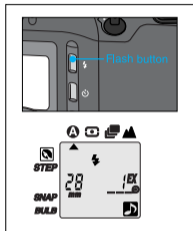

- En** · Select this mode by pressing the FLASH button twice.
- When the main subject is in shadow and the surrounding light conditions are too strong for the auto-flash to engage, the fill-in flash allows you to expose the subject correctly.

### NOTE

- When using this mode, the flash fires regardless of the brightness of the subject and background.
- Shooting beyond the scope of the flash range will induce the activation of the buzzer and the zoom lens. (applied to the cases of normal shot mode A, SPOT shot mode)

- 中** · 按FLASH按“ ” 次以 模式。
- 當主體在暗處而環境光線太亮，以至於自動閃光不起作用時，使用閃光燈強迫補光來平衡主體的曝光。

### 注意事項

- 使用閃光燈強迫補光時，不管主體及背景的光線是否充足，閃光燈都會閃光。
- 照了閃光燈範圍以外的物體，有了聲音，同時放大鏡頭會起作用。一般攝影模式A，SPOT攝影模式的情況下可以適用。





## FILL-IN FLASH AND RED-EYE REDUCTION/ 閃光燈強迫補光及消除紅眼

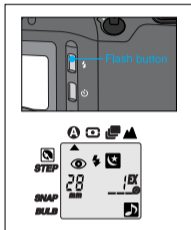

- En · Select this mode by pressing the FLASH button 3 times.
- Use this mode when you take a picture of a person in low light condition.

### NOTE

- Use a tripod to avoid camera shake.

- 中 · 按FLASH按~三次以 模式。
- 在光線弱暗時拍照人像，使用此模式。

### 注意事項

- 使用三腳架以避免像機受到震動。



## FLASH OFF / 不用閃光燈

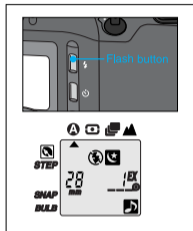

- En · Select this mode by pressing the FLASH button 4 times.
- Use this mode when you want to take pictures without flash.

### NOTE

- When using the Flash Off function, you may need to use a tripod to avoid camera shake.

- 中 · 按FLASH按~四次以  模式。
- 希望不用閃光燈拍攝照片時使用此模式。

### 注意事項

- 使用不用閃光燈功能時，可能需要使用三腳架以避免像機受到震動。

## SPOT SHOOTING / 選點拍攝模式

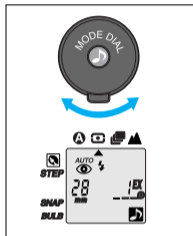

- En**
- Use this mode when photographing a specific subject in a situation where the camera may have difficulty in focusing.
  - Certain subjects, such as a person in a crowd, can be difficult to photograph.
  - This mode enables you to have your specific subject clear, even when surrounded by other subjects in the picture.
  - Select SPOT mode by turning "Mode Dial".
  - The camera focuses on the subject in the spot shooting focus frame.

### NOTE

- Shooting beyond the scope of the flash range will induce the activation of the buzzer and the zoom lens. (Applicable in Red-Eye Reduction, Fill-in Flash, and Auto Flash.)
- 中**
- 在像 比較難對焦的情況下拍攝一個特定主體時，使用此模式。
  - 某些主體，例如人群之中的一個人，可能難被拍攝。
  - 即使在照片中特定主體被包圍在其中央主體之中，此模式能使特定主體變得清晰。
  - 旋轉 "Mode Dial" 選擇 SPOT 模式。
  - 像 在選點拍攝對焦系內的主體上聚焦。

### 注意事項

- 照了閃光燈範圍以外的物體，(有了聲音，同時放大鏡頭會起作用。)消除紅眼，閃光燈強迫補光，自動補光功能可以適用.)



## CONTINUOUS SHOOTING / 連續拍攝模式

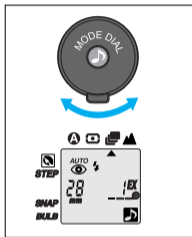

- En**
- Select this mode by turning "Mode Dial".
  - Use this mode to take a sequence of pictures.
  - As long as you press the shutter button, the camera will continue to take pictures.

### NOTE

- If flash is required, the time between shots will be increased due to the flash recycling.
- The flash does not fire if no film is loaded (except for "Fill-in Flash" mode).

- 中**
- 將 Mode 旋鈕 轉 到 連續 拍攝 模式。
  - 使用此模式可拍攝一系列照片。
  - 只要按住快門鈕，像機會連續拍照。

### 注意事項

- 如果需要閃光燈，由於閃光燈回電，兩次拍攝的間歇時間會延長。
- 如果沒裝底片，閃光燈不會亮（閃光燈強迫補光模式除外）。





## ▲ LANDSCAPE SHOOTING / 遠景模式

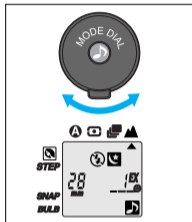

- En** · If you can't shoot clearly distant subjects through a window, use this mode by turning Mode Dial to LANDSCAPE mode.

### NOTE

- With this mode, the flash does not fire.
- Use a tripod to avoid camera shake in low light conditions.
- When LANDSCAPE mode is not in use change this mode into normal mode.

- 中** · 若不能透過窗戶拍攝遠處的景物，可將 Mode 旋鈕調至 LANDSCAPE。

### 注意事項

- 使用此模式時，閃光燈不閃光。
- 在光線弱暗時，使用三腳架以免影像受到震動。
- 不能使用 LANDSCAPE 模式時，請將此模式調到標準模式。



<Without Landscape mode>

<不用遠景模式>



<With Landscape mode>

<用遠景模式>

# BULB BULB SHOOTING(B SHUTTER)/B快門

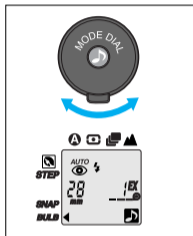

- En · To shoot subjects that require an extended shutter speed shooting such as Portrait in fireworks and night scenes, Select this mode by turning mode dial.
- The shutter remains open as long as the shutter button is depressed. The time selected is shown on the LCD panel and the maximum time is 60 seconds.

## NOTE

- Use this mode only in low light.
- To avoid camera shake, use a tripod.
- To prevent of over-exposure from the high brightness, the Bulb shooting mode will not operate even though the mode is selected.

- 中 · 需求快速快 f 速度的拍 ， 如在焰火夜 的肖像拍 ， 可透 f fi Mode 旋 œ 模式。
- 只要按住快門 ”， 快門會一直開着。 可選的曝光時間顯示在液晶板上， 最長時間為60秒鐘。

## 注意事項

- 僅在弱暗光線下使用此模式。
- 為避免相機受震動， 請使用三腳架。
- 避免用高光度曝光。 儘管模式被選擇， 快門模式將不工作。

# SNAP SNAP SHOOTING / 快拍模式

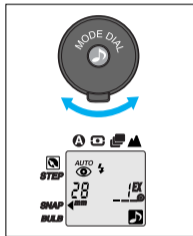

- En**
- Select SNAP mode by turning "Mode Dial".
  - Use this mode when taking a picture of active subjects such as children or pets. (They are difficult to focus on)
  - When you select this mode, the camera will set the wide position (28mm) and the focus is fixed.
  - If you depress the shutter button continuously, the camera will take a sequence of shots.

## NOTE

- The subject must be within the range 1.5m ~ 7m (4.9ft ~ 22.9ft).
- If you press the zoom(T/W) or power button while you operating this mode will be release to normal photography.

- 中**
- 旋轉 "Mode Dial" 選擇SNAP 模式。
  - 拍攝動態主體，如小孩或寵物時，使用此模式。（他們比較不容易對焦）
  - 使用此模式時，像 f 會設定在廣角位置( 28mm )，并且焦距固定。
  - 如果一直按着快門，相機會不斷拍攝。

## 注意事項

- 主體必須在 1.5m~7m(4.9~22.9ft)的範圍內。
- 若按變焦(T/W)或電源開關，可照出正常的照片。（工作這感模式）

# STEP STEP ZOOM/臺階式變焦模式

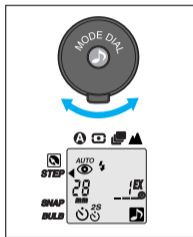

- En**
- Select this mode by turning "Mode Dial".
  - Use this mode to take a number of pictures of the same subject using different focal lengths.
  - The number of photos (up to 3) depends on the focal length chosen. (Refer to chart below)
  - You can choose the focal length by operating the zoom buttons. ("T" or "W")

## NOTE

- The first shot is taken after 10 seconds.
- From the second shot, the interval between shots is 2 seconds.
- If flash is required, the time between shots will be increased due to the flash recycling.



- STEP 變焦模式可拍攝同一個主題，但使用不同的焦距。
- 拍攝的照片數量（最多可拍 3 張）取決於所選的焦距。（請參閱下表）
- 您可以透過操作變焦按鈕（"T" 或 "W"）來選擇焦距。

Number of Photo	90mm	85mm	80mm	75mm	70mm	65mm	60mm	55mm	50mm	45mm	40mm	35mm	28mm
3 EX	①							②					③
3 EX		①						②					③
3 EX			①					②					③
3 EX				①				②					③
3 EX					①			②					③
3 EX						①		②					③
3 EX							①	②					③
3 EX								①	②				③
3 EX									①	②			③
2 EX										①	②		
1 EX												①	

## 注意事項

- 拍攝第一張照片後，需等待 10 秒。
- 從第二張照片開始，每張照片之間的拍攝間隔為 2 秒。
- 若需要閃光燈，拍攝間隔會因閃光燈充電而增加。



## PORTRAIT ZOOM/自動取景模式

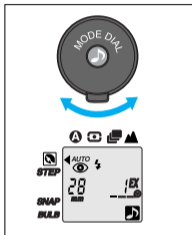

- En** . Select this mode by turning "Mode Dial".
  - . Use this mode to maintain a constant subject size within the frame, even though the distance to a subject may vary.
  - . Position your subject in the centre of the viewfinder and press the shutter button half-way. The zoom will operate automatically to attain the optimum shot.
  - . Press the shutter button fully to take a picture.
- 中** . 將“模式選擇盤”轉，可選擇此模式。
- . 使用此模式，不管像機離主體距離的遠近，可保持照片中的主體大小不變。
  - . 將主體對準在觀景窗的中央，半按快門。變焦鏡頭會自動調節以獲得最佳拍攝。
  - . 完全按下快門拍照。



<Normal mode>  
<正常模式>



<Portrait zoom>  
<自動取景模式>

## USING THE FOCUS LOCK / 使用焦距鎖定



**En** · If you want to focus on a subject that is not in the centre of your picture, use the Focus Lock function described below.

1. Aim the camera with the autofocus frame superimposed over the subject.
2. Press the shutter button half way down. (Green LED light)  
Be careful not to press the shutter button all the way down to avoid taking an unwanted picture.
3. Keeping the shutter button depressed, recompose your picture as desired.  
Hold the camera steadily and gently press the shutter button completely down.  
The Focus Lock can be released at any time by lifting your finger from the shutter button.

### ATTENTION

**The Autofocus system of this camera may not function in circumstances below :**

- The subject blends into the background.
- The subject is fast moving.
- The subject does not reflect enough light back into the autofocus receiver (e.g. very dark objects).
- The subject is very narrow, either horizontally or vertically (e.g. a lamppost).
- There is more than one subject, one near the camera and one some distance away.
- Strong light is directed at the camera. (the subject is back lit).
- Fireworks and smoke.
- Shining or glossy surfaces such as a car body or the surface of water.

In these circumstances, using the Focus Lock feature may help to solve the problem.



中 · 如果 $\sim$ 想要拍攝的主體不在照片的中央位置，請按下列方式使用 焦距鎖定功能。

1. 將  $f$  對準所要拍攝的主體，使其落在自動對焦系裏。
2. 半按快門 $\sim$ ”。(綠色LED亮)  
小心不要將快門 $\sim$ ”完全按到底，以免拍出不想要的照片。
3. 保持半按快門 $\sim$ ”的狀態，移動  $f$  至 $\sim$ 所要拍攝的畫面。  
持穩  $f$  并完全按下快門 $\sim$ ”。  
只要手指離開快門 $\sim$ ”，焦距鎖定就會解除。



### ⚠ 注意

相機的自動對焦系統在下列情況下不工作：

- 主體和背景渾然一體。
- 主體正在快速移動。
- 主體不能將足 $\sim$ 的光線反射回自動對焦接受器(例如，非常暗的物體)。
- 主體在垂直方向或水平方向非常窄，(例如，路燈柱)。
- 主體多於一個，一個  $f$  近  $f$  而其他較遠。
- 有體光對準  $f$ 。(主體逆光)。
- 煙火及煙霧。
- 會發光或光滑的表面，如汽車的車身或水的表面。  
在這些情況下，使用對焦鎖定特性可幫助解決問題。



## SELF-TIMER / 自拍器

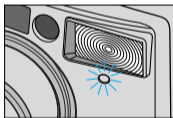
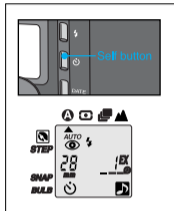

- En** · This can be selected by pressing the SELF button once. You can take a picture of yourself by using this mode.
- When pressing the shutter button, the self-timer lamp illuminate for 7 seconds. Then the lamp blinks rapidly for 3 seconds and the picture is taken.
- 中** · 按一次 SELF 按钮选择此模式。使用此模式可以替自己拍照。
- 按下快门按钮后自拍灯会慢速闪烁 7 秒钟。然后再快速闪烁 3 秒钟才拍照。







## DOUBLE SELF-TIMER / 兩次自拍

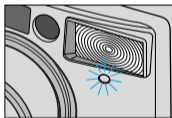
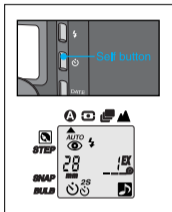

- En**
- You can select this mode by pressing the SELF button twice.
  - Press the shutter button and a shot will be taken in the same way a self timer shot is taken. A further shot will be made after 2 seconds.

### NOTE

- When using the flash, the shooting interval may increase due to the flash recharging time.

- 中**
- 按兩次 SELF 選擇此模式。
  - 按快門，照片會以單次自拍同樣的方式拍攝。另一次拍攝在 2 秒後進行。

### 注意事項

- 使用閃光燈時，由于閃光燈的充電時間，兩次拍攝的間歇時間會延長。





## 2 SEC. DELAYED SHUTTER RELEASE /

### 兩秒鐘延遲拍攝

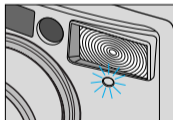
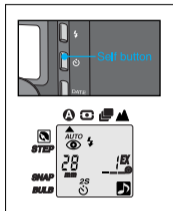

- En** · Use this mode to avoid camera shake caused by camera movement during hand held shots.
- In this mode, a picture is taken 2 seconds after releasing the shutter button.
- To use this mode, place the camera on a steady surface, select by pressing the Self mode button 3 times before taking the picture.
- 中** · 爲了避免手動按快門時震動像  $f$ ，可以使用此模式。
- 採用此模式，像  $f$  在快門釋放 2 秒後才拍照。
- 使用此模式時，將像  $f$  放在穩固的表面，在拍照前按三次 SELF 。

# REMOTE CONTROL SHOOTING (OPTIONAL)

## 遙控拍攝模式 (可選)

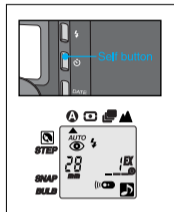

- En** · Select this mode by pressing the SELF button 4 times. (You can only use this function with the Q.D. model camera)
- When you select this mode, the self-timer lamp will blink every 2 seconds.
  - To take a picture using a remote control, press the Remote Control shooting button. The camera will take a picture after two seconds.
- 中** · 按四次 SELF 選擇此模式。(此功能僅限用于 QD 式像機)。
- 選擇此模式時，自拍燈每兩秒鐘會閃一次。
  - 使用遙控拍照時，請按遙控拍攝模式。

### Names of parts of the Remote Control / 遙控器各部名稱



## REPLACING THE BATTERY OF THE REMOTE CONTROL (OPTIONAL) / 更換遙控器電池(可選)

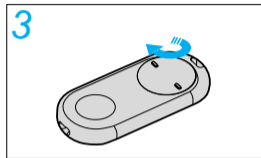
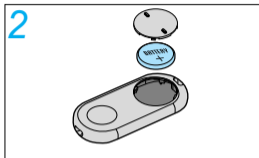
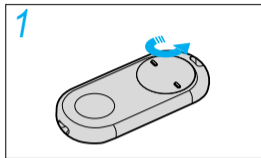

### En Replacing the battery

- Refer to the illustrations above.

### NOTE

- Use one lithium battery (JIS CR2025)
- Be sure to place a battery in the correct position. The positive contact (+) must be facing up.

### 中 更換電池。

- 參閱上圖。

### 注意事項

- 使用一個裏電池(JIS CR2025)
- 確認電池的位置正確。正極(+)朝上。

# PANORAMA PHOTOGRAPHY / 全景攝影

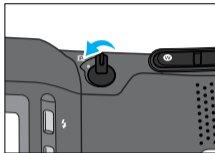

En

- Use this mode to capture a panoramic view.
- When you set this mode, the viewfinder will alter to indicate the panoramic scene.
- The picture area with this mode will be narrowed.
- Select this mode using the PANORAMA switch. The PANORAMA mode can be used on selected frames in a film.
- Remember to inform your processor that some shots are panoramic. There may be an extra charge for this service.

## NOTE

- The date can be imprinted with this mode.(Q.D. model only-Refer to page 27)

中

- 使用此模式取得全景畫面。
- 設置此模式時，觀景窗會相應變化以表示全景畫面。
- 使用此模式時，取景 1 會變窄。
- 使用 PANORAMA 開關選擇此模式。PANORAMA 模式可用于某些所選的畫面。
- 記住告訴照片衝洗人員，有些照片為全景攝影。此種服務可能會有附加收費。

## 注意事項

- 使用此模式時可以印制日期。  
(僅限Q.D.式 - 參閱第 27頁)



<Normal>  
<正常模式>



<Panorama>  
<全景模式>

## CARE AND STORAGE/保養與保存

- En
- If your camera needs cleaning, wipe it with a soft, lintless cloth.
  - The lens should be cleaned only with special lens cleaning tissue and fluid.(Consult your camera retailer.)
  - Do not allow your camera to come into contact with sand or water.
  - Keep your camera in a dry, cool place that is free from high humidity and dust.
  - Never leave your camera in hot places such as a parked car, or direct sunlight.
  - Avoid sudden shocks or vibration. If you drop your camera, it is a good idea to have it checked before using it.

### Warning

- Do not try to disassemble the camera yourself.  
Your camera contains high voltage circuitry and may cause injury if interfered with.
  - The temperature range in which the camera operates is between 50 °C and -10 °C (122 °F~14 °F).
  - The camera performance may be impaired when used in very cold weather. If you plan to take pictures when the temperature is below 7 °C (45 °F), take care to keep your camera and battery warm between shots. If your camera becomes very cold, allow it to return to room temperature slowly by keeping it in its case. Condensation can spoil pictures and in extreme conditions can damage the electronic components inside the camera.
- ※ If you have trouble with your camera, please return it to your retailer for advice.

- 
- 中**
- 如果像機需要清潔，請用不起毛的軟布小心擦拭。
  - 只能使用專門的鏡頭紙及清洗液清洗鏡頭。（請向像機經銷商諮詢。）
  - 請避免在多沙或有水氣的地方使用像機。
  - 將像機保存在通風乾燥處，以防止潮濕及灰塵。
  - 不可將像機留置在高熱的地方，如太陽直接照射的地方或車上。
- 避免猛烈衝擊或震動。如果像機掉落地上，請在使用前先檢查一下。

### 警告

- 請勿自行將像機阿開。像機內有高壓線路，若藩到會造成損傷。
- 像機只適合在攝氏50度及零下10度之間操作。
- 在蜈冷的天氣下使用時，像機的性能會受到影響。如果要在攝氏7度以下拍照，請注意保暖的像機及電池。若像機的溫度蜈低，可將其留在像機套內，讓溫度緩慢回升到室溫。結露會損壞照片，并在極端情況下損壞像機內的電子元件。

※ 如果像機出現問題，請拿回給經銷商檢修。

## TROUBLE SHOOTING / 故障排除

**En** • If the shutter does not operate after pressing the shutter button.

**中** • 如果按下快門後快門不動作。

Check point / 檢查點	Remedy / 故障排除方法	Page / 參考頁數
Is the lens cover completely open? 鏡頭蓋是否完全打開?	Press the Power button again. 再按一下電源開關。	18
Is the battery loaded correctly? 電池是否正確安裝?	Reinsert correctly. 重新正確裝入。	13
Has it been a long time since you used the camera? 像機是否已經使用很久了?	Change the battery. 更換電池。	15

**En** • If a picture is partially dark or out of focus.

**中** • 如果照片部分黑暗或對焦不清。

Check point / 檢查點	Remedy / 故障排除方法	Page / 參考頁數
Was the lens or other sensors obstructed by your fingers or hair? 手指或頭髮是否遮住了鏡頭或其他感應器?	Be careful not to block the lens or the exposure sensor. 小心不要遮住鏡頭或曝光感應器。	19
Did you compose a subject correctly referring to the picture area frame? 主體是否正確地對準在自動對焦畫面?	Read the "Viewfinder and Indicators" 參閱 "觀景窗及指示燈"	11,12
Did you set the camera to the panorama mode? 是否將像機設置在全景模式中?	Release the panorama mode. 釋放全景模式。	53



# SPECIFICATIONS/ 技術規格

<b>En</b>	<b>TYPE</b>	35mm fully automatic lens shutter camera.
<b>FILM</b>	<b>Format</b>	35mm DX-coded film, 24x36mm
	<b>Speed</b>	Automatic setting with DX-coded film, ISO 50~3200
	<b>Loading</b>	Automatic advance to the first frame when the back cover is closed.
	<b>Winding</b>	Automatic advance, Single or Continuous shooting
	<b>Rewinding</b>	Automatic rewinding, Mid-roll rewinding
<b>LENS</b>		Schneider lens F4.5 ~ 11.0 / 28 -90mm 9 elements 8 groups
<b>SHUTTER</b>		Programmed AE electronic focusing Shutter speed : 1/3 ~ 1/400 sec. Bulb mode(B shutter) : 60 ~ 1 sec.
<b>EXPOSURE</b>		Programmed auto exposure AE coupling range (ISO 100 film) · WIDE(28mm) : EV 6.0 ~ 17 · TELE(90mm) : EV 8.4 ~ 17
<b>VIEWFINDER</b>		Real image type with autofocus frame Field of view : 80% Magnification : 0.32 ~ 0.9 Close range picture area mark Connection with Panorama switch

<b>FLASH</b>	<b>Type</b>	Built-in electronic flash			
	<b>Range</b>	ISO	100	200	400
		28mm(WIDE)	5.3m / 17.4ft	7.4m / 24.3ft	10.5m / 34.4ft
90mm(TELE)		2.4m / 7.9ft	3.4m / 11.2ft	4.7m / 15.4ft	
	<b>Recycling time</b>	Approx. 6~8 sec.			
<b>SPECIAL FEATURES</b>	<b>Shooting mode</b>	· SPOT shooting · PORTRAIT zoom · CONTINUOUS shooting · Step zoom · LANDSCAPE shooting ; WIDE(28mm):3.5m~∞(11.5ft~∞), TELE(90mm):14m~∞(45.9ft~∞) · Bulb shooting(B Shutter) · SNAP shooting(between 1.5 ~ 7m (4.9 ~ 22.9ft))			
	<b>Flash mode</b>	· Auto red-eye reduction · Auto flash · Fill-in flash · Fill-in flash & Red-eye reduction · Flash off			
	<b>Autofocus mode</b>	· Passive multi autofocus			
	<b>Self mode</b>	· Single/Double self-timer · 2 sec. delayed shutter release · Remote control(Optional)			
		· Panorama mode (Switchable)			
<b>DATE AND CAPTION (Q.D.model only)</b>		Date or Time setting - 5 different formats (The camera will set the date automatically until 2099.) Captions imprint-7 different messages			
<b>POWER SOURCE</b>		One 3V lithium battery (CR 123A)			
<b>DIMENSIONS(WxHxD)</b>		116.5 x 65.5 x 43mm / 4.57 x 2.57 x 1.69in			
<b>WEIGHT</b>		250g / 8.8oz (without battery)			

- Specifications are subject to change without prior notice.
- All data are based on SAMSUNG'S standard test methods.

型式	35mm 全自動像機.	
底片	規格	35mm DX 底片, 24x36mm
	感光度	自動設定 DX 值, ISO 50~3200
	裝片	背蓋關上後, 自動前進至第一張.
	進片	自動前進至下一張, 單拍或連續拍攝模式
	退片	自動退片, 中途退片
鏡頭	Schneider lens F4.5~11.0 / 28-90mm 9片8組	
快門	電子程序式快門 快門速度: 1/3 ~ 1/400 秒 B快門: 60 ~ 1 秒	
曝光值	程序式自動曝光系統 自動曝光範圍 (ISO 100 底片) · 廣角 (28mm): EV 6.0 ~ 17 · 望遠 (90mm): EV 8.4 ~ 17	
觀景窓	帶自動對焦 的實像型 視野: 80% 放大倍數: 0.32~0.9 微距取景 與全景開關相連	

閃光燈	型式	內藏式電子閃光燈			
	範圍	ISO	100	200	400
		28mm(WIDE)	5.3m / 17.4ft	7.4m / 24.3ft	10.5m / 34.4ft
		90mm(TELE)	2.4m / 7.9ft	3.4m / 11.2ft	4.7m / 15.4ft
回電時間	大約 6~8 秒鐘.				
特殊性能	拍攝模式	· 選點 拍攝模式 · 連續拍攝模式 · 遠景模式;廣角(28mm):3.5m ~ [∞](11.5ft~[∞]), 望遠(90mm)14m ~ [∞](45.9ft~[∞]) · B 快門 · 快拍模式(1.5~7.0m(4.9~22.9ft)) · 變階式變焦模式 · 自動取景模式			
	閃光燈 模式	· 自動消除紅眼 · 自動閃光 · 不用閃光燈 · 閃光燈強迫補光 · 閃光燈強迫補光及消除紅眼			
	自動對焦模式	· 被動多束自動對焦			
	自拍模式	· 單次/兩次自拍 · 兩秒鐘延遲拍攝 · 遙控(可選)			
	· 全景攝影				
日期及留言 (僅限Q.D.式)	日期或時間設置 - 5種不同格式 (2099年之前像「會自動設定日期.」) 留言印制 7 種不同的留言				
電源	一個3V 裏電池(CR 123A)				
體積(WxHxD)	116.5 x 65.5 x 43mm / 4.57 x 2.57 x 1.69in				
重量	250g / 8.8oz (不含電池)				

- 規格如有變動,恕不另行通知。
- 以上資料是由SAMSUNG 公司的標準測試原則為基準。

# CHECKING THE CAMERA

---

## ●Checking the shutter condition

- You can check the condition of the shutter by pressing it.  
The short “click” sound will result.

## ●Checking the irises

- After removing the back cover of a camera, it is normal to see the closed lens opening up when you press the shutter.
- The irises will adjust depending on the light condition.

Dark light will cause them to open wide; bright light will cause the narrowing of the irises.

- If the irises were opened before pressing the shutter or cannot be opened, the irises are not operating properly.

## ●Film transferring device

- It is normal to hear the motor running after you open and close the camera cover.
- It is normal to hear the motor running after you press the Mid-roll rewinding button.
- After examining the Mid-roll rewinding condition, set the camera to the default state and check other functions.

## ●Flash Activation

- Check the Auto Flash Mode indoors.

※ It is important to check your camera prior to up-coming event to prevent possible psychological and monetary damage once the camera is not working properly at the day of the event.

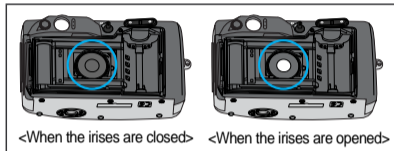

## 檢查照相機

### ●檢查快門的狀態

—按快門“能求檢查他的狀態如何，會發生一短一短的聲音。

### ●檢查膜片

—脫掉照相機的後蓋之後，按快門時鏡頭向上開的是正常的狀態。

—膜片的大小在光線的狀態來決定。不亮的狀態下膜片為大起來。光亮的狀態下膜片為縮小。

—按快門“之前膜片開始動作，這可能在膜片發生問題。相反地，按了也沒有任何動作，這也發生問題的。

### ●替換膠卷裝備

—把照相機後蓋脫掉或者穿上時聽到電動機的聲音，這是正常的。

—按中途退片“時聽到電動機的聲音，這也是正常的。

—檢查中途退片“的狀態之後，把照相機設定為開始模式，然後檢查其他功能

### ●閃光燈的作動

—在室內檢查自動閃光燈模式。

※ 到了某些活動日子照相機發生了問題，會太麻煩，可能心理上或者經濟上有損失，所以提前檢查他的狀態是重要的。

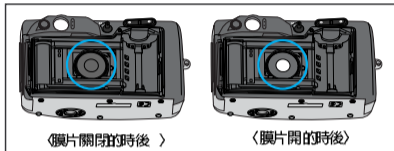

# MEMO

---

-----

-----

-----

-----

-----

-----

-----

-----

-----

-----

-----

-----

-----

-----

The Samsung logo, consisting of the word "SAMSUNG" in white, bold, sans-serif capital letters, centered within a blue, horizontally-oriented oval.

SAMSUNG TECHWIN CO., LTD.  
OPTICS & DIGITAL IMAGING DIVISION  
145-3, SANGDAEWON 1-DONG, JUNGWON-  
GU, SUNGNAM-CITY, KYUNGKI-DO, KOREA 462-121  
TEL : (82) 31-740-8086, 8088, 8090, 8092, 8099  
FAX : (82) 31-740-8398, 8399

SAMSUNG OPTO-ELECTRONICS AMERICA, INC.  
HEADQUARTERS  
40 SEAVIEW DRIVE, SECAUCUS, NJ07094  
TEL : (1) 201-902-0347  
FAX : (1) 201-902-9342  
WESTERN REGIONAL OFFICE  
18600 BROADWICK ST.,  
RANCHO DOMINGUEZ, CA 90220  
TEL : (1) 310-537-7000  
FAX : (1) 310-537-1566

SAMSUNG U.K. LIMITED.  
PHOTO PRODUCTS DIV.  
SAMSUNG HOUSE, 3 RIVERBANK WAY,  
GREAT WEST ROAD, BRENTFORD,  
MIDDLESEX, TW8 9RE, U.K.  
TEL : (44) 20-8232-3348  
FAX : (44) 20-8569-8385

SAMSUNG DEUTSCHLAND GmbH  
SAMSUNG HAUS  
AM KRONBERGER HANG 6, 65824 SCHWALBACH,  
GERMANY  
TEL : (49) 6196-66 53 01  
FAX : (49) 6196-66 53 33

SAMSUNG FRANCE S.A.R.L.  
BP 51 TOUR MAINE MONTPARNASSE 33,  
AV. DU MAINE 75755,  
PARIS CEDEX 15, FRANCE  
TEL : (33) 1-4279-2282  
FAX : (33) 1-4320-4510

SAMSUNG TECHWIN MOSCOW OFFICE  
KOSMODAMIANSKAYA NABEREZNA 40/42,  
MOSCOW, 113035, RUSSIA  
TEL : (7) 095-937-7950  
FAX : (7) 095-937-4851

SAMSUNG (Aust.) PTY. LTD.  
LEVEL 33, NORTHPOINT BLDG., 100 MILLER STREET,  
NORTH SYDNEY,  
NSW 2060, AUSTRALIA  
TEL : (61) 2-9955-3888  
FAX : (61) 2-9955-4233

TIANJIN SAMSUNG OPTO-ELECTRONICS CO.,LTD.  
7 PINGCHANG ROAD NANKAI DIST., TIANJIN  
P.R CHINA  
POST CODE:300190  
TEL : (86) 22-2761-8867  
FAX : (86) 22-2761-8864

\* Internet address - <http://www.samsungcamera.com/>



The CE Mark is a Directive conformity  
mark of the European Community (EC)

6806 -1215